

**RICHMOND MUNICIPAL AIRPORT
RICHMOND, INDIANA
SNOW REMOVAL EQUIPMENT BUILDING
FEDERAL AVIATION ADMINISTRATION
AIP No. 3-18-0071-028-2024**

CONTRACT DOCUMENTS AND SPECIFICATIONS

**RICHMOND BOARD OF
AVIATION COMMISSIONERS**

**RICHMOND MUNICIPAL AIRPORT
RICHMOND, INDIANA**

SNOW REMOVAL EQUIPMENT BUILDING

JANUARY 15, 2024

**BUTLER, FAIRMAN and SEUFERT, INC.
8450 Westfield Boulevard, Suite 300
INDIANAPOLIS, INDIANA 46240-5920**

CERTIFIED BY:

Zachary R. Weber

DATE: January 15, 2024

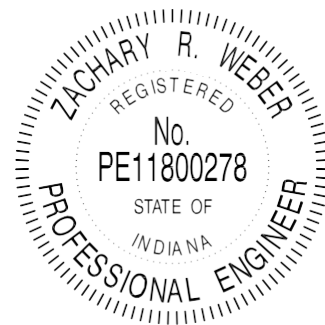

TABLE OF CONTENTS

<u>SECTION</u>	<u>PAGE</u>
ADVERTISEMENT FOR BIDS.....	AB-1
INSTRUCTION TO BIDDERS.....	IB-1
PROPOSAL	IP-1
NOTICE OF AWARD	NOA-1
CONSTRUCTION CONTRACT	C-1
CORPORATE RESOLUTION.....	CR-1
PERFORMANCE BOND.....	PRB-1
PAYMENT BOND	PYB-1
AC 150/5370-2G SAFETY PLAN COMPLIANCE DOCUMENT (SPCD).....	SPCD-1
NOTICE TO PROCEED.....	NTP-1
CONTRACT REQUIREMENTS FOR FEDERAL AID PROJECTS.....	FP-1
WAGE RATES.....	WR-1
PART 1 – GENERAL CONTRACT PROVISIONS	
Section 10 Definition of Terms	
Section 20 Proposal Requirements and Conditions	
Section 30 Award and Execution of Contract	
Section 40 Scope of Work	
Section 50 Control of Work	
Section 60 Control of Materials	
Section 70 Legal Regulations and Responsibility to Public	
Section 80 Execution and Progress	
Section 90 Measurement and Payment	
PART 2 – TECHNICAL SPECIFICATIONS	
Section 1 – General	
Section 2 – Sitework	
Section 3 – Not Applicable	
Section 4 – Not Applicable	
Section 5 – Concrete Work	
Section 6 – Not Applicable	
Section 7 – Pre-Engineered Metal Building	
Section 8 – Insulation	
Section 9 – Doors and Windows	
Section 10 – Not Applicable	
Section 11 – Plumbing	
Section 12 – Heating and Ventilation	

Section 13 – Electrical
Section 14 – Not Applicable
Section 15 – Post Frame Building

SPECIAL PROVISIONS..... SP-1

ADVERTISEMENT FOR BIDS
SNOW REMOVAL EQUIPMENT BUILDING
RICHMOND MUNICIPAL AIRPORT
RICHMOND, INDIANA

Sealed proposals will be received by the Richmond Board of Aviation Commissioners, "Owner", at the Richmond Municipal Airport Terminal Building, Richmond Municipal Airport, 5169 State Road 227, Richmond, IN 47374, until **2:00 p.m.** (local time), on March 14th, 2024, and then will be publicly opened and read aloud at the Richmond Board of Aviation Commissioners Meeting which begins at 5:00 p.m. at 50 N 5th St., Richmond, IN 47374. Any bids received later than 2:00 p.m. will be returned unopened.

DESCRIPTION OF WORK: Work for which proposals are to be received is for the design build of a pre-engineered timber frame 40'x50' snow removal equipment building, new concrete apron, grading, building and framework, electrical, mechanical, utility services, erosion control, and necessary incidentals to complete the work as detailed on the Contract Drawings and specified in the Contract Documents titled Snow Removal Equipment Building, which is considered a 30% conceptual design. The contractor shall provide all labor, equipment, and material necessary to complete the work. All work is located at the Richmond Municipal Airport, 5169 State Road 227, Richmond, IN 47374.

BID DOCUMENTS: Copies of the Specifications and Contract Documents may be obtained at the office of Butler, Fairman, and Seufert, Inc., 8450 Westfield Blvd., Suite 300, Indianapolis, IN 46240, call 317-713-4615 or email LHalloran@BFSEngr.com. Copies of the documents are available for examining at the Richmond Municipal Airport, BXIndiana Construction League, 1028 Shelby Street, Indianapolis, Indiana; and the online planrooms of Dodge Data and Analytics, ISQFT/ConstructConnect™, BidTool and at the office of Butler, Fairman, and Seufert, Inc., 8450 Westfield Blvd., Suite 300, Indianapolis, IN 46240.

Copies of the bid documents will be made available through one of the following methods:

- as digital files made available to the planholder for download at no cost
- as hard copies picked up at the office of the Engineer upon remittance of \$125

This remittance is not refundable. Payment shall be by money order or check and shall be made payable to Butler, Fairman, and Seufert, Inc. Bidders are required to be a plan holder of record having obtained the contract documents through the office of the Engineer. **Bids not meeting this requirement will be deemed non-responsive.**

Bids shall be properly executed and addressed to the address shown above where bids are to be received together with the documents required by the bid forms, specifications, and related legal documents contained in the Contract Documents.

No Bidder may withdraw his proposal within a period of one hundred and twenty (120) days following the date set for the receiving of bids. The Owner reserves the right to retain any and all bids for a period of not more than one hundred and twenty (120) days and said bid shall remain in

full force and effect during said time. The Owner further reserves the right to waive informalities and to award the Contract to any Bidder all to the advantage of the Owner or to reject all bids.

BID SECURITY: A bid bond with good and sufficient surety issued by a company licensed to do business in the State of Indiana or a certified check on a solvent bank equal to five percent (5%) of the total bid insuring that if the bid is accepted, a contract will be entered into and the performance of its proposal secured.

BONDS: A Performance Bond and Payment Bond each in the amount of 100 percent of the Contract price will be required.

FEDERAL REQUIREMENTS: The Owner, in accordance with Title VI of the Civil Rights Act of 1964, 78 Stat. 252, 42 U.S.C. 2000d to 2000d-4, and Title 49, Code of Federal Regulations, Department of Transportation, Subtitle A, Office of the Secretary, Part 21, Nondiscrimination in Federally-assisted programs of the Department of Transportation issued pursuant to such Act, hereby notifies all bidders that it will affirmatively insure that in any contract entered into pursuant to this advertisement, Disadvantaged Business Enterprises will be afforded full opportunity to submit bids in response to this invitation and will not be discriminated against on the grounds of race, color, sex, or national origin in consideration for an award.

1. The proposed contract is under and subject to Executive Order No. 11246 of September 24, 1965, equal opportunity clause, and to Title VI of the Civil Rights Act of 1964.
2. The Bidder must supply all the information required by the bid or proposal form.

INDIANA REQUIREMENTS: Each bid shall be accompanied by bidder's financial statement, a statement of experience, a proposed plan or plans for performing the public work, and the equipment that bidder has available for the performance of the public work. Such statements shall be submitted on forms prescribed by the State Board of Accounts, including Bid Forms 96, together with the required non-collusion affidavit.

A pre-bid conference will be held in the Terminal Building at the Richmond Municipal Airport on February 28, 2024, at 10:00 a.m.

The Owner reserves the right to reject any and/or all bids and to waive any formalities in the bidding procedure.

RICHMOND BOARD OF AVIATION COMMISSIONERS, RICHMOND, IN
Jonathan Meade, President

INSTRUCTIONS TO BIDDERS

Sealed Proposals and Public Opening: The Richmond Board of Aviation Commissioners (the "Owner"), will receive sealed bids for the Snow Removal Equipment Building project which will include the design build of a pre-engineered timber frame 40'x50' snow removal equipment building, new concrete apron, grading, building and framework, electrical, mechanical, utility services, erosion control, and necessary incidentals to complete the work as detailed on the Contract Drawings and specified in the Contract Documents titled Snow Removal Equipment Building prepared by the Engineer, Butler, Fairman and Seufert, Inc., at the time and place set forth in the Advertisement for Bids.

Bids shall be properly executed, addressed to the Owner on Form 96 with Itemized Proposal Form, accompanied by a financial statement giving financial data as recent as possible, a non-collusion affidavit, and a bond or certified check on a solvent bank equal to five percent (5%) of the total bid insuring that if the bid is accepted a contract will be entered into and the performance of its proposal secured and Letters of Intent for each subcontractor.

Proposals shall not contain any recapitulations of the work to be done. Alternate proposals will not be considered in the Itemized Proposal, except where shown as an optional alternate by the Engineer. Oral proposals or modifications will not be considered.

All items of information included in the Itemized Proposal form must be completed. Failure to do so shall be cause for rejection of the bid proposal. The Bidder as a minimum must submit a completed pricing proposal for all bid quantities and totals.

The bidder may submit letter size computer produced Itemized Proposal Sheets in lieu of filling in the Itemized Proposal Sheets furnished in the Bid Proposal Package. The computer produced sheets will clearly show the Project name on each page and contain headings and items identical to, and in the same order as, those on the Proposal Sheets furnished. If the computer produced Itemized Proposal Sheets, when compared to the sheets furnished, contain errors, omissions or additions, the Itemized Proposal Sheets as furnished shall govern and the bid may be rejected as specified in the General Provisions section titled "Irregular Proposals."

Before submitting a proposal, bidders shall carefully examine the drawings, read the specifications and other Contract Documents, shall visit the site of work, and shall fully inform themselves as to all existing conditions and limitations, and shall include in the proposal a sum to cover the cost of all items included in the contract documents. Visitation of the site will be made only through the Owners Office; Telephone: (765) 983-7296.

Proposals shall be delivered by the time and to the place stipulated in the Advertisement. It is the sole responsibility of the bidder to see that his proposal is received in the proper time. Any proposal received after the scheduled closing time for receipt of proposals shall be returned to the bidder unopened.

Any bidder may withdraw his proposal, by written request, at any time prior to the scheduled closing time for receipt of proposals.

Proposals will be opened and publicly read aloud at the time and place set forth in the Advertisement.

One of the criteria for the selection of the successful bidder may be the lowest bid of one or any combination of the bid amounts submitted.

Award or Rejections: The Contract will be awarded to the lowest responsible and responsive bidder complying with the conditions for bidding, provided the bid is reasonable and is to the best interest of the Owner to accept it. The Owner reserves the right to reject the bid of any bidder who has previously failed to perform properly or complete on time, contracts of a similar nature, who is not in a position to perform the contract, or who has habitually and without just cause neglected the payment of bills or otherwise disregarded obligations to subcontractors, materialmen, or employees. In determining the lowest responsible and responsive bidder in the best interest of the Owner, the following elements in addition to those above mentioned will be considered: whether the bidder involved (a) maintains a permanent place of business; (b) has adequate plant equipment to do the work properly and expeditiously; (c) has a suitable financial status to meet the obligations incident to the work; (d) has appropriate technical experience; and (e) has listed competent, responsible, and qualified subcontractors, material, suppliers, or vendors.

A contract shall be deemed as having been unconditionally awarded when formal notice of award shall have been duly served upon the intended awardee (i.e., the bidder to whom the Owner intends awarding the Contract) by some officer or agent of the respective Owner duly authorized to give such notice.

The bidder is advised that the contractor will be required to perform, with his own personnel and forces, a minimum of forty percent (40%) of the work.

The Owner is under no obligation to accept the lowest or any other bid, and expressly reserves the right to accept or reject any and/or all bids, and to waive to the extent permitted by law any of the terms, conditions and provisions contained in the Advertisement for Bids or other documents, or any informality, irregularity, or omission in any bid and make any combination of bids provided that such waiver shall, in the discretion of the Owner, be to its advantage and in its best interest.

No bidder may withdraw his proposal for a period of sixty (60) days after the bid date.

Interpretation of Documents: If any person contemplating submitting a proposal is in doubt as to the true meaning of any part of the drawings, specifications, or other Contract Documents, or finds discrepancies in or omissions from the drawings or specifications, he may submit to the Engineer a written request for interpretation or correction thereof. The person submitting the request will be responsible for its prompt delivery. Any interpretation or correction of the Documents will be made only by addendum duly issued and a copy of the addendum will be mailed or delivered to each person receiving a set of Contract Documents. Neither the Owner nor the Engineer will be responsible for any other explanations or interpretations of the contract documents.

Addenda: Any addenda issued during the time of bidding or forming a part of the Contract Documents issued to the bidder for the preparation of his proposal, shall be covered in the proposal, and shall be made a part of the Contract. Receipt of each addendum shall be acknowledged in the proposal.

Bidders interested in more than one Proposal: No person, firm, or corporation shall be allowed to make, file, or to be interested in more than one proposal for the same work, unless alternate proposals are requested. A person, firm, or corporation who has submitted a subproposal to a bidder, or who has quoted prices on materials to a bidder, is not hereby disqualified from submitting a subproposal or quoting prices to other bidders.

Proposal and Performance Guarantee: Each bid shall contain the full name of every person or company interested in it and shall be accompanied by a bond or certified check on a solvent bank equal to Five percent (5%) of the total bid insuring that if the bid is accepted a Contract will be entered into and the performance of its proposal secured. No bid will be accepted unless it is so guaranteed.

A performance and payment bond with good and sufficient surety, in the form set forth in the Contract, issued by a company licensed to do business in the State of Indiana, and approved by the Owner, shall be required of all contracts in an amount equal to at least one hundred percent (100%) of the contract price. A combination bid bond and performance bond in the sum included in the specifications will be acceptable if the above requirements are included. The guaranty period (as defined in the Offer and Contract) shall extend for a period of one (1) year from the date of substantial completion (as defined in the Construction Contract) of the Project. The proposal guarantees of all bidders, except the two lowest responsible and responsive bidders, will be returned promptly after the canvass of proposals.

In the event the bidder withdraws the bid or fails to execute a satisfactory Construction Contract and furnish a satisfactory performance and payment bond with a surety company in accordance with Section 30-05 of the General Provisions, for 100% of the contract amount within seven (7) days after a contract has been unconditionally awarded to such a bidder by the Owner, the Owner may declare such certified or cashier's check or bid bond forfeited to the Owner for extra costs incurred by reason of delay of the project and obtaining acceptable prices from another bidder.

Wage Scale: The Contractor shall conform to the prescribed scale of wages as determined in accordance with the most recent Wage Rate Decision of the Secretary of the U.S. Department of Labor; all acts amendatory thereof and supplemental thereto currently in effect 7 days prior to bid opening date as prepared by the U.S. Department of Labor.

Bid Proposal: The unit prices submitted shall become the basis for partial payments of work performed and for additional or deductible items of work, other than required by the plans and/or specifications. The quantities of work to be performed as shown on the proposal shall be considered as a basis of bidding and as a guide only. Partial payments for all work performed by the Contractor, as required by the Contract Documents, shall be based on the estimated quantities as determined by the Engineer. Final payment for the work required by the Contract Documents, and/or modified by change orders, shall be based on the measured actual quantities as determined by the Engineer.

Completion of Time: All work under this contract shall be substantially completed according to the terms of the entire contract within the time and conditions specified from the date established in the Notice to Proceed. See General Provisions subsection 80-08 FAILURE TO COMPLETE ON TIME.

Notice to Proceed: No work shall commence until the Owner issues a written Notice to Proceed with the construction work under this contract.

The successful bidder and his proposed subcontractors will be required to submit evidence of his compliance with the requirements of the President's Committee on Equal Employment Opportunity, and such other pertinent information regarding his own employment policies and practices as well as those of his proposed subcontractors, as the FAA, the Owner, or the Office

of Federal Contract Compliance in the United States Department of Labor may require, prior to award of the Contract.

Where identified, separate and independent Notice to Proceeds will be issued for each division, phase, or sequence of work.

Disadvantaged Business Enterprise Plan: The solicitations for DOT-assisted contracts for which a contract goal has been established will include the following:

It is encouraged to the greatest extent feasible the use of the services offered by institutions owned and controlled by socially and economically disadvantaged individuals. Information on known institutions may be obtained from the Airport Manager.

The contractor, sub recipient or subcontractor shall not discriminate on the basis of race, color, national origin, or sex in the performance of this contract. The contractor shall carry out applicable requirements of 49 CFR part 26 in the award and administration of DOT-assisted contracts. Failure by the contractor to carry out these requirements is a material breach of this contract, which may result in the termination of this contract or such other remedy as the recipient deems appropriate.

The bidder/offeror shall make good faith efforts, as defined in Appendix A of 49 CFR part 26, Regulations of the Office of the Secretary of Transportation, to subcontract **See Proposal** percent of the dollar value of the prime contract to small business concerns owned and controlled by socially and economically disadvantaged individuals (DBE).

- (1) Award of the contract will be conditioned on meeting the contract goal or good faith effort requirements.
- (2) The bidder/offeror shall include with their bid proposal the following information:
 - (i) The names and addresses of DBE firms that will participate in the contract;
 - (ii) A description of the work that each DBE will perform;
 - (iii) The dollar amount of the participation of each DBE firm participating and calculated percentage of the contract amount;
 - (iv) Written documentation of the bidder/offeror's commitment to use a DBE subcontractor whose participation it submits to meet a contract goal;
 - (v) Written confirmation from the DBE that it is participating in the contract as provided in the prime contractor's commitment; and
 - (vi) If the contract goal is not met, the bidder/offeror assures that evidence of good faith efforts will be submitted within 5 working days after bid submittal and prior to award of contract:(see Appendix A of this part).
- (3) Evidence of the bidder/offeror's good faith effort shall include documentation of the following types of actions:
 - (i) Soliciting through all reasonable and available means (e.g. attendance at prebid meetings, advertising and/or written notices) the interest of all certified DBEs who have the capability to perform the work of the contract. The bidder must solicit this interest within sufficient time to allow the DBEs to respond to the solicitation. The bidder must determine with certainty if the DBEs are interested by taking appropriate steps to follow up initial solicitations.
 - (ii) Selecting portions of the work to be performed by DBEs in order to increase the likelihood that the DBE goals will be achieved. This includes, where appropriate, breaking out contract work items into economically feasible units to facilitate DBE participation, even when the prime contractor might otherwise prefer to perform these work items with its own forces.

(iii) Providing interested DBEs with adequate information about the plans, specifications, and requirements of the contract in a timely manner to assist them in responding to a solicitation.

(iv) Negotiating in good faith with interested DBEs.

(a) It is the bidder's responsibility to make a portion of the work available to DBE subcontractors and suppliers and to select those portions of the work or material needs consistent with the available DBE subcontractors and suppliers, so as to facilitate DBE participation. Evidence of such negotiation includes the names, addresses, and telephone numbers of DBEs that were considered; a description of the information provided regarding the plans and specifications for the work selected for subcontracting; and evidence as to why additional agreements could not be reached for DBEs to perform the work.

(b) A bidder using good business judgment would consider a number of factors in negotiating with subcontractors, including DBE subcontractors, and would take a firm's price and capabilities as well as contract goals into consideration. However, the fact that there may be some additional costs involved in finding and using DBEs is not in itself sufficient reason for a bidder's failure to meet the contract DBE goal, as long as such costs are reasonable. Also, the ability or desire of a prime contractor to perform the work of a contract with its own organization does not relieve the bidder of the responsibility to make good faith efforts. Prime contractors are not, however, required to accept higher quotes from DBEs if the price difference is excessive or unreasonable.

(v) Not rejecting DBEs as being unqualified without sound reasons based on a thorough investigation of their capabilities. The contractor's standing within its industry, membership in specific groups, organizations, or associations and political or social affiliations (for example union vs. non-union employee status) are not legitimate causes for the rejection or non-solicitation of bids in the contractor's efforts to meet the project goal.

(vi) Making efforts to assist interested DBEs in obtaining bonding, lines of credit, or insurance as required by the recipient or contractor. (vii) Making efforts to assist interested DBEs in obtaining necessary equipment, supplies, materials, or related assistance or services.

(viii) Effectively using the services of available minority/women community organizations; minority/women contractors' groups; local, state, and federal minority/women business assistance offices; and other organizations as allowed on a case-by-case basis to provide assistance in the recruitment and placement of DBEs.

(4) In determining whether a bidder has made good faith efforts, you may take into account the performance of other bidders in meeting the contract. For example, when the apparent successful bidder fails to meet the contract goal, but others meet it, you may reasonably raise the question of whether, with additional reasonable efforts, the apparent successful bidder could have met the goal. If the apparent successful bidder fails to meet the goal, but meets or exceeds the average DBE participation obtained by other bidders, you may view this, in conjunction with other factors, as evidence of the apparent successful bidder having made good faith efforts.

(5) All information shall be reviewed for completeness and accuracy and that it adequately documents the bidder/offeror's good faith efforts before award to the performance of the contract by the bidder/offeror is made.

(6) Failure to carry out the requirement by the prime contractor is grounds for breach of contract, which may result in the termination of this contract or other applicable enforcement action under 49 CFR Part 26, especially Sections 26.101 through 26.109. Any person who makes a false or fraudulent statement in connection with participation of a DBE in any DOT-assisted program or otherwise violates applicable federal statutes will be referred to the Department of Justice for prosecution under 18 U.S.C. 1001 or other applicable provisions of law.”

In accordance with the FAA Mentor-Protégé Program found in web site: <http://www.sbo.faa.gov/MentorProtege.cfm>, all screening information requests and contracts with subcontracting plans or in the case of small business set-asides exceeding \$650,000 (\$1,500,000 for construction) that offer subcontracting opportunities the following shall apply:

FAA Mentor-Protégé Program

- a. Large and small businesses are encouraged to participate in the FAA Mentor-Protégé Program for the purpose of providing developmental assistance to eligible protégé entities to enhance their capabilities and increase their participation in FAA contracts.
- b. The program consists of:
 - o Mentor firms, which are large prime contractors or eligible small businesses capable of providing developmental assistance;
 - o Protégé firms, which include small businesses preferably socially and economically disadvantaged businesses, small disadvantaged businesses, historically black colleges and universities, minority educational institutions, service-disabled veteran-owned small businesses and woman-owned small businesses; and
 - o Mentor-Protégé Agreements, approved by the FAA Team (SBDPG, Integrated Product Team/Product Team).
- c. Mentor participation in the program means providing technical, managerial, and financing assistance to aid protégés in developing requisite high-tech expertise and business systems to compete for and successfully perform FAA contracts and subcontracts.
- d. Contractors interested in participating in the program are encouraged to contact the FAA SBDPG, (310) 725-7563, for further information.

15000 Aviation Blvd, Room 5018A

Lawndale, CA 90260

Attn: Alice C. Harris, Management/Program Analyst, Small Business Development Program Group, (ACQ-021)

Evaluation of Prime Contractor participation in the FAA Mentor-Protégé Program. FAA will evaluate the proposed participation and extent of developmental assistance to be provided by mentor firms to protégé firms as an approved mentor firm in the FAA Mentor-Protégé Program.

Mentor Requirements and Evaluation

- a. The purpose of the FAA Mentor-Protégé Program is for FAA Mentors to provide developmental assistance to qualifying protégés. Eligible protégés include small businesses preferably Historically Black Colleges and Universities, small disadvantaged businesses, Minority Institutions, Service-Disabled Veteran-Owned Small Businesses, Small Socially and Economically Disadvantaged Business concerns including women owned small businesses, as those terms are defined herein.
- b. FAA will evaluate the contractor's performance through the Performance Evaluation process. The evaluation will consider the following:
- o Specific actions taken by the contractor, during the evaluation period, to increase the participation of protégés as suppliers to the Federal Government;
 - o Specific actions taken by the contractor, during the evaluation period, to develop the technical and corporate administrative expertise of a protégé as defined in the agreement;
 - o To what extent the protégé has met the developmental objectives in the agreement; and o To what extent the mentor firm's participation in the Mentor-Protégé Program resulted in the protégé receiving competitive contract(s) and subcontract(s) from private firms and agencies other than the FAA.
- c. Semi-annual reports shall be submitted by the mentor to the FAA Mentor-Protégé Program Manager (FAA SBDPG) to include information as outlined.
- d. The mentor shall notify the SBDPG and the Integrated Product Team/Product Team, in writing, at least 30 days in advance of the mentor firm's intent to voluntarily withdraw from the program or upon receipt of a protégé's notice to withdraw from the program.
- e. Mentor and protégé firms shall submit a "lessons learned" evaluation to the FAA SBDPG at the conclusion of their effort. At the conclusion of each year in the Mentor-Protégé program, the mentor and protégé, as appropriate, will formally brief the FAA Mentor- Protégé Program Manager, the technical program manager, and the contracting officer during the formal program review regarding program accomplishments as pertains to the approved agreement.

Insurance Requirements: Contractor shall provide a Certificate of Insurance, evidencing insurance coverage, in the minimum amounts required in Section 70-21 of the General Provisions, to Owner prior to the start of work on the project. The Certificate Holder shall be identified as the Owner and any assignee of the Owner, as identified in writing by the Owner, which assignee is hereinafter identified as "Assignee".

Indemnification: The Contractor is responsible to the Owner and the Assignee, for the safe conduct of construction operations, as specified in Section 70 of the General Provisions, and agrees to indemnify the Owner, the Engineer and the Assignee pursuant specifically to the provisions of Section 70-11 of the General Provisions.

The Contract: The documents comprising the Contract shall include the following:

1. Advertisement for Bids
2. Instructions to Bidders
3. Proposal

4. Contractor's Bid Form 96
5. Addenda
6. Bid Bond, Performance and Payment Bond
7. Labor Provisions
8. Wage Rates
9. Construction Plans
10. General Provisions
11. Technical Provisions
12. Special Provisions
13. The Construction Contract Agreement Between the Parties
14. List of Subcontractors and Suppliers
15. Certificate of Insurance

The Contractor shall submit the following documents with the proposal:

1. Completed Proposal
2. Contractor's Bid Form 96
3. A 5% Bid Bond or a Certified Check
4. Letter of Intent for all Subcontractors and Suppliers

END OF INSTRUCTION TO BIDDERS

PROPOSAL

TO: Richmond Board of Aviation Commissioners
C/o Airport Manager
5169 South State Road 227
Richmond, IN 47374

The undersigned bidder, in compliance with the request for bids for construction of the following Project:

Snow Removal Equipment Building

submits this Proposal as a required supplement to the Contractor's Bid Form No. 96 upon which the bid is based. The undersigned further acknowledges that the undersigned is fully aware of all conditions existing regarding the Project and has full understanding of all work to be done as outlined in the plans and specifications for the Project; and further agrees that any change orders to the contract authorized by the Owner/Sponsor shall be based on the following schedule of unit prices where applicable.

The undersigned hereby proposes to furnish all labor, permits, material, machinery, tools, supplies, and equipment to faithfully perform all work required for construction of the Project in accordance with all Project documents and issued Addenda within the specified time of performance for the following prices:

RICHMOND MUNICIPAL AIRPORT					
ITEMIZED PROPOSAL					
SNOW REMOVAL EQUIPMENT BUILDING					
ITEM NO.	DESCRIPTION	UNIT	QUANTITY	UNIT PRICE	AMOUNT
General Site Work: Grading outside building limits and concrete apron					
S1	Mobilization/Demobilization	L.S.	1		
S2	Construction Engineering	L.S.	1		
S3	Unclassified Excavation	L.S.	1		
S4	Apron Concrete Pavement, 6 Inch	S.Y.	361		
S5	Crushed Stone Base, No. 53	C.Y.	65		
S6	Hydro Seeding	L.S.	1		
General Site Work TOTAL:					
Building: 40'x50' Snow Removal Equipment (SRE) Building					
B1	Pre-Engineered Timber Post Building (Includes the building delivered to the site)	L.S.	1		
B2	General Construction Work (Includes floor slab, foundations, building erection, and excavation for the building. It does not include any site work beyond the building walls)	L.S.	1		
B3	Electrical (Includes service connection, main panel, overhead lighting, outlets, door operator)	L.S.	1		
B4	Forced Air Heating and Ventilating, Stub Out and Concrete Pad for Future Propane Hookup	L.S.	1		
B5	40 Foot by 14 Foot Clear Opening One Piece Hydraulic Door	L.S.	1		
B6	Floor Trench Drain	L.F.	32		
Building TOTAL:					

ACKNOWLEDGEMENTS BY BIDDER

- a. By submittal of a proposal, the BIDDER acknowledges and accepts that the quantities established by the OWNER are an approximate estimate of the quantities required to fully complete the Project and that the estimated quantities are principally intended to serve as a basis for evaluation of bids. The BIDDER further acknowledges and accepts that payment under this contract will be made only for actual quantities and that quantities will vary in accordance with the General Provisions subsection entitled "Alteration of Work and Quantities".
- b. The BIDDER acknowledges and accepts that the Bid Documents are comprised of the documents identified within the Instructions to Bidders. The BIDDER further acknowledges that each of the individual documents that comprise the Bid Documents are complementary to one another and together establishes the complete terms, conditions and obligations of the successful BIDDER.
- c. As evidence of good faith in submitting this proposal, the undersigned encloses a bid guaranty in the form of a certified check or bid bond in the amount of 5% of the sum of all bid prices. The BIDDER acknowledges and accepts that refusal or failure to accept award and execute a contract within the terms and conditions established herein will result in forfeiture of the bid guaranty to the owner as a liquidated damage.
- d. The BIDDER acknowledges and accepts the OWNER'S right to reject any or all bids and to waive any minor informality in any Bid or solicitation procedure.
- e. The BIDDER acknowledges and accepts the OWNER'S right to hold all Proposals for purposes of review and evaluation and not issue a notice-of-award for the period specified in the bid documents from the stated date for receipt of bids.
- f. The undersigned agrees that upon written notice of award of contract, bidder will execute the contract within and provide executed payment and performance bonds the period specified in the bid documents from the date of contract execution. The undersigned accepts that failure to execute the contract and provide the required bonds within the stated timeframe shall result in forfeiture of the bid guaranty to the OWNER as a liquidated damage.
- g. Time of Performance: By submittal of this proposal, the undersigned acknowledges and agrees to commence work within the period specified in the bid documents of the date specified in the written "Notice-to-Proceed" as issued by the OWNER. The undersigned further agrees to complete the Project within the period specified in the bid documents from the commencement date specified in the Notice-to-Proceed.
- h. The undersigned acknowledges and accepts that for each and every Calendar/Working day the project remains incomplete beyond the contract time of performance, the Contractor shall pay the non-penal amount specified in the bid documents as a liquidated damage to the OWNER.
- i. The BIDDER acknowledges that the OWNER has established a contract Disadvantaged Business Enterprise goal specified in the bid documents for this project. The BIDDER acknowledges and accepts the requirement to apply and document good faith efforts, as defined in Appendix A, 49 CFR Part 26, for subcontracting a portion of the prime contract to certified Disadvantaged Business Enterprises (DBE), as defined in 49 CFR Part 26 for purposes of meeting the OWNER'S established goal. The BIDDER, in complying with this requirement, proposes participation by Disadvantaged Business Enterprises as stated on the attached forms, "Utilization Statement" and "Letter of Intent".
- j. The BIDDER accepts the requirement to pay prevailing wages for each classification and type of worker as established in the attached wage rate determination. The BIDDER further acknowledges and accepts their requirement to incorporate the provision to pay the established prevailing wages in every subcontract agreement entered into by the Bidder under this project.

k. Compliance Reports (41 CFR Part 60-1.7): Within 30 days after award of this contract, the Contractor/Subcontractor shall file a compliance report (Standard Form 100) if s/he has not submitted a complete compliance report within 12 months proceeding the date of award. This report is required if the Contractor/Subcontractor meets all of the following conditions:

1. Contractors/Subcontractors are not exempt based on 41 CFR 60 1,5.
2. Has 50 or more employees.
3. Is a prime contractor or first tier subcontractor.
4. There is a contract, subcontract, or purchase order amounting to \$50,000 or more.

The undersigned acknowledges receipt of the following addenda:

Addendum Number ___ dated _____ Received _____

Addendum Number ___ dated _____ Received _____

Addendum Number ___ dated _____ Received _____

REPRESENTATIONS BY BIDDER

By submittal of a proposal (bid), the BIDDER represents the following:

- a. The BIDDER has read and thoroughly examined the bid documents including all authorized addenda.
- b. The BIDDER has a complete understanding of the terms and conditions required for the satisfactory performance of project work.
- c. The BIDDER has fully informed themselves of the project site, the project site conditions and the surrounding area.
- d. The BIDDER has familiarized themselves of the requirements of working on an operating airport and understands the conditions that may in any manner affect cost, progress or performance of the work.
- e. The BIDDER has correlated their observations with that of the project documents.
- f. The BIDDER has found no errors, conflicts, ambiguities or omissions in the project documents, except as previously submitted in writing to the OWNER that would affect cost, progress or performance of the work.
- g. The BIDDER is familiar with all applicable Federal, State and local laws, rules and regulations pertaining to execution of the contract and the project work.
- h. The BIDDER has complied with all requirements of these instructions and the associated project documents.

CERTIFICATIONS BY BIDDER

- a. The undersigned hereby declares and certifies that the only parties interested in this proposal are named herein and that this proposal is made without collusion with any other person, firm or corporation. The undersigned further certifies that no member, officer or agent of OWNER'S has direct or indirect financial interest in this proposal.
- b. Certification of Non-Segregated Facilities: (41 CFR Part 60-1.8)
The BIDDER, as a potential federally-assisted construction contractor, certifies that it does not maintain or provide, for its employees, any segregated facilities at any of its establishments and that it does not permit its employees to perform their services at any location, under its control, where segregated facilities are maintained. The BIDDER certifies that it will not maintain or provide, for its employees, segregated facilities at any of its establishments and that it will not permit its employees to perform their services at any location under its control where segregated facilities are maintained. The Bidder agrees that a breach of this certification is a violation of the Equal Opportunity Clause, which is to be incorporated in the contract.
- c. As used in this certification, the term "segregated facilities" means any waiting rooms, work areas, restrooms, and washrooms, restaurants and other eating areas, timeclocks, locker rooms and other storage or dressing areas, parking lots, drinking fountains, recreation or entertainment areas, transportation, and housing facilities provided for employees which are segregated on the basis of race, color, religion, or national origin because of habit, local custom, or any other reason. The Bidder agrees that (except where it has obtained identical certifications from proposed subcontractors for specific time periods) it will obtain identical certifications from proposed subcontractors prior to the award of subcontracts exceeding \$10,000 which are not exempt from the provisions of the Equal Opportunity Clause and that it will retain such certifications in its files.
- d. Trade Restriction Certification: (49 CFR Part 30)
The Bidder, by submission of an offer certifies that it:
 1. is not owned or controlled by one or more citizens of a foreign country included in the list of countries that discriminate against U.S. firms published by the Office of the United States Trade Representative (USTR);

2. has not knowingly entered into any contract or subcontract for this project with a person that is a citizen or national of a foreign country on said list, or is owned or controlled directly or indirectly by one or more citizens or nationals of a foreign country on said list;
 3. has not procured any product nor subcontracted for the supply of any product for use on the project that is produced in a foreign country on said list.
- e. Certification Regarding Debarment, Suspension, Ineligibility and Voluntary Exclusion: (49 CFR Part 29)
The Bidder certifies, by submission of this proposal, that neither it nor its principals is presently debarred, suspended, proposed for debarment, declared ineligible, or voluntarily excluded from participation in this transaction by any Federal department or agency. It further agrees by submitting this proposal that it will include this clause without modification in all lower tier transactions, solicitations, proposals, contracts, and subcontracts. Where the Bidder or any lower tier participant is unable to certify to this statement, it shall attach an explanation to this solicitation/proposal.
- f. Buy American Certification: (Title 49 U.S.C. Chapter 501)
As a condition of bid responsiveness, the bidder must how it intend to comply with the Buy American preferences established under Title 49 U.S.C. Section 50101. Bidder must complete the attached Buy American certification. If the bidder requests a permissible waiver to the Buy America requirements, the Bidder identified as with the successful bid must submit a formal waiver request and component cost calculation within the prescribed time identified on the Buy America certification.

ATTACHMENTS TO THIS BID

The following documents are attached to and made a part of this Bid:

1. Completed Indiana State Board of Accounts Contractor's Bid For Public Works - Form 96
2. Bid Guaranty in the form of _____;
3. Completed "DBE Utilization Statement" and "Letter of Intent".
4. Evidence of good faith efforts required by 49 CFR Part 26, Appendix A. If proposed DBE goal is met, submittal of evidence of good faith efforts is not required.
5. Evidence of BIDDER'S qualifications per the requirements of the Instructions-to-Bidders.

SIGNATURE OF BIDDER

IF AN INDIVIDUAL:

Name: _____
By: _____
(Signature of Individual)
Doing Business as: _____
Business Address: _____

Telephone Number: _____

IF A PARTNERSHIP:

Partnership Name: _____
By: _____
(Authorized Signature)
(Attach Evidence of Authority to sign as a Partnership)
Name and Title: _____
Business Address: _____

Telephone Number: _____

IF A CORPORATION:

Corporation Name: _____
By: _____
(Authorized Signature)
(Attach Evidence of Authority to sign)
Name and Title: _____
Business Address: _____ (CORPORATE SEAL)

Telephone Number: _____

ATTEST:

By: _____
(Authorized Signature)
Name and Title: _____

IF A JOINT VENTURE: *(Attach copy of Joint Venture Agreement)*

Joint Venture Name: _____

By: _____
(Authorized Signature)
(Attach Evidence of Authority to sign)

Name and Title: _____

Business Address: _____

Telephone Number: _____

Joint Venture Name: _____

By: _____
(Authorized Signature)
(Attach Evidence of Authority to sign)

Name and Title: _____

Business Address: _____

Telephone Number: _____

A4 BUY AMERICAN PREFERENCE

(References: Title 49 USC § 50101, Executive Order 14005, *Ensuring the Future is Made in All of America by All of America's Workers*, Bipartisan Infrastructure Law (Pub. L. No. 117-58), Build America, Buy America (BABA))

The Contractor certifies that its bid/offer is in compliance with 49 USC § 50101, BABA and other related Made in America Laws,¹ U.S. statutes, guidance, and FAA policies, which provide that Federal funds may not be obligated unless all iron, steel and manufactured goods used in AIP funded projects are produced in the United States, unless the Federal Aviation Administration has issued a waiver for the product; the product is listed as an Excepted Article, Material Or Supply in Federal Acquisition Regulation subpart 25.108; or is included in the FAA Nationwide Buy American Waivers Issued list.

The bidder or offeror must complete and submit the certification of compliance with FAA's Buy American Preference, BABA and Made in America laws included herein with their bid or offer. The Airport Sponsor/Owner will reject as nonresponsive any bid or offer that does not include a completed certification of compliance with FAA's Buy American Preference and BABA.

The bidder or offeror certifies that all constructions materials, defined to mean an article, material, or supply other than an item of primarily iron or steel; a manufactured product; cement and cementitious materials; aggregates such as stone, sand, or gravel; or aggregate binding agents or additives that are or consist primarily of: non-ferrous metals; plastic and polymer-based products (including polyvinylchloride, composite building materials, and polymers used in fiber optic cables); glass (including optic glass); lumber; or drywall used in the project are manufactured in the U.S.

¹ Per Executive Order 14005 "Made in America Laws" means all statutes, regulations, rules, and Executive Orders relating to federal financial assistance awards or federal procurement, including those that refer to "Buy America" or "Buy American," that require, or provide a preference for, the purchase or acquisition of goods, products, or materials produced in the United States, including iron, steel, and manufactured products offered in the United States.

A4.3.2 Certification of Compliance with FAA Buy American Preference – Construction Projects

As a matter of bid responsiveness, the bidder or offeror must complete, sign, date, and submit this certification statement with its proposal. The bidder or offeror must indicate how it intends to comply with 49 USC § 50101, BABA and other related Made in America Laws, U.S. statutes, guidance, and FAA policies, by selecting one of the following certification statements. These statements are mutually exclusive. Bidder must select one or the other (i.e., not both) by inserting a checkmark (✓) or the letter “X”.

- Bidder or offeror hereby certifies that it will comply with 49 USC § 50101, BABA and other related U.S. statutes, guidance, and policies of the FAA by:
 - a) Only installing iron, steel and manufactured products produced in the United States;
 - b) Only installing construction materials defined as: an article, material, or supply – other than an item of primarily iron or steel; a manufactured product; cement and cementitious materials; aggregates such as stone, sand, or gravel; or aggregate binding agents or additives that are or consist primarily of non-ferrous metals; plastic and polymer-based products (including polyvinylchloride, composite building materials, and polymers used in fiber optic cables); glass (including optic glass); lumber or drywall that have been manufactured in the United States.
 - c) Installing manufactured products for which the Federal Aviation Administration (FAA) has issued a waiver as indicated by inclusion on the current FAA Nationwide Buy American Waivers Issued listing; or
 - d) Installing products listed as an Excepted Article, Material or Supply in Federal Acquisition Regulation Subpart 25.108.

By selecting this certification statement, the bidder or offeror agrees:

- a) To provide to the Airport Sponsor or the FAA evidence that documents the source and origin of the iron, steel, and/or manufactured product.
 - b) To faithfully comply with providing U.S. domestic products.
 - c) To refrain from seeking a waiver request after establishment of the contract, unless extenuating circumstances emerge that the FAA determines justified.
 - d) Certify that all construction materials used in the project are manufactured in the U.S.

- The bidder or offeror hereby certifies it cannot comply with the 100 percent Buy American Preferences of 49 USC § 50101(a) but may qualify for a Type 3 or Type 4 waiver under 49 USC § 50101(b). By selecting this certification statement, the apparent bidder or offeror with the apparent low bid agrees:
 - a) To submit to the Airport Sponsor or FAA within 15 calendar days of being selected as the responsive bidder, a formal waiver request and required documentation that supports the type of waiver being requested.
 - b) That failure to submit the required documentation within the specified timeframe is cause for a non-responsive determination that may result in rejection of the proposal.
 - c) To faithfully comply with providing U.S. domestic products at or above the approved U.S. domestic content percentage as approved by the FAA.
 - d) To furnish U.S. domestic product for any waiver request that the FAA rejects.
 - e) To refrain from seeking a waiver request after establishment of the contract, unless extenuating circumstances emerge that the FAA determines justified.

Required Documentation

Type 2 Waiver (Nonavailability) - The iron, steel, manufactured goods or construction materials or manufactured goods are not available in sufficient quantity or quality in the United States. The required documentation for the Nonavailability waiver is

- a) Completed Content Percentage Worksheet and Final Assembly Questionnaire
- b) Record of thorough market research, consideration where appropriate of qualifying alternate items, products, or materials including;
- c) A description of the market research activities and methods used to identify domestically manufactured items capable of satisfying the requirement, including the timing of the research and conclusions reached on the availability of sources.

Type 3 Waiver – The cost of components and subcomponents produced in the United States is more than 60 percent of the cost of all components and subcomponents of the “facility/project.” The required documentation for a Type 3 waiver is:

- a) Completed Content Percentage Worksheet and Final Assembly Questionnaire including;
- b) Listing of all manufactured products that are not comprised of 100 percent U.S. domestic content (excludes products listed on the FAA Nationwide Buy American Waivers Issued listing and products excluded by Federal Acquisition Regulation Subpart 25.108; products of unknown origin must be considered as non-domestic products in their entirety).
- c) Cost of non-domestic components and subcomponents, excluding labor costs associated with final assembly and installation at project location.
- d) Percentage of non-domestic component and subcomponent cost as compared to total “facility” component and subcomponent costs, excluding labor costs associated with final assembly and installation at project location.

Type 4 Waiver (Unreasonable Costs) - Applying this provision for iron, steel, manufactured goods or construction materials would increase the cost of the overall project by more than 25 percent. The required documentation for this waiver is:

- a) A completed Content Percentage Worksheet and Final Assembly Questionnaire from
- b) At minimum two comparable equal bids and/or offers;
- c) Receipt or record that demonstrates that supplier scouting called for in Executive Order 14005, indicates that no domestic source exists for the project and/or component;
- d) Completed waiver applications for each comparable bid and/or offer.

False Statements: Per 49 USC § 47126, this certification concerns a matter within the jurisdiction of the Federal Aviation Administration and the making of a false, fictitious, or fraudulent certification may render the maker subject to prosecution under Title 18, United States Code.

Date

Signature

Company Name

Title

– CONFIDENTIAL –
NOT SUBJECT TO DISCLOSURE UNDER EXEMPTION # 4 OF THE FREEDOM OF INFORMATION ACT

Buy American Product Content Percentage Worksheet

Company Name: _____ Date: _____
 Address: _____ Point of Contact: _____
 Telephone: _____ Fax: _____ Email: _____

Product Structure: Multi-Level Bill of Materials (through level 2 only)

FAA Eligible Item: _____ FAA Item Number (if applicable): _____
 Total Material Cost: _____ US Content (%) (attach Certificate of Origin, US Customs Form 434, if applicable): _____ Other (%): _____

Address of Final Assembly Location: _____

The undersigned certifies that this information is true and accurate to the best of their knowledge. A false certification represents a violation of 18 U.S.C § 1001 and 49 U.S.C § 47126. Signatory has the burden of proof to establish compliance.

Signature: _____

Name: _____

Instruction: Items listed in Federal Acquisition Regulation Part 25.104 may be counted as US Origin but should include a note stating the item is exempt in 25.104.

Level codes: Level **0** is the final product; Level **1** is a component; Level **2** is a sub-component.

Level (0, 1, 2)	Part Number	Item Description	Quantity Per Unit	Unit of Measure	Price/Unit of Measure	US Origin Price/Unit of Measure	US Origin Cost/Each	Other Price/Unit of Measure	Other Cost/Each



**-- CONFIDENTIAL --
NOT SUBJECT TO DISCLOSURE UNDER EXEMPTION # 4
OF THE FREEDOM OF INFORMATION ACT**

Buy American Preferences – Final Assembly Questionnaire

To assist the Federal Aviation Administration (FAA) in making the determination of whether final assembly of the product occurs in the United States, please complete and submit this questionnaire when requesting a Buy American Waiver under 49 USC § 50101(b)(3)(A).

Company Name:

Date:

FAA Eligible Item:

FAA Item Number (if applicable):

Address of Final Assembly Location:

1. Provide a description of the assembly process occurring at the specified final location in the United States.
 - a. Describe the final assembly process and its various operations.

 - b. How long does the final assembly process take to complete?

2. Provide a description of the resources used to conduct the assembly of the product at the specified location in the United States.
 - a. How many employees are involved in the final assembly process and what is the general skill level of those employees?

 - b. What type of equipment is used during the final assembly process?

 - c. What is a rough estimate of the associated cost to conduct final assembly of the product at the specified location in the United States?

The undersigned certifies that this information is true and accurate to the best of their knowledge. A false certification represents a violation of 18 U.S.C § 1001 and 49 U.S.C § 47126. Signatory has the burden of proof to establish compliance.

Signature: _____

Name:

UTILIZATION STATEMENT Disadvantage Business Enterprise

The undersigned bidder/offeror has satisfied the requirements of the bid specification in the following manner. *(Please mark the appropriate box)*

The DBE goal established for this project is **5.3%**.

- The bidder/offeror is committed to a minimum of _____% DBE utilization on this contract, which meets the above DBE goal.
- The bidder/offeror, is unable to meet the above DBE goal. However commits to a minimum of _____% DBE utilization on this contract and also submits documentation, as an attachment, or within 5 working days after bid submittal and prior to award of project, demonstrating good faith efforts (GFE).

The undersigned hereby further assures that the information included herein is true and correct, and that the DBE firm(s) listed herein have agreed to perform a commercially useful function in the work items noted for each firm. The undersigned further understands that no changes to this statement may be made without prior approval from the Civil Right Staff of the Federal Aviation Administration.

Bidder's/Offeror's Firm Name

Signature

Date

DBE UTILIZATION SUMMARY

<u>Percentage</u>	<u>Contract Amount</u>	<u>DBE Amount</u>	<u>Contract</u>
DBE Prime Contractor	\$ _____ x 1.00 =	\$ _____	_____ %
DBE Subcontractor	\$ _____ x 1.00 =	\$ _____	_____ %
DBE Supplier	\$ _____ x 0.60 =	\$ _____	_____ %
DBE Manufacturer	\$ _____ x 1.00 =	\$ _____	_____ %
Total Amount DBE		\$ _____	_____ %
DBE Goal		\$ _____	_____ %

Note: If the total proposed DBE participation is less than the established DBE goal, Bidder must provide written documentation of the good faith efforts as required by 49 CFR Part 26. **DBE certification must be current in the state that the project is in.**

LETTER OF INTENT

Bidder/Offer Name: _____
 Address: _____
 City: _____ State: _____ Zip: _____
 IRS Number: _____
 Contact Name: _____ Telephone No.: _____

(Following shall be submitted for each firm)

Was the following firm selected by lowest bid? (check one) Yes: ___ No: ___

Firm: Name: _____
 Address: _____
 City: _____ State: _____ Zip: _____

Contact Person: Name: _____ Phone: () _____

Is firm a Small Business Enterprise (SBE)? (check one) Yes: ___ No: ___

Is firm a Disadvantaged Business Enterprise (DBE)? (check one) Yes: ___ No: ___

Classification: Prime Contractor Subcontractor Joint Venture
 Manufacturer Supplier

Work item(s) to be performed by Firm	Description of Work Item	Quantity	Total

The bidder/offeror is committed to utilizing the above-named firm for the work described above. The estimated participation is as follows:

Firm's contract amount: \$ _____ Percent of total contract: _____%

AFFIRMATION:

The above-named firm affirms that it will perform the portion of the contract for the estimated dollar value as stated above.

By: _____
(Signature) *(Title)*

Following for DBE Only

DBE Certifying Agency: _____ **Expiration Date:** _____
Each DBE Firm shall submit evidence (such as a photocopy) of their certification status

Note: In the event the bidder/offeror does not receive award of the prime contract, any and all representations in this Letter of Intent and Affirmation shall be null and void.



CONTRACTOR'S BID FOR PUBLIC WORK - FORM 96

State Form 52414 (R2 / 2-13) / Form 96 (Revised 2013)

Prescribed by State Board of Accounts

PART I

(To be completed for all bids. Please type or print)

Date (month, day, year): _____

1. Governmental Unit (Owner): _____

2. County : _____

3. Bidder (Firm): _____

Address: _____

City/State/ZIPcode: _____

4. Telephone Number: _____

5. Agent of Bidder (if applicable): _____

Pursuant to notices given, the undersigned offers to furnish labor and/or material necessary to complete the public works project of _____ (Governmental Unit) in accordance with plans and specifications prepared by _____ and dated _____ for the sum of \$ _____

The undersigned further agrees to furnish a bond or certified check with this bid for an amount specified in the notice of the letting. If alternative bids apply, the undersigned submits a proposal for each in accordance with the notice. Any addendums attached will be specifically referenced at the applicable page.

If additional units of material included in the contract are needed, the cost of units must be the same as that shown in the original contract if accepted by the governmental unit. If the bid is to be awarded on a unit basis, the itemization of the units shall be shown on a separate attachment.

The contractor and his subcontractors, if any, shall not discriminate against or intimidate any employee, or applicant for employment, to be employed in the performance of this contract, with respect to any matter directly or indirectly related to employment because of race, religion, color, sex, national origin or ancestry. Breach of this covenant may be regarded as a material breach of the contract.

CERTIFICATION OF USE OF UNITED STATES STEEL PRODUCTS

(If applicable)

I, the undersigned bidder or agent as a contractor on a public works project, understand my statutory obligation to use steel products made in the United States (I.C. 5-16-8-2). I hereby certify that I and all subcontractors employed by me for this project will use U.S. steel products on this project if awarded. I understand that violations hereunder may result in forfeiture of contractual payments.

ACCEPTANCE

The above bid is accepted this _____ day of _____, _____, subject to the following conditions: _____

Contracting Authority Members:

PART II

(For projects of \$150,000 or more – IC 36-1-12-4)

Governmental Unit: _____

Bidder (Firm) _____

Date (*month, day, year*): _____

These statements to be submitted under oath by each bidder with and as a part of his bid. Attach additional pages for each section as needed.

SECTION I EXPERIENCE QUESTIONNAIRE

1. What public works projects has your organization completed for the period of one (1) year prior to the date of the current bid?

Contract Amount	Class of Work	Completion Date	Name and Address of Owner

2. What public works projects are now in process of construction by your organization?

Contract Amount	Class of Work	Expected Completion Date	Name and Address of Owner

3. Have you ever failed to complete any work awarded to you? _____ If so, where and why?

4. List references from private firms for which you have performed work.

SECTION II PLAN AND EQUIPMENT QUESTIONNAIRE

1. Explain your plan or layout for performing proposed work. *(Examples could include a narrative of when you could begin work, complete the project, number of workers, etc. and any other information which you believe would enable the governmental unit to consider your bid.)*

2. Please list the names and addresses of all subcontractors *(i.e. persons or firms outside your own firm who have performed part of the work)* that you have used on public works projects during the past five (5) years along with a brief description of the work done by each subcontractor.

3. If you intend to sublet any portion of the work, state the name and address of each subcontractor, equipment to be used by the subcontractor, and whether you will require a bond. However, if you are unable to currently provide a listing, please understand a listing must be provided prior to contract approval. Until the completion of the proposed project, you are under a continuing obligation to immediately notify the governmental unit in the event that you subsequently determine that you will use a subcontractor on the proposed project.

4. What equipment do you have available to use for the proposed project? Any equipment to be used by subcontractors may also be required to be listed by the governmental unit.

5. Have you entered into contracts or received offers for all materials which substantiate the prices used in preparing your proposal? If not, please explain the rationale used which would corroborate the prices listed.

SECTION III CONTRACTOR'S FINANCIAL STATEMENT

Attachment of bidder's financial statement is mandatory. Any bid submitted without said financial statement as required by statute shall thereby be rendered invalid. The financial statement provided hereunder to the governing body awarding the contract must be specific enough in detail so that said governing body can make a proper determination of the bidder's capability for completing the project if awarded.

BID OF

(Contractor)

(Address)

FOR
PUBLIC WORKS PROJECTS
OF

Filed _____

Action taken _____

A24 TAX DELINQUENCY AND FELONY CONVICTIONS

(References: Section 8113 of the Consolidated Appropriations Act, 2022 (Public Law 117-103) and similar provisions in subsequent appropriations acts.

DOT Order 4200.6 – Appropriations Act Requirements for Procurement and Non-Procurement Regarding Tax Delinquency and Felony Convictions)

CERTIFICATION OF OFFEROR/BIDDER REGARDING TAX DELINQUENCY AND FELONY CONVICTIONS

The applicant must complete the following two certification statements. The applicant must indicate its current status as it relates to tax delinquency and felony conviction by inserting a checkmark (✓) in the space following the applicable response. The applicant agrees that, if awarded a contract resulting from this solicitation, it will incorporate this provision for certification in all lower tier subcontracts.

Certifications

The applicant represents that it is is not a corporation that has any unpaid Federal tax liability that has been assessed, for which all judicial and administrative remedies have been exhausted or have lapsed, and that is not being paid in a timely manner pursuant to an agreement with the authority responsible for collecting the tax liability.

The applicant represents that it is is not a corporation that was convicted of a criminal violation under any Federal law within the preceding 24 months.

Note

If an applicant responds in the affirmative to either of the above representations, the applicant is ineligible to receive an award unless the Sponsor has received notification from the agency suspension and debarment official (SDO) that the SDO has considered suspension or debarment and determined that further action is not required to protect the Government's interests. The applicant therefore must provide information to the owner about its tax liability or conviction to the Owner, who will then notify the FAA Airports District Office, which will then notify the agency's SDO to facilitate completion of the required considerations before award decisions are made.

Term Definitions

Felony conviction: Felony conviction means a conviction within the preceding twenty four (24) months of a felony criminal violation under any Federal law and includes conviction of an offense defined in a section of the U.S. Code that specifically classifies the offense as a felony and conviction of an offense that is classified as a felony under 18 USC § 3559.

Tax Delinquency: A tax delinquency is any unpaid Federal tax liability that has been assessed, for which all judicial and administrative remedies have been exhausted, or have lapsed, and that is not being paid in a timely manner pursuant to an agreement with the authority responsible for collecting the tax liability.

END OF PROPOSAL

NOTICE OF AWARD

TO: _____

PROJECT Description: Snow Removal Equipment Building

The OWNER has considered the BID submitted by you for the above described work in response to its Advertisement for Bids dated _____, 20 ____, Information for Bidders, and Proposal submitted on _____, 20 ____.

You are hereby notified that your BID has been accepted for items in the amount of \$ _____ Dollars (\$ _____).

You are required by the Information for Bidders to execute the Agreement and furnish the required CONTRACTOR'S Performance BOND, Payment BOND, and certificate of insurance within 10 calendar days from the date of this Notice to you.

If you fail to execute said Agreement and to furnish said BONDS within 10 days from the date of this Notice, said OWNER will be entitled to consider all your rights arising out of the OWNER'S acceptance of your BID as abandoned and as a forfeiture of your BID BOND. The OWNER will be entitled to such other rights as may be granted by law.

You are required to return an acknowledged copy of this NOTICE OF AWARD to the OWNER.

Dated this _____ day of _____, 20 ____.

RICHMOND BOARD OF AVIATION COMMISSIONERS
RICHMOND, INDIANA

By _____

Title _____

ACCEPTANCE OF NOTICE

Receipt of the above NOTICE OF AWARD is hereby acknowledged by _____
this the _____ day of _____, 20 ____.

By _____

Title _____

END OF NOTICE OF AWARD

CONSTRUCTION CONTRACTOR'S AGREEMENT
RICHMOND BOARD OF AVIATION COMMISSIONERS

THIS AGREEMENT, made effective as of {Insert Effective Date of Agreement} is

BY AND BETWEEN

the OWNER: RICHMOND BOARD OF AVIATION COMMISSIONERS
RICHMOND MUNICIPAL AIRPORT
5169 South State Road 227
RICHMOND, INDIANA 47374

And the CONTRACTOR: {Insert Name, Address, City/State/Zip Code}

WITNESSETH:

WHEREAS it is the intent of the Owner to make improvements at RICHMOND MUNICIPAL AIRPORT generally described as follows;

SNOW REMOVAL EQUIPMENT BUILDING

hereinafter referred to as the Project.

NOW THEREFORE in consideration of the mutual covenants hereinafter set forth, **OWNER and CONTRACTOR** agree as follows:

Article 1 - Work

It is hereby mutually agreed that for and in consideration of the payments as provided for herein to the CONTRACTOR by the OWNER, CONTRACTOR shall faithfully furnish all necessary labor, equipment, and material and shall fully perform all necessary work to complete the Project in strict accordance with this Contract Agreement and the Contract Documents.

Article 2 – Contract Documents

CONTRACTOR agrees that the Contract Documents consist of the following: this Agreement, Advertisement for Bid, General Provisions, Technical Provisions, Special Provisions, Drawings, all issued addenda, Instructions to Bidders, Proposal and associated attachments, Performance Bond, Payment Bond, Wage Rate Determination, Insurance certificates, documents incorporated by reference, documents incorporated by attachment, and all OWNER authorized change orders issued subsequent to the date of this agreement. All documents comprising the Contract Documents are complementary to one another and together establish the complete terms, conditions and obligations of the CONTRACTOR. All said Contract Documents are incorporated by reference into the Contract Agreement as if fully rewritten herein or attached thereto.

CONSTRUCTION CONTRACTOR'S AGREEMENT

Article 3 – Contract Price

In consideration of the faithful performance and completion of the Work by the CONTRACTOR in accordance with the Contract Documents, OWNER shall pay the CONTRACTOR an amount equal to:

\$ _____

subject to the following:

- a. Said amount is based on the schedule of prices and estimated quantities stated in CONTRACTOR'S Bid Proposal, which is attached to and made a part of this Agreement;
- b. Said amount is the aggregate sum of the result of the CONTRACTOR'S stated unit prices multiplied by the associated estimated quantities;
- c. CONTRACTOR and OWNER agree that said estimated quantities are not guaranteed and that the determination of actual quantities is to be made by the OWNER'S ENGINEER;
- d. Said amount is subject to modification for additions and deductions as provided for within the Contract General Provisions.

Article 4 – Payment

Upon the completion of the work and its acceptance by the OWNER, all sums due the CONTRACTOR by reason of faithful performance of the work, taking into consideration additions to or deductions from the Contract price by reason of alterations or modifications of the original Contract or by reason of "Extra Work" authorized under this Contract, will be paid to the CONTRACTOR by the OWNER after said completion and acceptance.

CONTRACTOR shall submit Applications for Payment in accordance the General Provisions. Applications for Payment will be processed by OWNER or ENGINEER as provided in the General Provisions.

The acceptance of final payment by the CONTRACTOR shall be considered as a release in full of all claims against the OWNER, arising out of, or by reason of, the work completed and materials furnished under this Contract.

OWNER shall make progress payments to the CONTRACTOR in accordance with the terms set forth in the General Provisions. Progress payments shall be based on estimates prepared by the ENGINEER for the value of work performed and materials completed in place in accordance with the Contract Drawings and Specifications.

Progress payments are subject to retainage requirements as set forth in the General Provisions.

In the event that all subcontractors, material suppliers, laborers, or those furnishing services have not been paid, the Owner shall withhold money from the Contract Price in an amount sufficient to pay all such outstanding claims. Any such claims paid by the Owner shall reduce the Contract Price. The Owner shall comply with the payment procedures set out in Indiana Code 36-1-12-12 and Indiana Code 36-1-12-13.

Article 5 – Contract Time

The CONTRACTOR agrees to commence work within ten (10) calendar days of the date specified in the OWNER'S Notice-to-Proceed. CONTRACTOR further agrees to complete said work within {insert # calendar days} of the commencement date stated within the Notice-to-Proceed.

It is expressly understood and agreed that the stated Contract Time is reasonable for the completion of the Work, taking all factors into consideration. Furthermore, extensions of the Contract Time may only be permitted by execution of a formal modification to this Contract Agreement in accordance with the General Provisions and as approved by the OWNER.

CONSTRUCTION CONTRACTOR'S AGREEMENT

Article 6 – Liquidated Damages

The CONTRACTOR and OWNER understand and agree that time is of essence for completion of the Work and that the OWNER will suffer additional expense and financial loss if said Work is not completed within the authorized Contract Time. Furthermore, the CONTRACTOR and OWNER recognize and understand the difficulty, delay, and expense in establishing the exact amount of actual financial loss and additional expense. Accordingly, in place of requiring such proof, the CONTRACTOR expressly agrees to pay the OWNER as liquidated damages the non-penal sum of \$ [REDACTED] per day for each calendar day required in excess of the authorized Contract Time.

Furthermore, the CONTRACTOR understands and agrees that;

- a. the OWNER has the right to deduct from any moneys due the CONTRACTOR, the amount of said liquidated damages;
- b. the OWNER has the right to recover the amount of said liquidated damages from the CONTRACTOR, SURETY or both.

Article 7 – CONTRACTOR'S Representations

The CONTRACTOR understands and agrees that all representations made by the CONTRACTOR within the Proposal shall apply under this Agreement as if fully rewritten herein.

Article 8 – CONTRACTOR'S Certifications

The CONTRACTOR understands and agrees that all certifications made by the CONTRACTOR within the Proposal shall apply under this Agreement as if fully rewritten herein. The CONTRACTOR further certifies the following;

- a. Certification of Eligibility (29 CFR Part 5.5)
 - i. By Entering into this contract, the CONTRACTOR certifies that neither he or she nor any person or firm who has an interest in the CONTRACTOR'S firm is a person or firm ineligible to be awarded Government contracts by virtue of Section 3(a) of the Davis-Bacon Act or 29 CFR 5.12(a)(1);
 - ii. No part of this contract shall be subcontracted to any person or firm ineligible for award of a Government contract by virtue of Section 3(a) of the Davis-Bacon Act or 29 CFR 5.12(a)(1);
 - iii. The penalty for making false statements is prescribed in the U.S. Criminal Code 18 U.S.C.
- b. Certification of Non-Segregated Facilities (41 CFR Part 60-1.8)

The federally-assisted construction CONTRACTOR, certifies that it does not maintain or provide, for its employees, any segregated facilities at any of its establishments and that it does not permit its employees to perform their services at any location, under its control, where segregated facilities are maintained. The BIDDER certifies that it will not maintain or provide, for its employees, segregated facilities at any of its establishments and that it will not permit its employees to perform their services at any location under its control where segregated facilities are maintained. The Bidder agrees that a breach of this certification is a violation of the Equal Opportunity Clause, which is to be incorporated in the contract.

As used in this certification, the term "segregated facilities" means any waiting rooms, work areas, restrooms, and washrooms, restaurants and other eating areas, timeclocks, locker rooms and other storage or dressing areas, parking lots, drinking fountains, recreation or entertainment areas, transportation, and housing facilities provided for employees which are segregated on the basis of race, color, religion, or national origin because of habit, local custom, or any other reason. The Bidder agrees that (except where it has obtained identical certifications from proposed subcontractors for specific time periods) it will obtain identical certifications from proposed subcontractors prior to the award of subcontracts exceeding

CONSTRUCTION CONTRACTOR'S AGREEMENT

\$10,000 which are not exempt from the provisions of the Equal Opportunity Clause and that it will retain such certifications in its files.

Article 9 – Miscellaneous

- a. CONTRACTOR understands that it shall be solely responsible for the means, methods, techniques, sequences and procedures of construction in connection with completion of the Work;
- b. CONTRACTOR understands and agrees that it shall not accomplish any work or furnish any materials that are not covered or authorized by the Contract Documents unless authorized in writing by the OWNER or ENGINEER;
- c. The rights of each party under this Agreement shall not be assigned or transferred to any other person, entity, firm or corporation without prior written consent of both parties;
- d. OWNER and CONTRACTOR each bind itself, their partners, successors, assigns and legal representatives to the other party in respect to all covenants, agreements, and obligations contained in the Contract Documents.
- e. Any provision or part of the Contract Documents held to be void or unenforceable under any Law or Regulation shall be deemed stricken, and all remaining provisions shall continue to be valid and binding upon OWNER and CONTRACTOR, who agree that the Contract Documents shall be reformed to replace such stricken provision or part thereof with a valid and enforceable provision that comes as close as possible to expressing the intention of the stricken provision.
- f. If within one year after the date of Substantial Completion, or such longer period of time as may be prescribed by Laws or Regulations of the terms of any applicable special guarantee required by the Contract Documents or by any specific provision of the Contract Documents, any work found to be unacceptable, Contractor shall promptly, without cost to Owner and in accordance with Owner's written instructions, either correct such unacceptable Work, or if it has been rejected by Owner, remove it from the site and replace it with acceptable Work. If Contractor does not promptly comply with the terms of such instructions, or in an emergency where delay would cause serious risk of loss or damage, Owner may have the unacceptable Work corrected or the rejected Work removed and replaced, and all direct, indirect, and consequential costs of such removal and replacement (including, but not limited to, fees and charges of engineers, architects, attorneys and other professionals) will be paid by Contractor. In special circumstances where a particular item of equipment is placed in continuous service before Substantial Completion of all the Work, the correction period for that item may start to run from an earlier date if so provided in the Specifications or by Written Amendment.
- g. If, instead of requiring correction or removal and replacement of unacceptable Work, Owner (and prior to Engineer's recommendation of final payment, also Engineer) prefers to accept it, Owner may do so. Contractor shall bear all direct, indirect and consequential costs attributable to Owner's evaluation of and determination to accept such unacceptable work (such costs to be approved by Engineer as to reasonableness and to include, but not be limited to, fees and charges of engineers, architects, attorneys and other professionals). If any such acceptance occurs prior to Engineer's recommendation of final payment, a Change Order will be issued incorporating the necessary revisions in the Contract Documents with respect to the Work, the Owner shall be entitled to an appropriate decrease in the Contract Price, and, if the parties are unable to agree as to the amount thereof, Owner may take a claim therefor, as provided in Section 90 of the General Provisions. If the acceptance occurs after such recommendation, an appropriate amount will be paid by Contractor to Owner.

CONSTRUCTION CONTRACTOR'S AGREEMENT

h. IT IS FURTHER AGREED AND UNDERSTOOD BY AND BETWEEN THE PARTIES HERETO, that the work to be performed under this contract are for the occupancy and use of OWNER and the CONTRACTOR hereunder expressly agrees that all the CONTRACTOR'S obligations, including guarantees, bonds and performance standards shall inure directly in favor of the OWNER its own name and right without the necessity of joining any other party of this Contract.

Article 10 – OWNER’S Representative

The OWNER’S Representative, herein referred to as ENGINEER, is defined as follows:

Butler, Fairman & Seufert, Inc.
8450 Westfield Boulevard, Suite 300
Indianapolis, IN 46240

Said ENGINEER will act as the OWNER’S representative and shall assume all rights and authority assigned to the ENGINEER as stated within the Contract Documents in connection with the completion of the Project Work.

IN WITNESS WHEREOF, OWNER and CONTRACTOR have executed five (5) copies of this Agreement on the day and year first noted herein.

OWNER

Name: _____

Address: _____

By: _____
Signature

Title of Representative

CONTRACTOR

Name: _____

Address: _____

By: _____
Signature

Title of Representative

ATTEST

By: _____
Signature

Title of Representative

ATTEST

By: _____
Signature

Title

CONSTRUCTION CONTRACTOR'S AGREEMENT

EXHIBIT A
CONTRACTOR'S BID PROPOSAL
Itemized Proposal Section

Insert Itemized Proposal from bid packet here

END OF CONSTRUCTION CONTRACT

CORPORATE RESOLUTION

BE IT RESOLVED, that the proposed contract (the "Contract") with _____
_____ (hereinafter "Owner"), as Owner, and this Corporation, as Contractor,
for _____, in the form submitted to this Board is hereby
approved.

BE IT FURTHER RESOLVED, that this Corporation shall furnish performance
and payment bonds (the "Bonds") in the amount of one hundred percent (100%) of
the amount of the Contract to Owner and to such other parties as Owner may
designate, with a good and sufficient surety acceptable to Owner, and the Bonds
and surety shall be in the usual form acceptable in the State of Indiana for work of
the nature covered by the Contract. The Bonds and such surety are hereby
approved.

BE IT FURTHER RESOLVED, that _____ of this
Corporation be and is hereby authorized and directed to execute, acknowledge, and deliver
the Contract and the Bonds for and on behalf of and in the name and as the act of this
Corporation with such changes therein not inconsistent with this Resolution and not
substantially adverse to this Corporation as may be approved by the officers, and that such
are not substantially adverse to this Corporation, shall be conclusively evidenced by the
execution of the Contract and the Bonds by such officers.

CERTIFICATION

I, _____, hereby certify:

1. That I am the duly elected Secretary of _____
_____ (the "Corporation") and as such am
authorized to execute and deliver this Certificate and have in my possession and under my
direct supervision, records and minutes of the meetings of the board of Directors of the
Corporation.

2. The foregoing is a true, correct and complete copy of the Resolutions duly adopted by
the Corporation's Board of Directors at a meeting duly convened and held on

_____, 20_____, at which a quorum was present and acting throughout, which Resolutions have not been altered, amended, or repealed, have been in full force and effect at all times since the date of their adoption and are in full force and effect on the date hereof.

3. Each person, who as an officer of the Corporation, executed the Contract and the Performance and Payment Bond authorized by said Resolution, was duly elected or appointed, qualified and acting as such officer at the time of such execution and delivery of the Contract and the Performance and Payment Bond, and the signatures of such persons appearing on the Contract and the Performance and Payment Bond are their true and genuine signatures. The Contract and the Performance and Payment Bond, as executed, were in substantially the form presented to said Board of Directors as referred to in said Resolution.

Dated: _____, 20_____.

Secretary

END OF CORPORATE RESOLUTION

PERFORMANCE BOND

Any singular reference to Contractor, Surety, Owner, or other party shall be considered plural where applicable.

CONTRACTOR (*Name and Address*):

SURETY (*Name, and Address of Principal Place of Business*):

OWNER (*Name and Address*):

CONTRACT

Effective Date of Agreement:

Amount:

Description (*Name and Location*):

BOND

Bond Number:

Date (*Not earlier than Effective Date of Agreement*):

Amount:

Modifications to this Bond Form:

Surety and Contractor, intending to be legally bound hereby, subject to the terms set forth below, do each cause this Performance Bond to be duly executed by an authorized officer, agent, or representative.

CONTRACTOR AS PRINCIPAL

SURETY

Contractor's Name and Corporate Seal (Seal)

Surety's Name and Corporate Seal (Seal)

By: _____
Signature

By: _____
Signature (Attach Power of Attorney)

Print Name

Print Name

Title

Title

Attest: _____
Signature

Attest: _____
Signature

Title

Title

Note: Provide execution by additional parties, such as joint venturers, if necessary.

Contractor and Surety, jointly and severally, bind themselves, their heirs, executors, administrators, successors, and assigns to Owner for the performance of the Contract, which is incorporated herein by reference.

1. If Contractor performs the Contract, Surety and Contractor have no obligation under this Bond, except to participate in conferences as provided in Paragraph 2.1.
2. If there is no Owner Default, Surety's obligation under this Bond shall arise after:
 - 2.1 Owner has notified Contractor and Surety, at the addresses described in Paragraph 9 below, that Owner is considering declaring a Contractor Default and has requested and attempted to arrange a conference with Contractor and Surety to be held not later than 15 days after receipt of such notice to discuss methods of performing the Contract. If Owner, Contractor, and Surety agree, Contractor shall be allowed a reasonable time to perform the Contract, but such an agreement shall not waive Owner's right, if any, subsequently to declare a Contractor Default; and
 - 2.2 Owner has declared a Contractor Default and formally terminated Contractor's right to complete the Contract. Such Contractor Default shall not be declared earlier than 20 days after Contractor and Surety have received notice as provided in Paragraph 2.1; and
 - 2.3 Owner has agreed to pay the Balance of the Contract Price to:
 1. Surety in accordance with the terms of the Contract; or
 2. Another contractor selected pursuant to Paragraph 3.3 to perform the Contract.
3. When Owner has satisfied the conditions of Paragraph 2, Surety shall promptly, and at Surety's expense, take one of the following actions:
 - 3.1 Arrange for Contractor, with consent of Owner, to perform and complete the Contract; or
 - 3.2 Undertake to perform and complete the Contract itself, through its agents or through independent contractors; or
 - 3.3 Obtain bids or negotiated proposals from qualified contractors acceptable to Owner for a contract for performance and completion of the Contract, arrange for a contract to be prepared for execution by Owner and contractor selected with Owner's concurrence, to be secured with performance and payment bonds executed by a qualified surety equivalent to the bonds issued on the Contract, and pay to Owner the amount of damages as described in Paragraph 5 in excess of the Balance of the Contract Price incurred by Owner resulting from Contractor Default; or
 - 3.4 Waive its right to perform and complete, arrange for completion, or obtain a new contractor, and with reasonable promptness under the circumstances:
 1. After investigation, determine the amount for which it may be liable to Owner and, as soon as practicable after the amount is determined, tender payment therefor to Owner; or
 2. Deny liability in whole or in part and notify Owner citing reasons therefor.
4. If Surety does not proceed as provided in Paragraph 3 with reasonable promptness, Surety shall be deemed to be in default on this Bond 15 days after receipt of an additional written notice from Owner to Surety demanding that Surety perform its obligations under this Bond, and Owner shall be entitled to enforce any remedy available to Owner. If Surety proceeds as provided in Paragraph 3.4, and Owner refuses the payment tendered or Surety has denied liability, in whole or in part, without further notice Owner shall be entitled to enforce any remedy available to Owner.
5. After Owner has terminated Contractor's right to complete the Contract, and if Surety elects to act under Paragraph 3.1, 3.2, or 3.3 above, then the responsibilities of Surety to Owner shall not be greater than those of Contractor under the Contract, and the responsibilities of Owner to Surety shall not be greater than those of Owner under the Contract. To the limit of the amount of this Bond, but subject to commitment by Owner of the Balance of the Contract Price to mitigation of costs and damages on the Contract, Surety is obligated without duplication for:

- 5.1 The responsibilities of Contractor for correction of defective Work and completion of the Contract;
 - 5.2 Additional legal, design professional, and delay costs resulting from Contractor's Default, and resulting from the actions of or failure to act of Surety under Paragraph 3; and
 - 5.3 Liquidated damages, or if no liquidated damages are specified in the Contract, actual damages caused by delayed performance or non-performance of Contractor.
- 6. Surety shall not be liable to Owner or others for obligations of Contractor that are unrelated to the Contract, and the Balance of the Contract Price shall not be reduced or set off on account of any such unrelated obligations. No right of action shall accrue on this Bond to any person or entity other than Owner or its heirs, executors, administrators, or successors.
 - 7. Surety hereby waives notice of any change, including changes of time, to Contract or to related subcontracts, purchase orders, and other obligations.
 - 8. Any proceeding, legal or equitable, under this Bond may be instituted in any court of competent jurisdiction in the location in which the Work or part of the Work is located, and shall be instituted within two years after Contractor Default or within two years after Contractor ceased working or within two years after Surety refuses or fails to perform its obligations under this Bond, whichever occurs first. If the provisions of this paragraph are void or prohibited by law, the minimum period of limitation available to sureties as a defense in the jurisdiction of the suit shall be applicable.
 - 9. Notice to Surety, Owner, or Contractor shall be mailed or delivered to the address shown on the signature page.
 - 10. When this Bond has been furnished to comply with a statutory requirement in the location where the Contract was to be performed, any provision in this Bond conflicting with said statutory requirement shall be deemed deleted herefrom and provisions conforming to such statutory requirement shall be deemed incorporated herein. The intent is that this Bond shall be construed as a statutory bond and not as a common law bond.
 - 11. Definitions.
 - 11.1 Balance of the Contract Price: The total amount payable by Owner to Contractor under the Contract after all proper adjustments have been made, including allowance to Contractor of any amounts received or to be received by Owner in settlement of insurance or other Claims for damages to which Contractor is entitled, reduced by all valid and proper payments made to or on behalf of Contractor under the Contract.
 - 11.2 Contract: The agreement between Owner and Contractor identified on the signature page, including all Contract Documents and changes thereto.
 - 11.3 Contractor Default: Failure of Contractor, which has neither been remedied nor waived, to perform or otherwise to comply with the terms of the Contract.
 - 11.4 Owner Default: Failure of Owner, which has neither been remedied nor waived, to pay Contractor as required by the Contract or to perform and complete or otherwise comply with the other terms thereof.

FOR INFORMATION ONLY – *(Name, Address and Telephone)*
 Surety Agency or Broker:
 Owner's Representative *(Engineer or other party)*:

END OF PERFORMANCE BOND

1. Contractor and Surety, jointly and severally, bind themselves, their heirs, executors, administrators, successors, and assigns to Owner to pay for labor, materials, and equipment furnished by Claimants for use in the performance of the Contract, which is incorporated herein by reference.
2. With respect to Owner, this obligation shall be null and void if Contractor:
 - 2.1 Promptly makes payment, directly or indirectly, for all sums due Claimants, and
 - 2.2 Defends, indemnifies, and holds harmless Owner from all claims, demands, liens, or suits alleging non-payment by Contractor by any person or entity who furnished labor, materials, or equipment for use in the performance of the Contract, provided Owner has promptly notified Contractor and Surety (at the addresses described in Paragraph 12) of any claims, demands, liens, or suits and tendered defense of such claims, demands, liens, or suits to Contractor and Surety, and provided there is no Owner Default.
3. With respect to Claimants, this obligation shall be null and void if Contractor promptly makes payment, directly or indirectly, for all sums due.
4. Surety shall have no obligation to Claimants under this Bond until:
 - 4.1 Claimants who are employed by or have a direct contract with Contractor have given notice to Surety (at the address described in Paragraph 12) and sent a copy, or notice thereof, to Owner, stating that a claim is being made under this Bond and, with substantial accuracy, the amount of the claim.
 - 4.2 Claimants who do not have a direct contract with Contractor:
 1. Have furnished written notice to Contractor and sent a copy, or notice thereof, to Owner, within 90 days after having last performed labor or last furnished materials or equipment included in the claim stating, with substantial accuracy, the amount of the claim and the name of the party to whom the materials or equipment were furnished or supplied, or for whom the labor was done or performed; and
 2. Have either received a rejection in whole or in part from Contractor, or not received within 30 days of furnishing the above notice any communication from Contractor by which Contractor had indicated the claim will be paid directly or indirectly; and
 3. Not having been paid within the above 30 days, have sent a written notice to Surety (at the address described in Paragraph 12) and sent a copy, or notice thereof, to Owner, stating that a claim is being made under this Bond and enclosing a copy of the previous written notice furnished to Contractor.
5. If a notice by a Claimant required by Paragraph 4 is provided by Owner to Contractor or to Surety, that is sufficient compliance.
6. Reserved.
7. Surety's total obligation shall not exceed the amount of this Bond, and the amount of this Bond shall be credited for any payments made in good faith by Surety.
8. Amounts owed by Owner to Contractor under the Contract shall be used for the performance of the Contract and to satisfy claims, if any, under any performance bond. By Contractor furnishing and Owner accepting this Bond, they agree that all funds earned by Contractor in the performance of the Contract are dedicated to satisfy obligations of Contractor and Surety under this Bond, subject to Owner's priority to use the funds for the completion of the Work.
9. Surety shall not be liable to Owner, Claimants, or others for obligations of Contractor that are unrelated to the Contract. Owner shall not be liable for payment of any costs or expenses of any Claimant under this

Bond, and shall have under this Bond no obligations to make payments to, give notices on behalf of, or otherwise have obligations to Claimants under this Bond.

10. Surety hereby waives notice of any change, including changes of time, to the Contract or to related subcontracts, purchase orders, and other obligations.
11. No suit or action shall be commenced by a Claimant under this Bond other than in a court of competent jurisdiction in the location in which the Work or part of the Work is located or after the expiration of one year from the date (1) on which the Claimant gave the notice required by Paragraph 4.1 or Paragraph 4.2.3, or (2) on which the last labor or service was performed by anyone or the last materials or equipment were furnished by anyone under the Contract, whichever of (1) or (2) first occurs. If the provisions of this paragraph are void or prohibited by law, the minimum period of limitation available to sureties as a defense in the jurisdiction of the suit shall be applicable.
12. Notice to Surety, Owner, or Contractor shall be mailed or delivered to the addresses shown on the signature page. Actual receipt of notice by Surety, Owner, or Contractor, however accomplished, shall be sufficient compliance as of the date received at the address shown on the signature page.
13. When this Bond has been furnished to comply with a statutory requirement in the location where the Contract was to be performed, any provision in this Bond conflicting with said statutory requirement shall be deemed deleted herefrom and provisions conforming to such statutory requirement shall be deemed incorporated herein. The intent is that this Bond shall be construed as a statutory Bond and not as a common law bond.
14. Upon request of any person or entity appearing to be a potential beneficiary of this Bond, Contractor shall promptly furnish a copy of this Bond or shall permit a copy to be made.
15. Definitions
 - 15.1 Claimant: An individual or entity having a direct contract with Contractor, or with a first-tier subcontractor of Contractor, to furnish labor, materials, or equipment for use in the performance of the Contract. The intent of this Bond shall be to include without limitation in the terms "labor, materials or equipment" that part of water, gas, power, light, heat, oil, gasoline, telephone service, or rental equipment used in the Contract, architectural and engineering services required for performance of the Work of Contractor and Contractor's subcontractors, and all other items for which a mechanic's lien may be asserted in the jurisdiction where the labor, materials, or equipment were furnished.
 - 15.2 Contract: The agreement between Owner and Contractor identified on the signature page, including all Contract Documents and changes thereto.
 - 15.3 Owner Default: Failure of Owner, which has neither been remedied nor waived, to pay Contractor as required by the Contract, or to perform and complete or otherwise comply with the other terms thereof.

FOR INFORMATION ONLY – (Name, Address, and Telephone) Surety Agency or Broker: Owner's Representative (<i>Engineer or other</i>):

END OF PAYMENT BOND

ALSO INCLUDE WITH CONTRACT, THE FOLLOWING:

CERTIFICATE OF INSURANCE

**AC 150/5370-2G SAFETY PLAN COMPLIANCE DOCUMENT (SPCD)
WORKSHEET FOR AIRPORT PROJECTS**

Contractor's Responsibility

Following Federal Aviation Administration Advisory Circular 150/5370-2G, this SPCD shall be submitted to the Engineer and to the airport operator for review and approval. This should be submitted 14 days prior to the preconstruction conference. The notice-to-proceed cannot be issued without approval of this document.

The SPCD shall be prepared in a detailed, written and pictorial format (if needed) that identifies the timing and methodology for the contractor's compliance with the project's Construction Safety and Phasing Plan (CSPP) located in the construction plans & specifications. Any proposed alteration by the contractor from the CSPP shall be fully explained so a thorough analysis and determination can be made of the proposed modification.

Project Information

Project ID: _____ Airport: _____

Description of Project: _____

Type of Work: _____

Prime Contractor: _____

Address: _____

Contractor Contact: _____ Phone: _____

BOA Project Manager: _____ Phone: _____

Airport Operator Contact: _____ Phone: _____

The following shall complement the safety plan compliance document:

1. Contractor shall have copies of the CSPP and SPCD available at all times for reference by the airport operator and its representatives, and by subcontractors and contractor employees.

Location(s) of CSPP and SPCD: _____

2. Provide a point of contact who will coordinate an immediate response to correct any construction-related activity that may adversely affect the operational safety of the airport. Project will require 24-hour coverage.

Point of Contact: _____ Phone: _____

3. Contractor's on-site employees responsible for monitoring compliance with the CSPP and SPCD whenever active construction is taking place.

Contact Person: _____ Phone: _____

Contact Person: _____ Phone: _____

4. The contractor shall list all proposed deviations or modifications to the CSPP. For each alteration the contractor shall provide:
 - a. The reason why the alteration is desired.
 - b. Provide sufficient narrative description and/or pictorial descriptions of the proposed change so a complete review of the proposal can be made.
 - c. If no alterations are to be made to the CSPP, clearly state; **“No alterations to the CSPP are proposed.”**

The following are proposed deviations or modifications to the CSPP:

(Attach additional sheets as needed)

5. The contractor shall provide a list of the specific hazard equipment and lighting that will be employed to ensure compliance with the.

The following are proposed hazard equipment and lighting for the project:

(Attach additional sheets as needed)

6. The contractor shall describe the frequency of inspections to ensure construction personnel comply with the CSPP and SPCD and that there are no altered construction activities that could create potential safety hazards. Inspections shall ensure that all proper safety devices, signs, demarcations etc. are in place and in proper working order in accordance with the approved CSPP & SPCD. A Construction Project Daily Safety Inspection Checklist is attached to aid in making a thorough inspection.

The inspection frequency will be _____

7. Provide a description and schedule for any anticipated supplemental submittal through the airport operator of Form 7460-1 for the purpose of conducting an aeronautical study of contractor equipment such as tall equipment (cranes, concrete pumps, other equipment), stock piles, and haul routes when different from cases previously filed as part of the CSPP.

An additional Form 7460-1 will/will not (circle one) be required. If additional Forms 7460-1 will be required, they will be submitted by _____

8. Provide a description of contractor’s plan to ensure that construction personnel are familiar with the safety procedures and regulations on the airport, the CSPP, and the SPCD.

(Attach additional sheets as needed)

SPCD Amendment

The SPCD shall be amended any time there is a construction practice proposed by the contractor that does not conform to the CSPP and SPCD and may impact the airport's operational safety. This will require a revision to the CSPP and SPCD and re-coordination with the airport operator and the FAA in advance.

Certification

I certify that we understand the operational safety requirements of the CSPP and assert that we will not deviate from the approved CSPP and SPCD unless written approval is granted by the airport operator.

Print Name: _____ Title: _____

Signature: _____ Date: _____

Note to Contractor: Please provide copies of your company's general safety policy as an attachment.

Construction Project Daily Safety Inspection Checklist

The situations identified below are potentially hazardous conditions that may occur during airport construction projects. Safety area encroachments, unauthorized and improper ground vehicle operations, and unmarked or uncovered holes and trenches near aircraft operating surfaces pose the most prevalent threats to airport operational safety during airport construction projects. The list below is one tool that the airport operator or contractor may use to aid in identifying and correcting potentially hazardous conditions. It should be customized as appropriate for each project.

Potentially Hazardous Conditions

Item	Action Required	or	None
Excavation adjacent to runways, taxiways, and aprons improperly backfilled.			
Mounds of earth, construction materials, temporary structures, and other obstacles near any open runway, taxiway, or taxi lane; in the related Object Free area and aircraft approach or departure areas/zones; or obstructing any sign or marking.			
Runway resurfacing projects resulting in lips exceeding 3 in (7.6 cm) from pavement edges and ends.			
Heavy equipment (stationary or mobile) operating or idle near AOA, in runway approaches and departures areas, or in OFZ.			
Equipment or material near NAVAIDs that may degrade or impair radiated signals and/or the monitoring of navigation and visual aids. Unauthorized or improper vehicle operations in localizer or glide slope critical areas, resulting in electronic interference and/or facility shutdown.			
Tall and especially relatively low visibility units (that is, equipment with slim profiles) — cranes, drills, and similar objects — located in critical areas, such as OFZ and approach zones.			
Improperly positioned or malfunctioning lights or unlighted airport hazards, such as holes or excavations, on any apron, open taxiway, or open taxi lane or in a related safety, approach, or departure area.			
Obstacles, loose pavement, trash, and other debris on or near AOA. Construction debris (gravel, sand, mud, paving materials) on airport pavements may result in aircraft propeller, turbine engine, or tire damage. Also, loose materials may blow about, potentially causing personal injury or equipment damage.			

Item	Action Required	or	None
Inappropriate or poorly maintained fencing during construction intended to deter human and animal intrusions into the AOA. Fencing and other markings that are inadequate to separate construction areas from open AOA create aviation hazards.			
Improper or inadequate marking or lighting of runways (especially thresholds that have been displaced or runways that have been closed) and taxiways that could cause pilot confusion and provide a potential for a runway incursion. Inadequate or improper methods of marking, barricading, and lighting of temporarily closed portions of AOA create aviation hazards.			
Wildlife attractants — such as trash (food scraps not collected from construction personnel activity), grass seeds, tall grass, or standing water — on or near airports.			
Obliterated or faded temporary markings on active operational areas.			
Misleading or malfunctioning obstruction lights. Unlighted or unmarked obstructions in the approach to any open runway pose aviation hazards.			
Failure to issue, update, or cancel NOTAMs about airport or runway closures or other construction related airport conditions.			
Failure to mark and identify utilities or power cables. Damage to utilities and power cables during construction activity can result in the loss of runway / taxiway lighting; loss of navigation, visual, or approach aids; disruption of weather reporting services; and/or loss of communications.			
Restrictions on ARFF access from fire stations to the runway / taxiway system or airport buildings.			
Lack of radio communications with construction vehicles in airport movement areas.			
Objects, regardless of whether they are marked or flagged, or activities anywhere on or near an airport that could be distracting, confusing, or alarming to pilots during aircraft operations.			
Water, snow, dirt, debris, or other contaminants that temporarily obscure or derogate the visibility of runway/taxiway marking, lighting, and pavement edges. Any condition or factor that obscures or diminishes the visibility of areas under construction.			
Spillage from vehicles (gasoline, diesel fuel, oil) on active pavement areas, such as runways, taxiways, aprons, and airport roadways.			

Item	Action Required	or	None
Failure to maintain drainage system integrity during construction (for example, no temporary drainage provided when working on a drainage system).			
Failure to provide for proper electrical lockout and tagging procedures. At larger airports with multiple maintenance shifts/workers, construction contractors should make provisions for coordinating work on circuits.			
Failure to control dust. Consider limiting the amount of area from which the contractor is allowed to strip turf.			
Exposed wiring that creates an electrocution or fire ignition hazard. Identify and secure wiring, and place it in conduit or bury it.			
Site burning, which can cause possible obscuration.			
Construction work taking place outside of designated work areas and out of phase.			

NOTICE TO PROCEED

TO: _____ Date: _____

_____ Project: _____

You are hereby notified under authority of the Board on _____, 20____, to commence WORK in accordance with the Contract dated _____, 20____, on or before _____, 20____, and you are to complete the WORK within consecutive _____ calendar days thereafter. The date of completion of all WORK is therefore _____, 20____.

RICHMOND BOARD OF AVIATION COMMISSIONERS
RICHMOND, INDIANA

By _____
Title _____

ACCEPTANCE OF NOTICE

Receipt of the above NOTICE TO PROCEED is hereby acknowledged by _____
_____ this the _____ day of _____, 20____.

By _____
Title _____

END OF NOTICE TO PROCEED

Federal Provisions

Table of Contents

A1	ACCESS TO RECORDS AND REPORTS	FP-3
A2	AFFIRMATIVE ACTION REQUIREMENT	FP-4
A3	BREACH OF CONTRACT TERMS	FP-5
A4	BUY AMERICAN PREFERENCE	FP-6
A5	CIVIL RIGHTS - GENERAL	FP-9
A6	CIVIL RIGHTS – TITLE VI ASSURANCE	FP-10
A7	CLEAN AIR AND WATER POLLUTION CONTROL	FP-12
A8	CONTRACT WORKHOURS AND SAFETY STANDARDS ACT REQUIREMENTS	FP-13
A9	COPELAND “ANTI-KICKBACK” ACT	FP-14
A10	DAVIS-BACON REQUIREMENTS	FP-15
A11	DEBARMENT AND SUSPENSION	FP-20
A12	DISADVANTAGED BUSINESS ENTERPRISE	FP-21
A13	DISTRACTED DRIVING	FP-23
A14	PROHIBITION ON CERTAIN TELECOMMUNICATIONS AND VIDEO SURVEILLANCE SERVICES OR EQUIPMENT	FP-23
A15	DRUG FREE WORKPLACE REQUIREMENTS.....	FP-23
A16	EQUAL EMPLOYMENT OPPORTUNITY (EEO)	FP-24
A17	FEDERAL FAIR LABOR STANDARDS ACT (FEDERAL MINIMUM WAGE)	FP- 30
A18	LOBBYING AND INFLUENCING FEDERAL EMPLOYEES	FP-30
A19	PROHIBITION of SEGREGATED FACILITIES	FP-31
A20	OCCUPATIONAL SAFETY AND HEALTH ACT OF 1970	FP-31
A21	PROCUREMENT OF RECOVERED MATERIALS	FP-32
A22	RIGHT TO INVENTIONS	FP-32
A23	SEISMIC SAFETY	FP-32
A24	TAX DELINQUENCY AND FELONY CONVICTIONS	FP-33
A25	TERMINATION OF CONTRACT	FP-34
A26	TRADE RESTRICTION CERTIFICATION	FP-35
A27	VETERAN’S PREFERENCE	FP-36
A28	DOMESTIC PREFERENCES FOR PROCUREMENTS	FP-36

A1 ACCESS TO RECORDS AND REPORTS

(References: 2 CFR § 200.334, 2 CFR § 200.337, FAA Order 5100.38)

The Contractor must maintain an acceptable cost accounting system. The Contractor agrees to provide the Owner, the Federal Aviation Administration and the Comptroller General of the United States or any of their duly authorized representatives access to any books, documents, papers and records of the Contractor which are directly pertinent to the specific contract for the purpose of making audit, examination, excerpts and transcriptions. The Contractor agrees to maintain all books, records and reports required under this contract for a period of not less than three years after final payment is made and all pending matters are closed.

A2 AFFIRMATIVE ACTION REQUIREMENT

(References: 41 CFR Part 60-4, Executive Order 11246)

1. The Offeror's or Bidder's attention is called to the "Equal Opportunity Clause" and the "Standard Federal Equal Employment Opportunity Construction Contract Specifications" set forth herein.
2. The goals and timetables for minority and female participation, expressed in percentage terms for the Contractor's aggregate workforce in each trade on all construction work in the covered area, are as follows:

Timetables

Goals for minority participation for each trade: 12.5%

Goals for female participation in each trade: 6.9%

These goals are applicable to all of the Contractor's construction work (whether or not it is Federal or federally assisted) performed in the covered area. If the Contractor performs construction work in a geographical area located outside of the covered area, it shall apply the goals established for such geographical area where the work is actually performed. With regard to this second area, the Contractor also is subject to the goals for both its federally involved and nonfederally involved construction.

The Contractor's compliance with the Executive Order and the regulations in 41 CFR Part 60-4 shall be based on its implementation of the Equal Opportunity Clause, specific affirmative action obligations required by the specifications set forth in 41 CFR 60-4.3(a) and its efforts to meet the goals. The hours of minority and female employment and training must be substantially uniform throughout the length of the contract, and in each trade, and the Contractor shall make a good faith effort to employ minorities and women evenly on each of its projects. The transfer of minority or female employees or trainees from Contractor to Contractor or from project to project for the sole purpose of meeting the Contractor's goals shall be a violation of the contract, the Executive Order and the regulations in 41 CFR Part 60-4. Compliance with the goals will be measured against the total work hours performed.

3. The Contractor shall provide written notification to the Director of the Office of Federal Contract Compliance Programs (OFCCP) within 10 working days of award of any construction subcontract in excess of \$10,000 at any tier for construction work under the contract resulting from this solicitation. The notification shall list the name, address, and telephone number of the subcontractor; employer identification number of the subcontractor; estimated dollar amount of the subcontract; estimated starting and completion dates of the subcontract; and the geographical area in which the subcontract is to be performed.
4. As used in this notice and in the contract resulting from this solicitation, the "covered area" is **[Wayne County, Richmond, IN]**.

A3 BREACH OF CONTRACT TERMS

(References: 2 CFR Part 200, Appendix II(A))

Any violation or breach of terms of this contract on the part of the *Contractor* or its subcontractors may result in the suspension or termination of this contract or such other action that may be necessary to enforce the rights of the parties of this agreement.

Owner will provide *Contractor* written notice that describes the nature of the breach and corrective actions the *Contractor* must undertake in order to avoid termination of the contract. Owner reserves the right to withhold payments to Contractor until such time the Contractor corrects the breach or the Owner elects to terminate the contract. The Owner's notice will identify a specific date by which the *Contractor* must correct the breach. Owner may proceed with termination of the contract if the *Contractor* fails to correct the breach by the deadline indicated in the Owner's notice.

The duties and obligations imposed by the Contract Documents and the rights and remedies available thereunder are in addition to, and not a limitation of, any duties, obligations, rights and remedies otherwise imposed or available by law.

A4 BUY AMERICAN PREFERENCE

(References: Title 49 USC § 50101, Executive Order 14005, *Ensuring the Future is Made in All of America by All of America's Workers*, Bipartisan Infrastructure Law (Pub. L. No. 117-58), Build America, Buy America (BABA))

The Contractor certifies that its bid/offer is in compliance with 49 USC § 50101, BABA and other related Made in America Laws,¹ U.S. statutes, guidance, and FAA policies, which provide that Federal funds may not be obligated unless all iron, steel and manufactured goods used in AIP funded projects are produced in the United States, unless the Federal Aviation Administration has issued a waiver for the product; the product is listed as an Excepted Article, Material Or Supply in Federal Acquisition Regulation subpart 25.108; or is included in the FAA Nationwide Buy American Waivers Issued list.

The bidder or offeror must complete and submit the certification of compliance with FAA's Buy American Preference, BABA and Made in America laws included herein with their bid or offer. The Airport Sponsor/Owner will reject as nonresponsive any bid or offer that does not include a completed certification of compliance with FAA's Buy American Preference and BABA.

The bidder or offeror certifies that all constructions materials, defined to mean an article, material, or supply other than an item of primarily iron or steel; a manufactured product; cement and cementitious materials; aggregates such as stone, sand, or gravel; or aggregate binding agents or additives that are or consist primarily of: non-ferrous metals; plastic and polymer-based products (including polyvinylchloride, composite building materials, and polymers used in fiber optic cables); glass (including optic glass); lumber; or drywall used in the project are manufactured in the U.S.

¹ Per Executive Order 14005 "Made in America Laws" means all statutes, regulations, rules, and Executive Orders relating to federal financial assistance awards or federal procurement, including those that refer to "Buy America" or "Buy American," that require, or provide a preference for, the purchase or acquisition of goods, products, or materials produced in the United States, including iron, steel, and manufactured products offered in the United States.

A4.3.2 Certification of Compliance with FAA Buy American Preference – Construction Projects

As a matter of bid responsiveness, the bidder or offeror must complete, sign, date, and submit this certification statement with its proposal. The bidder or offeror must indicate how it intends to comply with 49 USC § 50101, BABA and other related Made in America Laws, U.S. statutes, guidance, and FAA policies, by selecting one of the following certification statements. These statements are mutually exclusive. Bidder must select one or the other (i.e., not both) by inserting a checkmark (✓) or the letter “X”.

- Bidder or offeror hereby certifies that it will comply with 49 USC § 50101, BABA and other related U.S. statutes, guidance, and policies of the FAA by:
 - a) Only installing iron, steel and manufactured products produced in the United States;
 - b) Only installing construction materials defined as: an article, material, or supply – other than an item of primarily iron or steel; a manufactured product; cement and cementitious materials; aggregates such as stone, sand, or gravel; or aggregate binding agents or additives that are or consist primarily of non-ferrous metals; plastic and polymer-based products (including polyvinylchloride, composite building materials, and polymers used in fiber optic cables); glass (including optic glass); lumber or drywall that have been manufactured in the United States.
 - c) Installing manufactured products for which the Federal Aviation Administration (FAA) has issued a waiver as indicated by inclusion on the current FAA Nationwide Buy American Waivers Issued listing; or
 - d) Installing products listed as an Excepted Article, Material or Supply in Federal Acquisition Regulation Subpart 25.108.

By selecting this certification statement, the bidder or offeror agrees:

- a) To provide to the Airport Sponsor or the FAA evidence that documents the source and origin of the iron, steel, and/or manufactured product.
 - b) To faithfully comply with providing U.S. domestic products.
 - c) To refrain from seeking a waiver request after establishment of the contract, unless extenuating circumstances emerge that the FAA determines justified.
 - d) Certify that all construction materials used in the project are manufactured in the U.S.

- The bidder or offeror hereby certifies it cannot comply with the 100 percent Buy American Preferences of 49 USC § 50101(a) but may qualify for a Type 3 or Type 4 waiver under 49 USC § 50101(b). By selecting this certification statement, the apparent bidder or offeror with the apparent low bid agrees:
 - a) To submit to the Airport Sponsor or FAA within 15 calendar days of being selected as the responsive bidder, a formal waiver request and required documentation that supports the type of waiver being requested.
 - b) That failure to submit the required documentation within the specified timeframe is cause for a non-responsive determination that may result in rejection of the proposal.
 - c) To faithfully comply with providing U.S. domestic products at or above the approved U.S. domestic content percentage as approved by the FAA.
 - d) To furnish U.S. domestic product for any waiver request that the FAA rejects.
 - e) To refrain from seeking a waiver request after establishment of the contract, unless extenuating circumstances emerge that the FAA determines justified.

Required Documentation

Type 2 Waiver (Nonavailability) - The iron, steel, manufactured goods or construction materials or manufactured goods are not available in sufficient quantity or quality in the United States. The required documentation for the Nonavailability waiver is

- a) Completed Content Percentage Worksheet and Final Assembly Questionnaire
- b) Record of thorough market research, consideration where appropriate of qualifying alternate items, products, or materials including;
- c) A description of the market research activities and methods used to identify domestically manufactured items capable of satisfying the requirement, including the timing of the research and conclusions reached on the availability of sources.

Type 3 Waiver – The cost of components and subcomponents produced in the United States is more than 60 percent of the cost of all components and subcomponents of the “facility/project.” The required documentation for a Type 3 waiver is:

- a) Completed Content Percentage Worksheet and Final Assembly Questionnaire including;
- b) Listing of all manufactured products that are not comprised of 100 percent U.S. domestic content (excludes products listed on the FAA Nationwide Buy American Waivers Issued listing and products excluded by Federal Acquisition Regulation Subpart 25.108; products of unknown origin must be considered as non-domestic products in their entirety).
- c) Cost of non-domestic components and subcomponents, excluding labor costs associated with final assembly and installation at project location.
- d) Percentage of non-domestic component and subcomponent cost as compared to total “facility” component and subcomponent costs, excluding labor costs associated with final assembly and installation at project location.

Type 4 Waiver (Unreasonable Costs) - Applying this provision for iron, steel, manufactured goods or construction materials would increase the cost of the overall project by more than 25 percent. The required documentation for this waiver is:

- a) A completed Content Percentage Worksheet and Final Assembly Questionnaire from
- b) At minimum two comparable equal bids and/or offers;
- c) Receipt or record that demonstrates that supplier scouting called for in Executive Order 14005, indicates that no domestic source exists for the project and/or component;
- d) Completed waiver applications for each comparable bid and/or offer.

False Statements: Per 49 USC § 47126, this certification concerns a matter within the jurisdiction of the Federal Aviation Administration and the making of a false, fictitious, or fraudulent certification may render the maker subject to prosecution under Title 18, United States Code.

Date

Signature

Company Name

Title

A5 CIVIL RIGHTS - GENERAL

(References: 49 USC § 47123)

In all its activities within the scope of its airport program, the Contractor agrees to comply with pertinent statutes, Executive Orders, and such rules as identified in Title VI List of Pertinent Nondiscrimination Acts and Authorities to ensure that no person shall, on the grounds of race, color, national origin (including limited English proficiency), creed, sex (including sexual orientation and gender identity), age, or disability be excluded from participating in any activity conducted with or benefiting from Federal assistance.

This provision is in addition to that required by Title VI of the Civil Rights Act of 1964.

The above provision binds the Contractor and subcontractors from the bid solicitation period through the completion of the contract.

A6 CIVIL RIGHTS – TITLE VI ASSURANCE
(References: 49 USC § 47123, FAA Order 1400.11)

The Owner, in accordance with the provisions of Title VI of the Civil Rights Act of 1964 (78 Stat. 252, 42 USC §§ 2000d to 2000d-4) and the Regulations, hereby notifies all bidders or offerors that it will affirmatively ensure that for any contract entered into pursuant to this advertisement, [select businesses, or disadvantaged business enterprises or airport concession disadvantaged business enterprises] will be afforded full and fair opportunity to submit bids in response to this invitation and no businesses will be discriminated against on the grounds of race, color, national origin (including limited English proficiency), creed, sex (including sexual orientation and gender identity), age, or disability in consideration for an award.

Title VI List of Pertinent Nondiscrimination Acts and Authorities

During the performance of this contract, the Contractor, for itself, its assignees, and successors in interest (hereinafter referred to as the “Contractor”) agrees to comply with the following non-discrimination statutes and authorities; including but not limited to:

- Title VI of the Civil Rights Act of 1964 (42 USC § 2000d *et seq.*, 78 stat. 252) (prohibits discrimination on the basis of race, color, national origin);
- 49 CFR part 21 (Non-discrimination in Federally-Assisted programs of the Department of Transportation—Effectuation of Title VI of the Civil Rights Act of 1964);
- The Uniform Relocation Assistance and Real Property Acquisition Policies Act of 1970, (42 USC § 4601) (prohibits unfair treatment of persons displaced or whose property has been acquired because of Federal or Federal-aid programs and projects);
- Section 504 of the Rehabilitation Act of 1973 (29 USC § 794 *et seq.*), as amended (prohibits discrimination on the basis of disability); and 49 CFR part 27 (Nondiscrimination on the Basis of Disability in Programs or Activities Receiving Federal Financial Assistance);
- The Age Discrimination Act of 1975, as amended (42 USC § 6101 *et seq.*) (prohibits discrimination on the basis of age);
- Airport and Airway Improvement Act of 1982 (49 USC § 47123), as amended (prohibits discrimination based on race, creed, color, national origin, or sex);
- The Civil Rights Restoration Act of 1987 (PL 100-259) (broadened the scope, coverage and applicability of Title VI of the Civil Rights Act of 1964, the Age Discrimination Act of 1975 and Section 504 of the Rehabilitation Act of 1973, by expanding the definition of the terms “programs or activities” to include all of the programs or activities of the Federal-aid recipients, sub-recipients and contractors, whether such programs or activities are Federally funded or not);
- Titles II and III of the Americans with Disabilities Act of 1990 (42 USC § 12101, *et seq.*) (prohibit discrimination on the basis of disability in the operation of public entities, public and private transportation systems, places of public accommodation, and certain testing entities) as implemented by U.S. Department of Transportation regulations at 49 CFR parts 37 and 38;
- The Federal Aviation Administration’s Nondiscrimination statute (49 USC § 47123) (prohibits discrimination on the basis of race, color, national origin, and sex);
- Executive Order 12898, Federal Actions to Address Environmental Justice in Minority Populations and Low-Income Populations (ensures nondiscrimination against minority populations by discouraging programs, policies, and activities with disproportionately high and adverse human health or environmental effects on minority and low-income populations);
- Executive Order 13166, Improving Access to Services for Persons with Limited English Proficiency, and resulting agency guidance, national origin discrimination includes discrimination because of limited English proficiency (LEP). To ensure compliance with Title VI, you must take

reasonable steps to ensure that LEP persons have meaningful access to your programs [70 Fed. Reg. 74087 (2005)];

- Title IX of the Education Amendments of 1972, as amended, which prohibits you from discriminating because of sex in education programs or activities (20 USC § 1681, et seq).

Compliance with Nondiscrimination Requirements:

During the performance of this contract, the Contractor, for itself, its assignees, and successors in interest (hereinafter referred to as the “Contractor”), agrees as follows:

- 1. Compliance with Regulations:** The Contractor (hereinafter includes consultants) will comply with the Title VI List of Pertinent Nondiscrimination Acts and Authorities, as they may be amended from time to time, which are herein incorporated by reference and made a part of this contract.
- 2. Nondiscrimination:** The Contractor, with regard to the work performed by it during the contract, will not discriminate on the grounds of race, color, national origin (including limited English proficiency), creed, sex (including sexual orientation and gender identity), age, or disability in the selection and retention of subcontractors, including procurements of materials and leases of equipment. The Contractor will not participate directly or indirectly in the discrimination prohibited by the Nondiscrimination Acts and Authorities, including employment practices when the contract covers any activity, project, or program set forth in Appendix B of 49 CFR part 21.
- 3. Solicitations for Subcontracts, including Procurements of Materials and Equipment:** In all solicitations, either by competitive bidding or negotiation made by the Contractor for work to be performed under a subcontract, including procurements of materials, or leases of equipment, each potential subcontractor or supplier will be notified by the Contractor of the contractor’s obligations under this contract and the Nondiscrimination Acts and Authorities on the grounds of race, color, or national origin.
- 4. Information and Reports:** The Contractor will provide all information and reports required by the Acts, the Regulations, and directives issued pursuant thereto and will permit access to its books, records, accounts, other sources of information, and its facilities as may be determined by the Sponsor or the Federal Aviation Administration to be pertinent to ascertain compliance with such Nondiscrimination Acts and Authorities and instructions. Where any information required of a contractor is in the exclusive possession of another who fails or refuses to furnish the information, the Contractor will so certify to the Sponsor or the Federal Aviation Administration, as appropriate, and will set forth what efforts it has made to obtain the information.
- 5. Sanctions for Noncompliance:** In the event of a Contractor’s noncompliance with the non-discrimination provisions of this contract, the Sponsor will impose such contract sanctions as it or the Federal Aviation Administration may determine to be appropriate, including, but not limited to:
 - a. Withholding payments to the Contractor under the contract until the Contractor complies; and/or
 - b. Cancelling, terminating, or suspending a contract, in whole or in part.
- 6. Incorporation of Provisions:** The Contractor will include the provisions of paragraphs one through six in every subcontract, including procurements of materials and leases of equipment, unless exempt by the Acts, the Regulations, and directives issued pursuant thereto. The Contractor will take action with respect to any subcontract or procurement as the Sponsor or the Federal Aviation Administration may direct as a means of enforcing such provisions including sanctions for noncompliance. Provided, that if the Contractor becomes involved in, or is threatened with litigation by a subcontractor, or supplier because of such direction, the Contractor may request the Sponsor to enter into any litigation to protect the interests of the Sponsor. In addition, the Contractor may request the United States to enter into the litigation to protect the interests of the United States.

A7 CLEAN AIR AND WATER POLLUTION CONTROL

(References: 2 CFR Part 200, Appendix II(G), 42 USC § 7401, et seq, 33 USC § 1251, et seq)

Contractor agrees to comply with all applicable standards, orders, and regulations issued pursuant to the Clean Air Act (42 USC §§ 7401-7671q) and the Federal Water Pollution Control Act as amended (33 USC §§ 1251-1387). The Contractor agrees to report any violation to the Owner immediately upon discovery. The Owner assumes responsibility for notifying the Environmental Protection Agency (EPA) and the Federal Aviation Administration.

Contractor must include this requirement in all subcontracts that exceed \$150,000.

A8 CONTRACT WORKHOURS AND SAFETY STANDARDS ACT REQUIREMENTS

(References: 2 CFR Part 200, Appendix II(E), 2 CFR § 5.5(b), 40 USC § 3702, 40 USC § 3704)

CONTRACT WORKHOURS AND SAFETY STANDARDS ACT REQUIREMENTS

1. Overtime Requirements.

No contractor or subcontractor contracting for any part of the contract work which may require or involve the employment of laborers or mechanics shall require or permit any such laborer or mechanic, including watchmen and guards, in any workweek in which he or she is employed on such work to work in excess of forty hours in such workweek unless such laborer or mechanic receives compensation at a rate not less than one and one-half times the basic rate of pay for all hours worked in excess of forty hours in such workweek.

2. Violation; Liability for Unpaid Wages; Liquidated Damages.

In the event of any violation of the clause set forth in paragraph (1) of this clause, the Contractor and any subcontractor responsible therefor shall be liable for the unpaid wages. In addition, such contractor and subcontractor shall be liable to the United States (in the case of work done under contract for the District of Columbia or a territory, to such District or to such territory), for liquidated damages. Such liquidated damages shall be computed with respect to each individual laborer or mechanic, including watchmen and guards, employed in violation of the clause set forth in paragraph (1) of this clause, in the sum of \$29 for each calendar day on which such individual was required or permitted to work in excess of the standard workweek of forty hours without payment of the overtime wages required by the clause set forth in paragraph (1) of this clause.

3. Withholding for Unpaid Wages and Liquidated Damages.

The Federal Aviation Administration (FAA) or the Owner shall upon its own action or upon written request of an authorized representative of the Department of Labor withhold or cause to be withheld, from any moneys payable on account of work performed by the contractor or subcontractor under any such contract or any other Federal contract with the same prime contractor, or any other federally-assisted contract subject to the Contract Work Hours and Safety Standards Act, which is held by the same prime contractor, such sums as may be determined to be necessary to satisfy any liabilities of such contractor or subcontractor for unpaid wages and liquidated damages as provided in the clause set forth in paragraph (2) of this clause.

4. Subcontractors.

The Contractor or subcontractor shall insert in any subcontracts the clauses set forth in paragraphs (1) through (4) and also a clause requiring the subcontractor to include these clauses in any lower tier subcontracts. The prime contractor shall be responsible for compliance by any subcontractor or lower tier subcontractor with the clauses set forth in paragraphs (1) through (4) of this clause.

A9 COPELAND “ANTI-KICKBACK” ACT

(References: 2 CFR Part 200, Appendix II(D), 29 CFR Parts 3 and 5)

Contractor must comply with the requirements of the Copeland “Anti-Kickback” Act (18 USC 874 and 40 USC 3145), as supplemented by Department of Labor regulation 29 CFR part 3. Contractor and subcontractors are prohibited from inducing, by any means, any person employed on the project to give up any part of the compensation to which the employee is entitled. The Contractor and each Subcontractor must submit to the Owner, a weekly statement on the wages paid to each employee performing on covered work during the prior week. Owner must report any violations of the Act to the Federal Aviation Administration.

A10 DAVIS-BACON REQUIREMENTS

(References: 2 CFR Part 200, Appendix II(D), 29 CFR Part 5, 49 USC § 47112(b), 40 USC §§ 3141-3144, 3146, and 3147)

DAVIS-BACON REQUIREMENTS

1. Minimum Wages.

(i) All laborers and mechanics employed or working upon the site of the work will be paid unconditionally and not less often than once a week, and without subsequent deduction or rebate on any account (except such payroll deductions as are permitted by the Secretary of Labor under the Copeland Act (29 CFR Part 3)), the full amount of wages and bona fide fringe benefits (or cash equivalent thereof) due at time of payment computed at rates not less than those contained in the wage determination of the Secretary of Labor which is attached hereto and made a part hereof, regardless of any contractual relationship which may be alleged to exist between the Contractor and such laborers and mechanics.

Contributions made or costs reasonably anticipated for bona fide fringe benefits under section 1(b)(2) of the Davis-Bacon Act on behalf of laborers or mechanics are considered wages paid to such laborers or mechanics, subject to the provisions of paragraph (1)(iv) of this section; also, regular contributions made or costs incurred for more than a weekly period (but not less often than quarterly) under plans, funds, or programs which cover the particular weekly period, are deemed to be constructively made or incurred during such weekly period. Such laborers and mechanics shall be paid the appropriate wage rate and fringe benefits on the wage determination for the classification of work actually performed, without regard to skill, except as provided in 29 CFR § 5.5(a)(4). Laborers or mechanics performing work in more than one classification may be compensated at the rate specified for each classification for the time actually worked therein: *Provided*, that the employer's payroll records accurately set forth the time spent in each classification in which work is performed. The wage determination (including any additional classification and wage rates conformed under (1)(ii) of this section) and the Davis-Bacon poster (WH-1321) shall be posted at all times by the Contractor and its subcontractors at the site of the work in a prominent and accessible place where it can easily be seen by the workers.

(ii)(A) The contracting officer shall require that any class of laborers or mechanics, including helpers, which is not listed in the wage determination and which is to be employed under the contract shall be classified in conformance with the wage determination. The contracting officer shall approve an additional classification and wage rate and fringe benefits therefore only when the following criteria have been met:

- (1) The work to be performed by the classification requested is not performed by a classification in the wage determination;
- (2) The classification is utilized in the area by the construction industry; and
- (3) The proposed wage rate, including any bona fide fringe benefits, bears a reasonable relationship to the wage rates contained in the wage determination.

(B) If the Contractor and the laborers and mechanics to be employed in the classification (if known), or their representatives, and the contracting officer agree on the classification and wage rate (including the amount designated for fringe benefits where appropriate), a report of the action taken shall be sent by the contracting officer to the Administrator of the Wage and Hour Division, U.S. Department of Labor, Washington, DC 20210. The Administrator, or an authorized representative, will approve, modify, or disapprove every additional classification action within 30 days of receipt and so advise the contracting officer or will notify the contracting officer within the 30-day period that additional time is necessary.

(C) In the event the Contractor, the laborers, or mechanics to be employed in the classification, or their representatives, and the contracting officer do not agree on the proposed classification and wage rate

(including the amount designated for fringe benefits, where appropriate), the contracting officer shall refer the questions, including the views of all interested parties and the recommendation of the contracting officer, to the Administrator for determination. The Administrator, or an authorized representative, will issue a determination within 30 days of receipt and so advise the contracting officer or will notify the contracting officer within the 30-day period that additional time is necessary.

(D) The wage rate (including fringe benefits where appropriate) determined pursuant to subparagraphs (1)(ii) (B) or (C) of this paragraph, shall be paid to all workers performing work in the classification under this contract from the first day on which work is performed in the classification.

(iii) Whenever the minimum wage rate prescribed in the contract for a class of laborers or mechanics includes a fringe benefit which is not expressed as an hourly rate, the contractor shall either pay the benefit as stated in the wage determination or shall pay another bona fide fringe benefit or an hourly cash equivalent thereof.

(iv) If the Contractor does not make payments to a trustee or other third person, the Contractor may consider as part of the wages of any laborer or mechanic the amount of any costs reasonably anticipated in providing bona fide fringe benefits under a plan or program, *Provided*, that the Secretary of Labor has found, upon the written request of the Contractor, that the applicable standards of the Davis-Bacon Act have been met. The Secretary of Labor may require the Contractor to set aside in a separate account assets for the meeting of obligations under the plan or program.

2. Withholding.

The Federal Aviation Administration or the Sponsor shall upon its own action or upon written request of an authorized representative of the Department of Labor withhold or cause to be withheld from the Contractor under this contract or any other Federal contract with the same prime contractor, or any other federally-assisted contract subject to Davis-Bacon prevailing wage requirements, which is held by the same prime contractor, so much of the accrued payments or advances as may be considered necessary to pay laborers and mechanics, including apprentices, trainees, and helpers, employed by the Contractor or any subcontractor the full amount of wages required by the contract. In the event of failure to pay any laborer or mechanic, including any apprentice, trainee, or helper, employed or working on the site of the work, all or part of the wages required by the contract, the Federal Aviation Administration may, after written notice to the Contractor, Sponsor, Applicant, or Owner, take such action as may be necessary to cause the suspension of any further payment, advance, or guarantee of funds until such violations have ceased.

3. Payrolls and Basic Records.

(i) Payrolls and basic records relating thereto shall be maintained by the Contractor during the course of the work and preserved for a period of three years thereafter for all laborers and mechanics working at the site of the work. Such records shall contain the name, address, and social security number of each such worker; his or her correct classification; hourly rates of wages paid (including rates of contributions or costs anticipated for bona fide fringe benefits or cash equivalents thereof of the types described in 1(b)(2)(B) of the Davis-Bacon Act); daily and weekly number of hours worked; deductions made; and actual wages paid. Whenever the Secretary of Labor has found under 29 CFR 5.5(a)(1)(iv) that the wages of any laborer or mechanic include the amount of any costs reasonably anticipated in providing benefits under a plan or program described in section 1(b)(2)(B) of the Davis-Bacon Act, the Contractor shall maintain records that show that the commitment to provide such benefits is enforceable, that the plan or program is financially responsible, and that the plan or program has been communicated in writing to the laborers or mechanics affected, and records which show the costs anticipated or the actual costs incurred in providing such benefits. Contractors employing apprentices or trainees under approved programs shall maintain written evidence of the registration of apprenticeship programs and certification of trainee programs, the registration of the apprentices and trainees, and the ratios and wage rates prescribed in the applicable programs.

(ii)(A) The Contractor shall submit weekly for each week in which any contract work is performed a copy of all payrolls to the Federal Aviation Administration if the agency is a party to the contract, but if the agency is not such a party, the Contractor will submit the payrolls to the applicant, Sponsor, or Owner, as the case may be, for transmission to the Federal Aviation Administration. The payrolls submitted shall set out accurately and completely all of the information required to be maintained under 29 CFR § 5.5(a)(3)(i), except that full social security numbers and home addresses shall not be included on weekly transmittals. Instead the payrolls shall only need to include an individually identifying number for each employee (*e.g.*, the last four digits of the employee's social security number). The required weekly payroll information may be submitted in any form desired. Optional Form WH-347 is available for this purpose from the Wage and Hour Division Web site at <http://www.dol.gov/esa/whd/forms/wh347instr.htm> or its successor site. The prime contractor is responsible for the submission of copies of payrolls by all subcontractors. Contractors and subcontractors shall maintain the full social security number and current address of each covered worker and shall provide them upon request to the Federal Aviation Administration if the agency is a party to the contract, but if the agency is not such a party, the Contractor will submit them to the applicant, Sponsor, or Owner, as the case may be, for transmission to the Federal Aviation Administration, the Contractor, or the Wage and Hour Division of the Department of Labor for purposes of an investigation or audit of compliance with prevailing wage requirements. It is not a violation of this section for a prime contractor to require a subcontractor to provide addresses and social security numbers to the prime contractor for its own records, without weekly submission to the sponsoring government agency (or the applicant, Sponsor, or Owner).

(B) Each payroll submitted shall be accompanied by a "Statement of Compliance," signed by the Contractor or subcontractor or his or her agent who pays or supervises the payment of the persons employed under the contract and shall certify the following:

- (1) That the payroll for the payroll period contains the information required to be provided under 29 CFR § 5.5(a)(3)(ii), the appropriate information is being maintained under 29 CFR § 5.5(a)(3)(i), and that such information is correct and complete;
- (2) That each laborer and mechanic (including each helper, apprentice, and trainee) employed on the contract during the payroll period has been paid the full weekly wages earned, without rebate, either directly or indirectly, and that no deductions have been made either directly or indirectly from the full wages earned, other than permissible deductions as set forth in Regulations, 29 CFR Part 3; (3) That each laborer or mechanic has been paid not less than the applicable wage rates and fringe benefits or cash equivalents for the classification of work performed, as specified in the applicable wage determination incorporated into the contract.

(C) The weekly submission of a properly executed certification set forth on the reverse side of Optional Form WH-347 shall satisfy the requirement for submission of the "Statement of Compliance" required by paragraph (3)(ii)(B) of this section.

(D) The falsification of any of the above certifications may subject the Contractor or subcontractor to civil or criminal prosecution under Section 1001 of Title 18 and Section 231 of Title 31 of the United States Code.

(iii) The Contractor or subcontractor shall make the records required under paragraph (3)(i) of this section available for inspection, copying, or transcription by authorized representatives of the Sponsor, the Federal Aviation Administration, or the Department of Labor and shall permit such representatives to interview employees during working hours on the job. If the Contractor or subcontractor fails to submit the required records or to make them available, the Federal agency may, after written notice to the Contractor, Sponsor, applicant, or Owner, take such action as may be necessary to cause the suspension of any further payment,

advance, or guarantee of funds. Furthermore, failure to submit the required records upon request or to make such records available may be grounds for debarment action pursuant to 29 CFR § 5.12.

4. Apprentices and Trainees.

(i) Apprentices. Apprentices will be permitted to work at less than the predetermined rate for the work they performed when they are employed pursuant to and individually registered in a bona fide apprenticeship program registered with the U.S. Department of Labor, Employment and Training Administration, Office of Apprenticeship Training, Employer and Labor Services, or with a State Apprenticeship Agency recognized by the Office, or if a person is employed in his or her first 90 days of probationary employment as an apprentice in such an apprenticeship program, who is not individually registered in the program, but who has been certified by the Office of Apprenticeship Training, Employer and Labor Services or a State Apprenticeship Agency (where appropriate) to be eligible for probationary employment as an apprentice. The allowable ratio of apprentices to journeymen on the job site in any craft classification shall not be greater than the ratio permitted to the contractor as to the entire work force under the registered program. Any worker listed on a payroll at an apprentice wage rate, who is not registered or otherwise employed as stated above, shall be paid not less than the applicable wage rate on the wage determination for the classification of work actually performed. In addition, any apprentice performing work on the job site in excess of the ratio permitted under the registered program shall be paid not less than the applicable wage rate on the wage determination for the work actually performed. Where a contractor is performing construction on a project in a locality other than that in which its program is registered, the ratios and wage rates (expressed in percentages of the journeyman's hourly rate) specified in the Contractor's or subcontractor's registered program shall be observed. Every apprentice must be paid at not less than the rate specified in the registered program for the apprentice's level of progress, expressed as a percentage of the journeymen hourly rate specified in the applicable wage determination. Apprentices shall be paid fringe benefits in accordance with the provisions of the apprenticeship program. If the apprenticeship program does not specify fringe benefits, apprentices must be paid the full amount of fringe benefits listed on the wage determination for the applicable classification. If the Administrator determines that a different practice prevails for the applicable apprentice classification, fringes shall be paid in accordance with that determination. In the event the Office of Apprenticeship Training, Employer and Labor Services, or a State Apprenticeship Agency recognized by the Office, withdraws approval of an apprenticeship program, the Contractor will no longer be permitted to utilize apprentices at less than the applicable predetermined rate for the work performed until an acceptable program is approved.

(ii) Trainees. Except as provided in 29 CFR § 5.16, trainees will not be permitted to work at less than the predetermined rate for the work performed unless they are employed pursuant to and individually registered in a program which has received prior approval, evidenced by formal certification by the U.S. Department of Labor, Employment and Training Administration. The ratio of trainees to journeymen on the job site shall not be greater than permitted under the plan approved by the Employment and Training Administration. Every trainee must be paid at not less than the rate specified in the approved program for the trainee's level of progress, expressed as a percentage of the journeyman hourly rate specified in the applicable wage determination. Trainees shall be paid fringe benefits in accordance with the provisions of the trainee program. If the trainee program does not mention fringe benefits, trainees shall be paid the full amount of fringe benefits listed on the wage determination unless the Administrator of the Wage and Hour Division determines that there is an apprenticeship program associated with the corresponding journeyman wage rate on the wage determination that provides for less than full fringe benefits for apprentices. Any employee listed on the payroll at a trainee rate that is not registered and participating in a training plan approved by the Employment and Training Administration shall be paid not less than the applicable wage rate on the wage determination for the classification of work actually performed. In addition, any trainee performing work on the job site in excess of the ratio permitted under the registered program shall be paid not less than the applicable wage rate on the wage determination for the work actually performed. In the event the Employment and Training Administration withdraws approval of a training program, the

Contractor will no longer be permitted to utilize trainees at less than the applicable predetermined rate for the work performed until an acceptable program is approved.

(iii) Equal Employment Opportunity. The utilization of apprentices, trainees, and journeymen under this part shall be in conformity with the equal employment opportunity requirements of Executive Order 11246, as amended, and 29 CFR Part 30.

5. Compliance with Copeland Act Requirements.

The Contractor shall comply with the requirements of 29 CFR Part 3, which are incorporated by reference in this contract.

6. Subcontracts.

The Contractor or subcontractor shall insert in any subcontracts the clauses contained in 29 CFR §§ 5.5(a)(1) through (10) and such other clauses as the Federal Aviation Administration may by appropriate instructions require, and also a clause requiring the subcontractors to include these clauses in any lower tier subcontracts. The prime contractor shall be responsible for the compliance by any subcontractor or lower tier subcontractor with all the contract clauses in 29 CFR § 5.5.

7. Contract Termination: Debarment.

A breach of the contract clauses in paragraph 1 through 10 of this section may be grounds for termination of the contract, and for debarment as a contractor and a subcontractor as provided in 29 CFR § 5.12.

8. Compliance with Davis-Bacon and Related Act Requirements.

All rulings and interpretations of the Davis-Bacon and Related Acts contained in 29 CFR Parts 1, 3, and 5 are herein incorporated by reference in this contract.

9. Disputes Concerning Labor Standards.

Disputes arising out of the labor standards provisions of this contract shall not be subject to the general disputes clause of this contract. Such disputes shall be resolved in accordance with the procedures of the Department of Labor set forth in 29 CFR Parts 5, 6, and 7. Disputes within the meaning of this clause include disputes between the Contractor (or any of its subcontractors) and the contracting agency, the U.S. Department of Labor, or the employees or their representatives.

10. Certification of Eligibility.

(i) By entering into this contract, the Contractor certifies that neither it (nor he or she) nor any person or firm who has an interest in the Contractor's firm is a person or firm ineligible to be awarded Government contracts by virtue of section 3(a) of the Davis-Bacon Act or 29 CFR § 5.12(a)(1).

(ii) No part of this contract shall be subcontracted to any person or firm ineligible for award of a Government contract by virtue of section 3(a) of the Davis-Bacon Act or 29 CFR § 5.12(a)(1).

(iii) The penalty for making false statements is prescribed in the U.S. Criminal Code, 18 USC § 1001.

A11 DEBARMENT AND SUSPENSION

(References: 2 CFR Part 180 (Subpart B), 2 CFR Part 200, Appendix II(H), 2 CFR Part 1200, DOT Order 4200.5, Executive Orders 12549 and 12689)

CERTIFICATION OF OFFEROR/BIDDER REGARDING DEBARMENT

By submitting a bid/proposal under this solicitation, the bidder or offeror certifies that neither it nor its principals are presently debarred or suspended by any Federal department or agency from participation in this transaction.

CERTIFICATION OF LOWER TIER CONTRACTORS REGARDING DEBARMENT

The successful bidder, by administering each lower tier subcontract that exceeds \$25,000 as a “covered transaction”, must confirm each lower tier participant of a “covered transaction” under the project is not presently debarred or otherwise disqualified from participation in this federally-assisted project. The successful bidder will accomplish this by:

1. Checking the System for Award Management at website: <http://www.sam.gov>.
2. Collecting a certification statement similar to the Certification of Offeror /Bidder Regarding Debarment, above.
3. Inserting a clause or condition in the covered transaction with the lower tier contract.

If the Federal Aviation Administration later determines that a lower tier participant failed to disclose to a higher tier participant that it was excluded or disqualified at the time it entered the covered transaction, the FAA may pursue any available remedies, including suspension and debarment of the non-compliant participant.

A12 DISADVANTAGED BUSINESS ENTERPRISE

(References: 49 CFR Part 26)

Bid Information Submitted as a matter of **responsiveness**:

The Owner's award of this contract is conditioned upon Bidder or Offeror satisfying the good faith effort requirements of 49 CFR § 26.53.

As a condition of responsiveness, the Bidder or Offeror must submit the following information with its proposal on the forms provided herein:

- 1) The names and addresses of Disadvantaged Business Enterprise (DBE) firms that will participate in the contract;
- 2) A description of the work that each DBE firm will perform;
- 3) The dollar amount of the participation of each DBE firm listed under (1);
- 4) Written statement from Bidder or Offeror that attests their commitment to use the DBE firm(s) listed under (1) to meet the Owner's project goal
- 5) Written confirmation from each listed DBE firm that it is participating in the contract in the kind and amount of work provided in the prime contractor's commitment; and
- 6) If Bidder or Offeror cannot meet the advertised project DBE goal, evidence of good faith efforts undertaken by the Bidder or Offeror as described in appendix A to 49 CFR part 26. The documentation of good faith efforts must include copies of each DBE and non-DBE subcontractor quote submitted to the bidder when a non-DBE subcontractor was selected over a DBE for work on the contract.

Bid Information submitted as a matter of **responsibility**:

The Owner's award of this contract is conditioned upon Bidder or Offeror satisfying the good faith effort requirements of 49 CFR § 26.53.

As a condition of responsibility, every Bidder or Offeror must submit the following information on the forms provided herein within five days after bid opening.

- 1) The names and addresses of Disadvantaged Business Enterprise (DBE) firms that will participate in the contract;
- 2) A description of the work that each DBE firm will perform;
- 3) The dollar amount of the participation of each DBE firm listed under (1);
- 4) Written statement from Bidder or Offeror that attests their commitment to use the DBE firm(s) listed under (1) to meet the Owner's project goal;
- 5) Written confirmation from each listed DBE firm that it is participating in the contract in the kind and amount of work provided in the prime contractor's commitment; and
- 6) If Bidder or Offeror cannot meet the advertised project DBE goal, evidence of good faith efforts undertaken by the Bidder or Offeror as described in appendix A to 49 CFR part 26. The documentation of good faith efforts must include copies of each DBE and non-DBE subcontractor quote submitted to the bidder when a non-DBE subcontractor was selected over a DBE for work on the contract.

The requirements of 49 CFR part 26 apply to this contract. It is the policy of the Owner to practice nondiscrimination based on race, color, sex, or national origin in the award or performance of this contract. The Owner encourages participation by all firms qualifying under this solicitation regardless of business size or ownership.

Contract Assurance (49 CFR § 26.13)

The Contractor, subrecipient or subcontractor shall not discriminate on the basis of race, color, national origin, or sex in the performance of this contract. The Contractor shall carry out applicable requirements of 49 CFR part 26 in the award and administration of DOT-assisted contracts. Failure by the Contractor to carry out these requirements is a material breach of this contract, which may result in the termination of this contract or such other remedy as the recipient deems appropriate, which may include, but is not limited to:

- a) Withholding monthly progress payments;
- b) Assessing sanctions;
- c) Liquidated damages; and/or
- d) Disqualifying the Contractor from future bidding as non-responsible.

Prompt Payment (49 CFR § 26.29)

The prime contractor agrees to pay each subcontractor under this prime contract for satisfactory performance of its contract no later than 30 days from the receipt of each payment the prime contractor receives from Owner. The prime contractor agrees further to return retainage payments to each subcontractor within 30 days after the subcontractor's work is satisfactorily completed. Any delay or postponement of payment from the above referenced time frame may occur only for good cause following written approval of the Owner. **This clause applies to both DBE and non-DBE subcontractors.**

Termination of DBE Subcontracts (49 CFR § 26.53(f))

The prime contractor must not terminate a DBE subcontractor listed in response to A12 bid responsiveness or bid responsibility requirements (or an approved substitute DBE firm) without prior written consent of Owner. This includes, but is not limited to, instances in which the prime contractor seeks to perform work originally designated for a DBE subcontractor with its own forces or those of an affiliate, a non-DBE firm, or with another DBE firm.

The prime contractor shall utilize the specific DBEs listed to perform the work and supply the materials for which each is listed unless the contractor obtains written consent [Name of Recipient]. Unless [Name of Recipient] consent is provided, the prime contractor shall not be entitled to any payment for work or material unless it is performed or supplied by the listed DBE.

The Owner may provide such written consent only if the Owner agrees, for reasons stated in the concurrence document, that the prime contractor has good cause to terminate the DBE firm. For purposes of this paragraph, good cause includes the circumstances listed in 49 CFR §26.53.

Before transmitting to the Owner its request to terminate and/or substitute a DBE subcontractor, the prime contractor must give notice in writing to the DBE subcontractor, with a copy to the Owner, of its intent to request to terminate and/or substitute, and the reason for the request.

The prime contractor must give the DBE five days to respond to the prime contractor's notice and advise the Owner and the contractor of the reasons, if any, why it objects to the proposed termination of its subcontract and why the Owner should not approve the prime contractor's action. If required in a particular case as a matter of public necessity (e.g., safety), the Owner may provide a response period shorter than five days.

In addition to post-award terminations, the provisions of this section apply to preaward deletions of or substitutions for DBE firms put forward by offerors in negotiated procurements.

A13 DISTRACTED DRIVING

(References: Executive Order 13513, DOT Order 3902.10)

TEXTING WHEN DRIVING

In accordance with Executive Order 13513, “Federal Leadership on Reducing Text Messaging While Driving”, (10/1/2009) and DOT Order 3902.10, “Text Messaging While Driving”, (12/30/2009), the Federal Aviation Administration encourages recipients of Federal grant funds to adopt and enforce safety policies that decrease crashes by distracted drivers, including policies to ban text messaging while driving when performing work related to a grant or subgrant.

In support of this initiative, the Owner encourages the Contractor to promote policies and initiatives for its employees and other work personnel that decrease crashes by distracted drivers, including policies that ban text messaging while driving motor vehicles while performing work activities associated with the project. The Contractor must include the substance of this clause in all sub-tier contracts exceeding \$10,000 that involve driving a motor vehicle in performance of work activities associated with the project.

A14 PROHIBITION ON CERTAIN TELECOMMUNICATIONS AND VIDEO SURVEILLANCE SERVICES OR EQUIPMENT

(References: 2 CFR § 200, Appendix II(K), 2 CFR § 200.216)

Contractor and Subcontractor agree to comply with mandatory standards and policies relating to use and procurement of certain telecommunications and video surveillance services or equipment in compliance with the National Defense Authorization Act [Public Law 115-232 § 889(f)(1)].

A15 DRUG FREE WORKPLACE REQUIREMENTS

(References: 49 CFR Part 32, Drug-Free Workplace Act of 1988 (41 USC § 8101-8106, as amended))

The Drug-Free Workplace Act of 1988 requires some Federal contractors and all Federal grantees to agree that they will provide drug-free workplaces as a condition of receiving a contract or grant from a Federal agency. The Act does not apply to contractors, subcontractors, or subgrantees, although the Federal grantees workplace may be where the contractors, subcontractors, or subgrantees are working.

A16 EQUAL EMPLOYMENT OPPORTUNITY (EEO)

(References: 2 CFR Part 200, Appendix II(C), 41 CFR § 60-1.4, 41 CFR § 60-4.3, Executive Order 11246)

EQUAL OPPORTUNITY CLAUSE

During the performance of this contract, the Contractor agrees as follows:

- 1) The Contractor will not discriminate against any employee or applicant for employment because of race, color, religion, sex, sexual orientation, gender identity, or national origin. The Contractor will take affirmative action to ensure that applicants are employed, and that employees are treated during employment, without regard to their race, color, religion, sex, sexual orientation, gender identify, or national origin. Such action shall include, but not be limited to, the following: employment, upgrading, demotion, or transfer; recruitment or recruitment advertising; layoff, or termination; rates of pay or other forms of compensation; and selection for training, including apprenticeship. The Contractor agrees to post in conspicuous places, available to employees and applicants for employment, notices to be provided setting forth the provisions of this nondiscrimination clause.
- 2) The Contractor will, in all solicitations or advertisements for employees placed by or on behalf of the Contractor, state that all qualified applicants will receive consideration for employment without regard to race, color, religion, sex, sexual orientation, gender identity, or national origin.
- 3) The contractor will not discharge or in any other manner discriminate against any employee or applicant for employment because such employee or applicant has inquired about, discussed, or disclosed the compensation of the employee or applicant or another employee or applicant. This provision shall not apply to instances in which an employee who has access to the compensation information of other employees or applicants as a part of such employee's essential job functions discloses the compensation of such other employees or applicants to individuals who do not otherwise have access to such information, unless such disclosure is in response to a formal complaint or charge, in furtherance of an investigation, proceeding, hearing, or action, including an investigation conducted by the employer, or is consistent with the contractor's legal duty to furnish information.
- 4) The Contractor will send to each labor union or representative of workers with which it has a collective bargaining agreement or other contract or understanding, a notice to be provided by the agency contracting officer, advising the labor union or workers' representative of the Contractor's commitments under this section 202 of Executive Order 11246 of September 24, 1965, and shall post copies of the notice in conspicuous places available to employees and applicants for employment.
- 5) The Contractor will comply with all provisions of Executive Order 11246 of September 24, 1965, and of the rules, regulations, and relevant orders of the Secretary of Labor.
- 6) The Contractor will furnish all information and reports required by Executive Order 11246 of September 24, 1965, and by the rules, regulations, and orders of the Secretary of Labor, or pursuant thereto, and will permit access to his books, records, and accounts by the contracting agency and the Secretary of Labor for purposes of investigation to ascertain compliance with such rules, regulations, and orders.
- 7) In the event of the Contractor's noncompliance with the nondiscrimination clauses of this contract or with any such rules, regulations, or orders, this contract may be canceled, terminated, or suspended in whole or in part and the Contractor may be declared ineligible

for further Government contracts in accordance with procedures authorized in Executive Order 11246 of September 24, 1965, and such other sanctions may be imposed and remedies invoked as provided in Executive Order 11246 of September 24, 1965, or by rule, regulation, or order of the Secretary of Labor, or as otherwise provided by law.

- 8) The Contractor will include the provisions of paragraphs (1) through (8) in every subcontract or purchase order unless exempted by rules, regulations, or orders of the Secretary of Labor issued pursuant to section 204 of Executive Order 11246 of September 24, 1965, so that such provisions will be binding upon each subcontractor or vendor. The Contractor will take such action with respect to any subcontract or purchase order as may be directed by the Secretary of Labor as a means of enforcing such provisions, including sanctions for noncompliance: *Provided*, however, that in the event the contractor becomes involved in, or is threatened with, litigation with a subcontractor or vendor as a result of such direction, the Contractor may request the United States to enter into such litigation to protect the interests of the United States.

STANDARD FEDERAL EQUAL EMPLOYMENT OPPORTUNITY CONSTRUCTION CONTRACT SPECIFICATIONS

1. As used in these specifications:
 - a. “Covered area” means the geographical area described in the solicitation from which this contract resulted;
 - b. “Director” means Director, Office of Federal Contract Compliance Programs (OFCCP), U.S. Department of Labor, or any person to whom the Director delegates authority;
 - c. “Employer identification number” means the Federal social security number used on the Employer’s Quarterly Federal Tax Return, U.S. Treasury Department Form 941;
 - d. “Minority” includes:
 - i. Black (all persons having origins in any of the Black African racial groups not of Hispanic origin);
 - ii. Hispanic (all persons of Mexican, Puerto Rican, Cuban, Central or South American, or other Spanish culture or origin, regardless of race);
 - iii. Asian and Pacific Islander (all persons having origins in any of the original peoples of the Far East, Southeast Asia, the Indian Subcontinent, or the Pacific Islands); and
 - iv. American Indian or Alaskan native (all persons having origins in any of the original peoples of North America and maintaining identifiable tribal affiliations through membership and participation or community identification).
2. Whenever the Contractor, or any subcontractor at any tier, subcontracts a portion of the work involving any construction trade, it shall physically include in each subcontract in excess of \$10,000 the provisions of these specifications and the Notice which contains the applicable goals for minority and female participation and which is set forth in the solicitations from which this contract resulted.
3. If the Contractor is participating (pursuant to 41 CFR part 60-4.5) in a Hometown Plan approved by the U.S. Department of Labor in the covered area either individually or through an association, its affirmative action obligations on all work in the Plan area

(including goals and timetables) shall be in accordance with that Plan for those trades which have unions participating in the Plan. Contractors must be able to demonstrate their participation in and compliance with the provisions of any such Hometown Plan. Each contractor or subcontractor participating in an approved plan is individually required to comply with its obligations under the EEO clause and to make a good faith effort to achieve each goal under the Plan in each trade in which it has employees. The overall good faith performance by other contractors or subcontractors toward a goal in an approved Plan does not excuse any covered contractor's or subcontractor's failure to take good faith efforts to achieve the Plan goals and timetables.

4. The Contractor shall implement the specific affirmative action standards provided in paragraphs 7a through 7p of these specifications. The goals set forth in the solicitation from which this contract resulted are expressed as percentages of the total hours of employment and training of minority and female utilization the Contractor should reasonably be able to achieve in each construction trade in which it has employees in the covered area. Covered construction contractors performing construction work in a geographical areas where they do not have a Federal or federally assisted construction contract shall apply the minority and female goals established for the geographical area where the work is being performed. Goals are published periodically in the Federal Register in notice form, and such notices may be obtained from any Office of Federal Contract Compliance Programs office or from Federal procurement contracting officers. The Contractor is expected to make substantially uniform progress in meeting its goals in each craft during the period specified.
5. Neither the provisions of any collective bargaining agreement, nor the failure by a union with whom the Contractor has a collective bargaining agreement, to refer either minorities or women shall excuse the Contractor's obligations under these specifications, Executive Order 11246, or the regulations promulgated pursuant thereto.
6. In order for the nonworking training hours of apprentices and trainees to be counted in meeting the goals, such apprentices and trainees must be employed by the Contractor during the training period, and the Contractor must have made a commitment to employ the apprentices and trainees at the completion of their training, subject to the availability of employment opportunities. Trainees must be trained pursuant to training programs approved by the U.S. Department of Labor.
7. The Contractor shall take specific affirmative actions to ensure equal employment opportunity. The evaluation of the Contractor's compliance with these specifications shall be based upon its effort to achieve maximum results from its actions. The Contractor shall document these efforts fully, and shall implement affirmative action steps at least as extensive as the following:
 - a. Ensure and maintain a working environment free of harassment, intimidation, and coercion at all sites, and in all facilities at which the Contractor's employees are assigned to work. The Contractor, where possible, will assign two or more women to each construction project. The Contractor shall specifically ensure that all foremen, superintendents, and other onsite supervisory personnel are aware of and carry out the Contractor's obligation to maintain such a working environment, with specific attention to minority or female individuals working at such sites or in such facilities.
 - b. Establish and maintain a current list of minority and female recruitment sources, provide written notification to minority and female recruitment sources and to

community organizations when the Contractor or its unions have employment opportunities available, and maintain a record of the organizations' responses.

- c. Maintain a current file of the names, addresses, and telephone numbers of each minority and female off-the-street applicant and minority or female referral from a union, a recruitment source, or community organization and of what action was taken with respect to each such individual. If such individual was sent to the union hiring hall for referral and was not referred back to the Contractor by the union or, if referred, not employed by the Contractor, this shall be documented in the file with the reason therefor, along with whatever additional actions the Contractor may have taken.
- d. Provide immediate written notification to the Director when the union or unions with which the Contractor has a collective bargaining agreement has not referred to the Contractor a minority person or woman sent by the Contractor, or when the Contractor has other information that the union referral process has impeded the Contractor's efforts to meet its obligations.
- e. Develop on-the-job training opportunities and/or participate in training programs for the area which expressly include minorities and women, including upgrading programs and apprenticeship and trainee programs relevant to the Contractor's employment needs, especially those programs funded or approved by the Department of Labor. The Contractor shall provide notice of these programs to the sources compiled under 7b above.
- f. Disseminate the Contractor's EEO policy by providing notice of the policy to unions and training programs and requesting their cooperation in assisting the Contractor in meeting its EEO obligations; by including it in any policy manual and collective bargaining agreement; by publicizing it in the company newspaper, annual report, etc.; by specific review of the policy with all management personnel and with all minority and female employees at least once a year; and by posting the company EEO policy on bulletin boards accessible to all employees at each location where construction work is performed.
- g. Review, at least annually, the company's EEO policy and affirmative action obligations under these specifications with all employees having any responsibility for hiring, assignment, layoff, termination, or other employment decisions including specific review of these items with onsite supervisory personnel such as superintendents, general foremen, etc., prior to the initiation of construction work at any job site. A written record shall be made and maintained identifying the time and place of these meetings, persons attending, subject matter discussed, and disposition of the subject matter.
- h. Disseminate the Contractor's EEO policy externally by including it in any advertising in the news media, specifically including minority and female news media, and providing written notification to and discussing the Contractor's EEO policy with other contractors and subcontractors with whom the Contractor does or anticipates doing business.
- i. Direct its recruitment efforts, both oral and written, to minority, female, and community organizations, to schools with minority and female students and to minority and female recruitment and training organizations serving the Contractor's recruitment area and employment needs. Not later than one month

prior to the date for the acceptance of applications for apprenticeship or other training by any recruitment source, the Contractor shall send written notification to organizations such as the above, describing the openings, screening procedures, and tests to be used in the selection process.

- j. Encourage present minority and female employees to recruit other minority persons and women and, where reasonable, provide after school, summer, and vacation employment to minority and female youth both on the site and in other areas of a contractor's work force.
 - k. Validate all tests and other selection requirements where there is an obligation to do so under 41 CFR part 60-3.
 - l. Conduct, at least annually, an inventory and evaluation at least of all minority and female personnel, for promotional opportunities and encourage these employees to seek or to prepare for, through appropriate training, etc., such opportunities.
 - m. Ensure that seniority practices, job classifications, work assignments, and other personnel practices do not have a discriminatory effect by continually monitoring all personnel and employment related activities to ensure that the EEO policy and the Contractor's obligations under these specifications are being carried out.
 - n. Ensure that all facilities and company activities are nonsegregated except that separate or single-user toilet and necessary changing facilities shall be provided to assure privacy between the sexes.
 - o. Document and maintain a record of all solicitations of offers for subcontracts from minority and female construction contractors and suppliers, including circulation of solicitations to minority and female contractor associations and other business associations.
 - p. Conduct a review, at least annually, of all supervisor's adherence to and performance under the Contractor's EEO policies and affirmative action obligations.
8. Contractors are encouraged to participate in voluntary associations, which assist in fulfilling one or more of their affirmative action obligations (7a through 7p). The efforts of a contractor association, joint contractor-union, contractor-community, or other similar group of which the Contractor is a member and participant may be asserted as fulfilling any one or more of its obligations under 7a through 7p of these specifications provided that the Contractor actively participates in the group, makes every effort to assure that the group has a positive impact on the employment of minorities and women in the industry, ensures that the concrete benefits of the program are reflected in the Contractor's minority and female workforce participation, makes a good faith effort to meet its individual goals and timetables, and can provide access to documentation which demonstrates the effectiveness of actions taken on behalf of the Contractor. The obligation to comply, however, is the Contractor's and failure of such a group to fulfill an obligation shall not be a defense for the Contractor's noncompliance.
9. A single goal for minorities and a separate single goal for women have been established. The Contractor, however, is required to provide equal employment opportunity and to take affirmative action for all minority groups, both male and female, and all women, both minority and non-minority. Consequently, the Contractor may be in violation of the Executive Order if a particular group is employed in a substantially disparate manner (for example, even though the Contractor has achieved its goals for women generally, the

Contractor may be in violation of the Executive Order if a specific minority group of women is underutilized).

10. The Contractor shall not use the goals and timetables or affirmative action standards to discriminate against any person because of race, color, religion, sex, sexual orientation, gender identity, or national origin.
11. The Contractor shall not enter into any subcontract with any person or firm debarred from Government contracts pursuant to Executive Order 11246.
12. The Contractor shall carry out such sanctions and penalties for violation of these specifications and of the Equal Opportunity Clause, including suspension, termination, and cancellation of existing subcontracts as may be imposed or ordered pursuant to Executive Order 11246, as amended, and its implementing regulations, by the Office of Federal Contract Compliance Programs. Any contractor who fails to carry out such sanctions and penalties shall be in violation of these specifications and Executive Order 11246, as amended.
13. The Contractor, in fulfilling its obligations under these specifications, shall implement specific affirmative action steps, at least as extensive as those standards prescribed in paragraph 7 of these specifications, so as to achieve maximum results from its efforts to ensure equal employment opportunity. If the Contractor fails to comply with the requirements of the Executive Order, the implementing regulations, or these specifications, the Director shall proceed in accordance with 41 CFR part 60-4.8.
14. The Contractor shall designate a responsible official to monitor all employment related activity to ensure that the company EEO policy is being carried out, to submit reports relating to the provisions hereof as may be required by the Government, and to keep records. Records shall at least include for each employee, the name, address, telephone numbers, construction trade, union affiliation if any, employee identification number when assigned, social security number, race, sex, status (e.g., mechanic, apprentice, trainee, helper, or laborer), dates of changes in status, hours worked per week in the indicated trade, rate of pay, and locations at which the work was performed. Records shall be maintained in an easily understandable and retrievable form; however, to the degree that existing records satisfy this requirement, contractors shall not be required to maintain separate records.
15. Nothing herein provided shall be construed as a limitation upon the application of other laws which establish different standards of compliance or upon the application of requirements for the hiring of local or other area residents (e.g. those under the Public Works Employment Act of 1977 and the Community Development Block Grant Program).

A17 FEDERAL FAIR LABOR STANDARDS ACT (FEDERAL MINIMUM WAGE)

(References: 29 USC § 201, et seq, 2 CFR § 200.430)

All contracts and subcontracts that result from this solicitation incorporate by reference the provisions of 29 CFR part 201, et seq, the Federal Fair Labor Standards Act (FLSA), with the same force and effect as if given in full text. The FLSA sets minimum wage, overtime pay, recordkeeping, and child labor standards for full and part-time workers.

The *Contractor* has full responsibility to monitor compliance to the referenced statute or regulation. The *Contractor* must address any claims or disputes that arise from this requirement directly with the U.S. Department of Labor – Wage and Hour Division.

A18 LOBBYING AND INFLUENCING FEDERAL EMPLOYEES

(References: 31 USC § 1352 – Byrd Anti-Lobbying Amendment, 2 CFR Part 200, Appendix II(I), 49 CFR Part 20, Appendix A)

CERTIFICATION REGARDING LOBBYING

The Bidder or Offeror certifies by signing and submitting this bid or proposal, to the best of his or her knowledge and belief, that:

1. No Federal appropriated funds have been paid or will be paid, by or on behalf of the Bidder or Offeror, to any person for influencing or attempting to influence an officer or employee of an agency, a Member of Congress, an officer or employee of Congress, or an employee of a Member of Congress in connection with the awarding of any Federal contract, the making of any Federal grant, the making of any Federal loan, the entering into of any cooperative agreement, and the extension, continuation, renewal, amendment, or modification of any Federal contract, grant, loan, or cooperative agreement.
2. If any funds other than Federal appropriated funds have been paid or will be paid to any person for influencing or attempting to influence an officer or employee of any agency, a Member of Congress, an officer or employee of Congress, or an employee of a Member of Congress in connection with this Federal contract, grant, loan, or cooperative agreement, the undersigned shall complete and submit Standard Form-LLL, “Disclosure Form to Report Lobbying,” in accordance with its instructions.
3. The undersigned shall require that the language of this certification be included in the award documents for all sub-awards at all tiers (including subcontracts, subgrants, and contracts under grants, loans, and cooperative agreements) and that all sub-recipients shall certify and disclose accordingly.

This certification is a material representation of fact upon which reliance was placed when this transaction was made or entered into. Submission of this certification is a prerequisite for making or entering into this transaction imposed by section 1352, title 31, U.S. Code. Any person who fails to file the required certification shall be subject to a civil penalty of not less than \$10,000 and not more than \$100,000 for each such failure.

A19 PROHIBITION OF SEGREGATED FACILITIES

(References: 2 CFR Part 200, Appendix II(C), 41 CFR Part 60-1)

PROHIBITION OF SEGREGATED FACILITIES

- a) The Contractor agrees that it does not and will not maintain or provide for its employees any segregated facilities at any of its establishments, and that it does not and will not permit its employees to perform their services at any location under its control where segregated facilities are maintained. The Contractor agrees that a breach of this clause is a violation of the Equal Employment Opportunity clause in this contract.
- b) "Segregated facilities," as used in this clause, means any waiting rooms, work areas, rest rooms and wash rooms, restaurants and other eating areas, time clocks, locker rooms and other storage or dressing areas, parking lots, drinking fountains, recreation or entertainment areas, transportation, and housing facilities provided for employees that are segregated by explicit directive or are in fact segregated on the basis of race, color, religion, sex, sexual orientation, gender identity, or national origin because of written or oral policies or employee custom. The term does not include separate or single-user rest rooms or necessary dressing or sleeping areas provided to assure privacy between the sexes.
- c) The Contractor shall include this clause in every subcontract and purchase order that is subject to the Equal Employment Opportunity clause of this contract.

A20 OCCUPATIONAL SAFETY AND HEALTH ACT OF 1970

(References: 29 CFR Part 1910)

All contracts and subcontracts that result from this solicitation incorporate by reference the requirements of 29 CFR Part 1910 with the same force and effect as if given in full text. The employer must provide a work environment that is free from recognized hazards that may cause death or serious physical harm to the employee. The employer retains full responsibility to monitor its compliance and their subcontractor's compliance with the applicable requirements of the Occupational Safety and Health Act of 1970 (29 CFR Part 1910). The employer must address any claims or disputes that pertain to a referenced requirement directly with the U.S. Department of Labor – Occupational Safety and Health Administration.

A21 PROCUREMENT OF RECOVERED MATERIALS

(References: 2 CFR § 200.323, 2 CFR Part 200, Appendix II(J), 40 CFR Part 247, 42 USC § 6901, et seq (Resource Conservation and Recovery Act (RCRA)))

PROCUREMENT OF RECOVERED MATERIALS

Contractor and subcontractor agree to comply with Section 6002 of the Solid Waste Disposal Act, as amended by the Resource Conservation and Recovery Act, and the regulatory provisions of 40 CFR Part 247. In the performance of this contract and to the extent practicable, the Contractor and subcontractors are to use products containing the highest percentage of recovered materials for items designated by the Environmental Protection Agency (EPA) under 40 CFR Part 247 whenever:

1. The contract requires procurement of \$10,000 or more of a designated item during the fiscal year;
or
2. The contractor has procured \$10,000 or more of a designated item using Federal funding during the previous fiscal year.

The list of EPA-designated items is available at www.epa.gov/smm/comprehensive-procurement-guidelines-construction-products.

Section 6002(c) establishes exceptions to the preference for recovery of EPA-designated products if the contractor can demonstrate the item is:

- a) Not reasonably available within a timeframe providing for compliance with the contract performance schedule;
- b) Fails to meet reasonable contract performance requirements; or
- c) Is only available at an unreasonable price.

A22 RIGHT TO INVENTIONS

(References: 2 CFR Part 200, Appendix II(F), 37 CFR Part 401)

RIGHTS TO INVENTIONS

Contracts or agreements that include the performance of experimental, developmental, or research work must provide for the rights of the Federal Government and the Owner in any resulting invention as established by 37 CFR part 401, Rights to Inventions Made by Non-profit Organizations and Small Business Firms under Government Grants, Contracts, and Cooperative Agreements. This contract incorporates by reference the patent and inventions rights as specified within 37 CFR § 401.14. Contractor must include this requirement in all sub-tier contracts involving experimental, developmental, or research work.

A23 SEISMIC SAFETY

(References: 49 CFR Part 41)

SEISMIC SAFETY

The Contractor agrees to ensure that all work performed under this contract, including work performed by subcontractors, conforms to a building code standard that provides a level of seismic safety substantially equivalent to standards established by the National Earthquake Hazards Reduction Program (NEHRP). Local building codes that model their code after the current version of the International Building Code (IBC) meet the NEHRP equivalency level for seismic safety.

A24 TAX DELINQUENCY AND FELONY CONVICTIONS

(References: Section 8113 of the Consolidated Appropriations Act, 2022 (Public Law 117-103) and similar provisions in subsequent appropriations acts.

DOT Order 4200.6 – Appropriations Act Requirements for Procurement and Non-Procurement Regarding Tax Delinquency and Felony Convictions)

CERTIFICATION OF OFFEROR/BIDDER REGARDING TAX DELINQUENCY AND FELONY CONVICTIONS

The applicant must complete the following two certification statements. The applicant must indicate its current status as it relates to tax delinquency and felony conviction by inserting a checkmark (☑) in the space following the applicable response. The applicant agrees that, if awarded a contract resulting from this solicitation, it will incorporate this provision for certification in all lower tier subcontracts.

Certifications

The applicant represents that it is (☐) is not (☐) a corporation that has any unpaid Federal tax liability that has been assessed, for which all judicial and administrative remedies have been exhausted or have lapsed, and that is not being paid in a timely manner pursuant to an agreement with the authority responsible for collecting the tax liability.

The applicant represents that it is (☐) is not (☐) a corporation that was convicted of a criminal violation under any Federal law within the preceding 24 months.

Note

If an applicant responds in the affirmative to either of the above representations, the applicant is ineligible to receive an award unless the Sponsor has received notification from the agency suspension and debarment official (SDO) that the SDO has considered suspension or debarment and determined that further action is not required to protect the Government's interests. The applicant therefore must provide information to the owner about its tax liability or conviction to the Owner, who will then notify the FAA Airports District Office, which will then notify the agency's SDO to facilitate completion of the required considerations before award decisions are made.

Term Definitions

Felony conviction: Felony conviction means a conviction within the preceding twenty four (24) months of a felony criminal violation under any Federal law and includes conviction of an offense defined in a section of the U.S. Code that specifically classifies the offense as a felony and conviction of an offense that is classified as a felony under 18 USC § 3559.

Tax Delinquency: A tax delinquency is any unpaid Federal tax liability that has been assessed, for which all judicial and administrative remedies have been exhausted, or have lapsed, and that is not being paid in a timely manner pursuant to an agreement with the authority responsible for collecting the tax liability.

A25 TERMINATION OF CONTRACT

(References: 2 CFR Part 200, Appendix II(B), FAA Advisory Circular 150/5370-10, Section 80-09)

TERMINATION FOR CONVENIENCE

The Owner may terminate this contract in whole or in part at any time by providing written notice to the Contractor. Such action may be without cause and without prejudice to any other right or remedy of Owner. Upon receipt of a written notice of termination, except as explicitly directed by the Owner, the Contractor shall immediately proceed with the following obligations regardless of any delay in determining or adjusting amounts due under this clause:

1. Contractor must immediately discontinue work as specified in the written notice.
2. Terminate all subcontracts to the extent they relate to the work terminated under the notice.
3. Discontinue orders for materials and services except as directed by the written notice.
4. Deliver to the Owner all fabricated and partially fabricated parts, completed and partially completed work, supplies, equipment and materials acquired prior to termination of the work, and as directed in the written notice.
5. Complete performance of the work not terminated by the notice.
6. Take action as directed by the Owner to protect and preserve property and work related to this contract that Owner will take possession.

Owner agrees to pay Contractor for:

1. Completed and acceptable work executed in accordance with the contract documents prior to the effective date of termination;
2. Documented expenses sustained prior to the effective date of termination in performing work and furnishing labor, materials, or equipment as required by the contract documents in connection with uncompleted work;
3. Reasonable and substantiated claims, costs, and damages incurred in settlement of terminated contracts with Subcontractors and Suppliers; and
4. Reasonable and substantiated expenses to the Contractor directly attributable to Owner's termination action.

Owner will not pay Contractor for loss of anticipated profits or revenue or other economic loss arising out of or resulting from the Owner's termination action.

The rights and remedies this clause provides are in addition to any other rights and remedies provided by law or under this contract.

TERMINATION FOR CAUSE

Section 80-09 of FAA Advisory Circular 150/5370-10 establishes standard language for conditions, rights, and remedies associated with Owner termination of this contract for cause due to default of the Contractor.

A26 TRADE RESTRICTION CERTIFICATION

(References: 49 USC § 50104, 49 CFR Part 30)

TRADE RESTRICTION CERTIFICATION

By submission of an offer, the Offeror certifies that with respect to this solicitation and any resultant contract, the Offeror –

1. is not owned or controlled by one or more citizens of a foreign country included in the list of countries that discriminate against U.S. firms as published by the Office of the United States Trade Representative (USTR);
2. has not knowingly entered into any contract or subcontract for this project with a person that is a citizen or national of a foreign country included on the list of countries that discriminate against U.S. firms as published by the USTR; and
3. has not entered into any subcontract for any product to be used on the Federal project that is produced in a foreign country included on the list of countries that discriminate against U.S. firms published by the USTR.

This certification concerns a matter within the jurisdiction of an agency of the United States of America and the making of a false, fictitious, or fraudulent certification may render the maker subject to prosecution under Title 18 USC § 1001.

The Offeror/Contractor must provide immediate written notice to the Owner if the Offeror/Contractor learns that its certification or that of a subcontractor was erroneous when submitted or has become erroneous by reason of changed circumstances. The Contractor must require subcontractors provide immediate written notice to the Contractor if at any time it learns that its certification was erroneous by reason of changed circumstances.

Unless the restrictions of this clause are waived by the Secretary of Transportation in accordance with 49 CFR § 30.17, no contract shall be awarded to an Offeror or subcontractor:

1. who is owned or controlled by one or more citizens or nationals of a foreign country included on the list of countries that discriminate against U.S. firms published by the USTR; or
2. whose subcontractors are owned or controlled by one or more citizens or nationals of a foreign country on such USTR list; or
3. who incorporates in the public works project any product of a foreign country on such USTR list.

Nothing contained in the foregoing shall be construed to require establishment of a system of records in order to render, in good faith, the certification required by this provision. The knowledge and information of a contractor is not required to exceed that which is normally possessed by a prudent person in the ordinary course of business dealings.

The Offeror agrees that, if awarded a contract resulting from this solicitation, it will incorporate this provision for certification without modification in all lower tier subcontracts. The Contractor may rely on the certification of a prospective subcontractor that it is not a firm from a foreign country included on the list of countries that discriminate against U.S. firms as published by USTR, unless the Offeror has knowledge that the certification is erroneous.

This certification is a material representation of fact upon which reliance was placed when making an award. If it is later determined that the Contractor or subcontractor knowingly rendered an erroneous certification, the Federal Aviation Administration (FAA) may direct through the Owner cancellation of the contract or subcontract for default at no cost to the Owner or the FAA.

A27 VETERAN'S PREFERENCE
(References: 49 USC § 47112(c))

VETERAN'S PREFERENCE

In the employment of labor (excluding executive, administrative, and supervisory positions), the Contractor and all sub-tier contractors must give preference to covered veterans as defined within Title 49 United States Code Section 47112. Covered veterans include Vietnam-era veterans, Persian Gulf veterans, Afghanistan-Iraq war veterans, disabled veterans, and small business concerns (as defined by 15 USC § 632) owned and controlled by disabled veterans. This preference only applies when there are covered veterans readily available and qualified to perform the work to which the employment relates.

A28 DOMESTIC PREFERENCES FOR PROCUREMENTS
(References: 2 CFR § 200.322, 2 CFR Part 200, Appendix II(L))

CERTIFICATION REGARDING DOMESTIC PREFERENCES FOR PROCUREMENTS

The Bidder or Offeror certifies by signing and submitting this bid or proposal that, to the greatest extent practicable, the Bidder or Offeror has provided a preference for the purchase, acquisition, or use of goods, products, or materials produced in the United States (including, but not limited to, iron, aluminum, steel, cement, and other manufactured products) in compliance with 2 CFR § 200.322.

WAGE RATES

"General Decision Number: IN20240004 01/05/2024

Modification Number Publication Date

0 01/05/2024

Superseded General Decision Number: IN20230004

ASBE0008-004 03/01/2023

State: Indiana

DEARBORN, FAYETTE, FRANKLIN, OHIO, RIPLEY SWITZERLAND AND UNION COUNTIES

Construction Type: Building

Counties: Brown, Clark, Dearborn, Decatur, Fayette, Floyd, Franklin, Harrison, Henry, Jennings, Ohio, Randolph, Ripley, Rush, Switzerland, Union and Wayne Counties in Indiana.

Rates Fringes

BUILDING CONSTRUCTION PROJECTS (does not include single family homes and apartments up to and including 4 stories)

Asbestos Workers/Insulator (Includes application of all insulating materials, protective coverings, coatings & finishings to all types of mechanical systems).....	\$ 33.08	20.69
HAZARDOUS MATERIAL HANDLER (Includes preparation, wettings, stripping, removal, scrapping, vacuuming, bagging & disposing of all insulation materials, whether they contain asbestos or not, from mechanical systems).....	\$ 25.00	13.70

Note: Contracts subject to the Davis-Bacon Act are generally required to pay at least the applicable minimum wage rate required under Executive Order 14026 or Executive Order 13658. Please note that these Executive Orders apply to covered contracts entered into by the federal government that are subject to the Davis-Bacon Act itself, but do not apply to contracts subject only to the Davis-Bacon Related Acts, including those set forth at 29 CFR 5.1(a)(1).

ASBE0018-001 06/01/2023

BROWN, DECATUR, HENRY AND RUSH COUNTIES

Rates Fringes

If the contract is entered into on or after January 30, 2022, or the contract is renewed or extended (e.g., an option is exercised) on or after January 30, 2022: the contractor must pay all covered workers at least \$17.20 per hour (or the applicable wage rate listed on this wage determination, if it is higher) for all hours spent performing on the contract in 2024.

ASBESTOS WORKER/HEAT & FROST INSULATOR (includes application of all insulating materials protective coverings, coatings and finishes to all types of mechanical systems).....	\$ 35.70	22.28
HAZARDOUS MATERIAL HANDLER (includes preparation, wettings, stripping, removal, scrapping, vacuuming, bagging & disposing of all insulation materials, whether they contain asbestos or not, from mechanical systems).....	\$ 23.00	14.40

If the contract was awarded on or between January 1, 2015 and January 29, 2022, and the contract is not renewed or extended on or after January 30, 2022: the contractor must pay all covered workers at least \$12.90 per hour (or the applicable wage rate listed on this wage determination, if it is higher) for all hours spent performing on that contract in 2024.

ASBE0051-005 03/01/2023

CLARK, FLOYD, HARRISON, and JENNINGS Counties

Rates Fringes

The applicable Executive Order minimum wage rate will be adjusted annually. If this contract is covered by one of the Executive Orders and a classification considered necessary for performance of work on the contract does not appear on this wage determination, the contractor must still submit a conformance request.

ASBESTOS WORKER/HEAT & FROST INSULATOR (Includes application of all insulating materials, protective coverings, coatings and finishings to all types of mechanical systems).....	\$ 28.96	18.78
HAZARDOUS MATERIAL HANDLER (includes preparation, wettings, stripping, removal,		

Additional information on contractor requirements and worker protections under the Executive Orders is available at <http://www.dol.gov/whd/govcontracts>.

scrapping, vaccuming, bagging
& disposing of all insulation
materials, whether they
contain asbestos or not, from
mechanical systems).....\$ 19.80 13.30

ASBE0079-002 07/01/2023

RANDOLPH AND WAYNE COUNTIES

Rates Fringes

ASBESTOS WORKER/HEAT & FROST
INSULATOR (Includes
application of all insulating
materials, protective
coverings, coatings &
finishings to all types of
mechanical systems).....\$ 33.04 16.14

HAZARDOUS MATERIAL HANDLER
(Includes preparation,
wetting, stripping, removal,
scrapping, vaccuming, bagging
& disposing of all insulation
materials, whether they
contain asbestos or not, from
mechanical systems)).....\$ 33.04 16.14

BOIL0105-002 01/01/2012

DEARBORN and SWITZERLAND COUNTIES

Rates Fringes

BOILERMAKER.....\$ 32.99 23.72

BOIL0374-001 01/01/2023

REMAINING COUNTIES

Rates Fringes

BOILERMAKER.....\$ 41.06 34.07

BRIN0004-019 06/01/2023

LOUISVILLE

CLARK, FLOYD AND HARRISON COUNTIES

Rates Fringes

BRICKLAYER.....\$ 32.28 15.99

Marble, Tile Layer & Terrazzo
Worker.....\$ 26.28 7.72

TILE FINISHER.....\$ 18.58 6.69

BRIN0004-022 06/01/2023

BROWN, DEARBORN, DECATUR, JENNINGS, OHIO, RIPLEY and SWITZERLAND
COUNTIES

Rates Fringes

Bricklayer, Stonemason.....\$ 33.29 17.44
TERRAZZO FINISHER.....\$ 23.38 13.15
TERRAZZO WORKER/SETTER.....\$ 36.38 17.24
Tile & Marble Finisher.....\$ 24.33 13.16
Tile & Marble Setter; Mosaic
Worker.....\$ 35.63 17.23

BRIN0019-002 06/01/2023

MUNCIE

FAYETTE, FRANKLIN, HENRY, RANDOLPH, RUSH, UNION and WAYNE
COUNTIES

Rates Fringes

Bricklayer, Stonemason,
Pointer, Caulker & Cleaner.....\$ 33.83 20.14
TERRAZZO FINISHER.....\$ 23.38 13.15
TERRAZZO WORKER/SETTER.....\$ 36.38 17.24
Tile & Marble Finisher.....\$ 23.38 13.15
Tile & Marble Setter; Mosaic
Worker.....\$ 35.63 17.23

CARP0002-021 04/01/2023

DEARBORN, JENNINGS, OHIO, RIPLEY AND SWITZERLAND COUNTIES

Rates Fringes

CARPENTER

Carpenter.....\$ 29.23 23.70
Piledriver.....\$ 28.06 21.77

CARP0104-001 10/01/2023

FAYETTE, HENRY, RANDOLPH, UNION AND WAYNE COUNTIES

Rates Fringes

Carpenters:

Carpenters, Drywall
Installers, Piledrivers....\$ 33.81 23.39
Millwright.....\$ 35.00 25.00
Soft Floor Layers.....\$ 33.47 20.07

CARP0175-002 04/01/2023

CLARKE, FLOYD AND HARRISON COUNTIES

Rates Fringes

CARPENTER

Carpenter.....\$ 28.18 24.19
Piledriver.....\$ 27.01 22.94

CARP0999-009 06/01/2023

CLARK, FLOYD, AND HARRISON COUNTIES

Rates Fringes

MILLWRIGHT.....\$ 32.28 27.11

CARP1080-003 06/01/2023

DEARBORN, JENNINGS, OHIO, RIPLEY AND SWITZERLAND COUNTIES

	Rates	Fringes
MILLWRIGHT.....	\$ 35.00	24.87

CARP1775-001 10/01/2023

BROWN, DECATUR, FRANKLIN AND RUSH COUNTIES

	Rates	Fringes
Carpenters:		
Carpenters, Drywall		
Installers, Piledrivers.....	\$ 33.07	20.07
Millwright.....	\$ 35.00	25.00
Soft Floor Layers.....	\$ 33.47	20.07

ELEC0071-006 01/02/2019

DEARBORN, OHIO, and SWITZERLAND COUNTIES

	Rates	Fringes
Line Construction:		
Equipment Operator.....	\$ 33.62	13.46
Groundman.....	\$ 24.17	11.38
Lineman & Cable Splicers....	\$ 38.27	14.48

ELEC0212-009 06/07/2023

DEARBORN, OHIO, and SWITZERLAND COUNTIES

	Rates	Fringes
ELECTRICIAN.....	\$ 34.41	21.55

ELEC0369-009 05/31/2021

CLARK, FLOYD, and HARRISON COUNTIES

	Rates	Fringes
ELECTRICIAN.....	\$ 33.85	18.72
Line Construction:		
Groundman.....	\$ 13.83 **	6.35
Lineman; Equipment Operator.	\$ 22.25	6.35

ELEC0481-002 05/31/2023

DECATUR, JENNINGS, RIPLEY AND RUSH COUNTIES

	Rates	Fringes
ELECTRICIAN.....	\$ 40.20	26.31

ELEC0725-001 10/01/2022

BROWN COUNTY

	Rates	Fringes
--	-------	---------

ELECTRICIAN.....	\$ 40.00	21.96
------------------	----------	-------

ELEC0725-008 06/01/2022

BROWN COUNTY

	Rates	Fringes
--	-------	---------

Communication Technician.....	\$ 30.00	18.07
-------------------------------	----------	-------

Includes the installation, operation, inspection, maintenance, repair and service of radio, television, recording, voice sound and vision production and reproduction apparatus, equipment and appliances used for domestic, commercial, education, entertainment and private telephone systems.

ELEC0855-001 06/01/2023

FAYETTE, FRANKLIN, HENRY, RANDOLPH, UNION AND WAYNE COUNTIES

	Rates	Fringes
--	-------	---------

ELECTRICIAN.....	\$ 35.30	20.25
------------------	----------	-------

ELEV0011-003 01/01/2023

DEARBORN, OHIO and SWITZERLAND COUNTIES

	Rates	Fringes
--	-------	---------

ELEVATOR MECHANIC.....	\$ 52.72	37.335+a+b
------------------------	----------	------------

PAID HOLIDAYS:

a. New Year's Day, Memorial Day, Independence Day, Labor Day, Vetern's Day, Thanksgiving Day, the Friday after Thanksgiving, and Christmas Day.

b. Employer contributes 8% of regular hourly rate to vacation pay credit for employee who has worked in business more than 5 years; 6% for less than 5 years' service.

ELEV0020-002 01/01/2023

CLARK, FLOYD and HARRISON COUNTIES

	Rates	Fringes
--	-------	---------

ELEVATOR MECHANIC.....	\$ 51.94	37.335
------------------------	----------	--------

PAID HOLIDAYS:

a. New Year's Day, Memorial Day, Independence Day, Labor Day, Vetern's Day, Thanksgiving Day, the Friday after Thanksgiving, and Christmas Day.

b. Employer contributes 8% of regular hourly rate to vacation pay credit for employee who has worked in business more than 5 years; 6% for less than 5 years' service.

ELEV0034-003 01/01/2023

BROWN, DECATUR, FAYETTE, FRANKLIN, HENRY, JENNINGS, RANDOLPH, RIPLEY, RUSH, UNION and WAYNE COUNTIES

	Rates	Fringes
ELEVATOR MECHANIC.....	\$ 55.30	37.335+a+b

a) PAID HOLIDAYS: New Year's Day, Memorial Day, Independence Day, Labor Day, Vetern's Day, Thanksgiving Day, the Friday after Thanksgiving, and Christmas Day.

b) Employer contributes 8% of regular hourly rate to vacation pay credit for employee with more than 5 years of service; 6% for less than 5 years' service.

ENGI0103-006 04/01/2021

FAYETTE, HENRY, RANDOLPH, RUSH, UNION, and WAYNE COUNTIES

	Rates	Fringes
Power equipment operators:		
GROUP 1.....	\$ 37.08	19.96
GROUP 2.....	\$ 36.13	19.96
GROUP 3.....	\$ 32.08	19.96
GROUP 4.....	\$ 28.30	19.96

POWER EQUIPMENT OPERATORS

GROUP 1: Air Compressor (pressurizing Shafts, tunnels & drivers) Air Tugger; Auto Patrol; Back Filler; Back Hoe; Boom Cat; Boring Machine; Bull Dozer; Caisson Drilling Machine; Cherry Picker; Compactor (with dozer blade); Concrete Mixer (dual drum); Concrete plant; Concrete Pump; Crane with all attachments; Crane- Electric overhead; Derrick; Ditching Machine (18' and over); Dredge; Elevators (when hoisting material or tools); Fork Lift (machinery); Formless Paver; Generator (power for welders of compressor); Gradall; Helicopter; Helicopter Winch Operator; High Lift-Front End Loader; Hoist-Material and/or Personnel over 3 Floors; Locomotive; Mechanic on job site; Mucking Machine; Panel Board Concrete Plant; Pile Driver; Push Cat; Scoop & Tractor; Scraper-Rubber Tired; Spreader-Tractor Mounted; Straddle Carrier- Ross Type; Sub Base Finish Machine (C.M.I. or smiliar); Tower Crane; Tractor with Backhoe (over 1/2 yard); Welder (craft)

GROUP 2: A Frame Truck; Batchter Plant (automatic dry batch); Bending Machine-Power Driven; Bituminous Mixer; Bituminous Paver; Bituminous Plant Engineer; Boatman; Bull Float; Compactor or Tamper-Self Propelled; Concrete Mixer (21 cu. ft. or over); Concrete Spreader-Power Driven; Dinkey Engine; Ditching Machine; Ditching Machine (less than 18"); Drilling Machine; Finish Machine & Bull Float; Finishing Machine; Fireman-Pile Driving and Boilers; Fork Lift-Masonry & Material; Gunite Machine; Head Greaser; Hoist-Material and/or personnel 3 floors and under; Mechanic in shop; Mesh Depresser-Mesh Placer; P.C.C. Concrete Belt Placer; Ruller-Asphalt, stone & sub base; Sheepsfoot Roller- Self Propelled; Shop Mule; Spreader or

Base Paver-Self Propelled; Sub Grader; Throttle valve with air compressor or boiler; Tractor with Backhoe (1/2 yard & under); Tractor-high lift-farm type; Tractor-Industrial Type; Tractor with Winch; Well Points; Winch Trick

GROUP 3: Air Compressor (210 cu. ft. & over); bituminous Distributor; Chair Cart; Concrete Curing Machine; Concrete Saw; Dope Pot Power Agitated; Flex Plane; Form Grader; Hydrohammer; Jacks-Hydraulic-Power Driven; Minor Equipment opr. 3,4, or 5; Paving Joint Machine; Post Hole Digger; Roller-Earth; Throttle Valve; Track Jack-Power Driven; Tractor-Farm Type; Truck Crane Driver

GROUP 4: Air Compressor (less than 210 cu. ft.); Concrete Mixer (under 21cu. ft.); Conveyor; Generator; Mechanical Heater; Oiler; Operator-2 pieces of miner equipment; Power Broom; Pump; Welding Machine

ENGI0181-012 04/01/2023

BROWN, CLARK, DEARBORN, DECATUR, FLOYD, FRANKLIN, HARRISON, JENNINGS, OHIO, RIPLEY, and SWITZERLAND COUNTIES

	Rates	Fringes
Power equipment operators:		
GROUP A.....	\$ 38.53	19.22
GROUP B.....	\$ 30.40	19.22

POWER EQUIPMENT OPERATOR CLASSIFICATIONS

GROUP A: A-Frame Winch Truck, Articulating dump, autograde (CMI), auto patrol, ballast regulator (RR), batcher plant (electrical control concrete), bending machine (pipe), bituminous plant (engineer), bituminous plant, bituminous mixer travel plant, bituminous paver, bituminous roller, boring machine, buck hoist, bull dozer, cable way, Chicago boom, chimney hoist, clamshell concrete mixer (21 cu. ft. or over), concrete paver, concrete pump (crete), construction elevator (Allmac or similar) crane, craneman, crawler backhoe, crawler high-lift, crusher plant, derrick, derrick boat, dinkey, directional/boring machine, dope pots (pipeline), double drum tugger (electric or air), dragline, dredge operator, dredge engineer, drill operator, elevating grader, extendable boom forklift, formless paver, gantry creane, gator (or similar type tiller), gradeall, grader, grademan, greaser (on grease facility servicing heavy equipment), G.P.S System (on equipment within the classifications), grout pump, head greaser, helicopter crew, Hetherington paver, hoist (motroized, gas or disel), hydraulic crane, hydro blaster, Industrial type forklift (over 9,000 lbs), laser concrete screed, laser or remote controlled equipment (within the classifications), locomotive crane, locomotive, mechanic, mobile mixer, motor crane, mucking machine, multiple tamping machine (RR) overhead crane, pile driver, pulls push dozer, push boats, roller (sheep foot), rough terrain crane, R.T. backhoe, R.T. endloader, Ross carrier, scoop, shovel, side boom, skidsteer loader (bobcat or similar type), swing crane, tail boom, tar machine (pipeline), tower crane, trench machine, welder (heavy duty), truck mounted concrete pump, truck-mounted drill, vacuum truck, well point, whirleys.

FRANKLIN (S. 3/4), OHIO, RIPLEY (REM. OF COUNTY), SWITZERLAND (REM. OF COUNTY) and JENNINGS (NE TIP) COUNTIES

GROUP B: Air Compressor (1 or more, 600 cfm and over) air compressor with throttle valve, bituminous distributor, brakeman, bullfloat, cement gun, concrete mixer, concrete mixer, concrete saw, concrete spreader or puddlers, conveyor, deck hand oiler, deck engine, drill helper, earth roller, electric vibrator compactor (earth or rock), elevator (in-plant, automatic), finishing machine, fireman, form grader, generator, guard-rail driver, heater, oiler, Industrial type forklift (9,000 lbs and under), material pump, motor boats, paving joint machine, post hole digger, power broom, power traffic signals, rock roller, rocker spreader, Roller (earth or rock), spike machine (RR), steam jenny, sub grader, tamping machine, truck crane oiler, truck mounted drill oiler, Tugger (one-drum, air or electric) vibrator, vibro-piling hammer-hydraulic hammer or auger, water pump, widener (apsco or similar type) welding machine, JLG lifts and scissor lifts or similar machine.

	Rates	Fringes
IRONWORKER, REINFORCING.....	\$ 31.79	24.62

IRON0147-003 06/01/2023

RANDOLPH COUNTY

	Rates	Fringes
IRONWORKER.....	\$ 33.00	25.59

IRON0290-003 06/01/2023

FAYETTE (REMAINDER OF COUNTY), RANDOLPH (S. PART OF COUNTY EXCLUDING WINCHESTER BUT INCLUDING UNION CITY) UNION AND WAYNE COUNTIES

IRON0022-002 06/01/2023

BROWN, DECATUR (W 3/4), FAYETTE (W 1/2), FRANKLIN (NW TIP), HENRY, JENNINGS (NW TIP), RANDOLPH (SW TIP), AND RUSH COUNTIES:

	Rates	Fringes
IRONWORKER.....	\$ 35.45	25.39

The following holidays shall be observed: New Year's Day, Memorial Day, Independence Day, Labor Day, Thanksgiving Day and the day after Thanksgiving and Christmas Day. Any holiday which occurs on a Sunday shall be observed the following Monday, unless the legal observance of these holidays is changed by law.

IRON0044-007 06/01/2023

DEARBORN, DECATUR (REMAINDER OF COUNTY), FAYETTE (SE CORNER), FRANKLIN (S. 3/4), OHIO, RIPLEY (REM. OF COUNTY), SWITZERLAND (REM. OF COUNTY), & JENNINGS (NE TIP) COUNTIES:

	Rates	Fringes
IRONWORKER		
Fence Erectors.....	\$ 30.75	22.30
Structural & Ornamental.....	\$ 32.37	22.30

IRON0070-007 06/01/2023

CLARK, FLOYD, HARRISON, JENNINGS (S 2/3), SWITZERLAND (SW TIP), AND RIPLEY (SW TIP) COUNTIES

	Rates	Fringes
IRONWORKER.....	\$ 32.59	24.62

IRON0070-019 06/01/2022

DEARBORN, DECATUR (REM. OF COUNTY), FAYETTE (SE CORNER),

	Rates	Fringes
IRONWORKER.....	\$ 32.69	24.50

LABO0741-002 06/01/2023

BROWN, DEARBORN, DECATUR, FRANKLIN, JENNINGS, OHIO, and RIPLEY COUNTIES

	Rates	Fringes
Laborers:		
GROUP 1.....	\$ 25.98	17.50
GROUP 2.....	\$ 26.73	17.50
GROUP 3.....	\$ 27.48	17.50

LABORERS CLASSIFICATIONS

GROUP 1: Building and Construction Laborers; Scaffold Builders (other than for masons or plasterers); Railroad Workers; Masonry Wall Washers (interior & exterior); Portable Water Pumps with Discharge up to 3 Inches; Handling of Creosote Lumber or Like Treated Material (excluding railroad material); Asphalt Rakers and Lutemen; Earth Compactors; Jackmen and Sheetmen working ditches deeper than six (6) feet in depth; Laborers in Ditches six (6) feet in depth or deeper; Assembly of Unicrete Pump; Tile Layers (sewer or field) and Sewer Pipe Layers (metallic or non-metallic); Motor driven wheelbarrows and concrete buggies; Hyster Operators; Pump Crete Assemblers; Core Drill Operators; Cement, Lime or Silica Clay Handler (bulk or bag); Handling of toxic material damaging to clothing; Pneumatic Spikers; Deck Engine and Winch Operators; Water main and cable ducking (metallic and non-metallic); Screed Man or Screw Operator on Asphalt Paver; Chain Saw and Demolition Saw Operators; Concrete Saw; Concrete Conveyor Assemblers; Applying of Curing Compound; Sinking of Wellpoints; Dewatering Header Systems.

GROUP 2: Plaster Tenders; Mortar Mixers; Welders (acetylene

or electric); Cutting Torch or Burner; Cement Nozzle Laborers; Cement Gun Operators; Scaffold Builders for Plasterers; Scaffold Builders for Masons; Water Blast Machine Operators; Air Tool Operators and all Pneumatic Tool Operators; Air and Electric Vibrators and Chipping Hammer Operators; Asbestos Removal; Hazardous Waste Removal; All Boiler Setters Laborers, including Expeditors, Bottom Men and Bell Men.

GROUP 3: Dynamite Men, Mason Tenders, Drillers-air track or wagon drilling for explosives.

LABO0795-001 06/01/2023

CLARK, FLOYD, HARRISON, and SWITZERLAND COUNTIES

Rates Fringes

Laborers:

GROUP 1.....	\$ 23.35	17.85
GROUP 2.....	\$ 24.10	17.85
GROUP 3.....	\$ 24.85	17.85

LABORER CLASSIFICATIONS:

GROUP 1: Building and Construction Laborers, Scaffold Builders (other than for Masons or Plasterers), Mechanic Tenders, Rodmen & Chainmen, Signalmen & Flagmen, Window Washers & Cleaners, Waterboys & Toolhousemen, Railroad Workers, Masonry Wall Washers (interior & Exterior), All Portable Water Pumps with Discharge up to three (3) inches, Waterproofing, Handling of creosote lumber or like treated Material (excluding Railroad Material), Asphalt Rakers & Luteman, Kettlemen, Air Tool Operators and all Pneumatic Tool Operators, Air and Electric Vibrators and Chipping Hammer Operators, Earth Compactors, Jackman & Sheetmen working Ditches Deeper Than Six (6) feet in depth, Laborers working Ditches Six (6) feet in Depth or Deeper, Assembly of Unicrete Pump, Tile Layers (sewer or field) & Sewer Pipe Layers (metallic or non-metallic), Motor Driven Wheelbarrows and Concrete Buggies Hyster Operators, Pump Crete Assemblers, Core Drill Operators, Cement, Lime or Silica Clay Handers (bulk or bag), Handling of Toxic Materials Damaging to Clothing, Pneumatic Spikers, Deck Engine & Winch Operators, Water Main & Cable Ducking (Metallic and Non-Metallic), Screed Man or Screw Operator on Asphalt Paver, Chain Saw and Demolition Saw Operators, Concrete Conveyor Assemblers, Asbestos Removal, Hazardous Waste Removal.

GROUP 2: Plaster Tenders, Mortar Mixers, Welders (Acetylene or Electric), Cutting Torch or Burner, Cement Nozzle Laborers, Cement Gun Operators, Scaffold Builders when Working for Plasterers, Scaffold Builders When Working for Masons Water Blast Machine Operators.

GROUP 3: Dynamite Men, Mason Tenders, Drillers-Air Track or Wagon Drilling for Explosives.

LABO1112-002 06/01/2023

RANDOLPH COUNTY

Rates Fringes

Laborers:

GROUP 1.....	\$ 25.66	17.50
GROUP 2.....	\$ 26.41	17.50
GROUP 3.....	\$ 27.16	17.50

LABORER CLASSIFICATIONS

GROUP 1: Building and construction laborers; scaffold builders (other than for masons of plasterers); mechanic tenders; window washers and cleaners; railroad workers; masonry wall washers; portable water pumps with discharge up to 3 inches; signal & flag person

GROUP 2: Waterproofing; hauling of creosote lumber or like treated material (excluding railroad material); asphalt rakers and lutemen; kettlemen; air tool operator; pneumatic tool operator; air & electric vibrators and chipping hammer operator; earth compactors; jackman & sheetmen in ditches more than 6 feet deep; laborers in ditches 6' deep or deeper; assembly of unicrete pump; tile layers (sewer or field); sewer pipe layers; motor-driven wheelbarrows and concrete buggies; hyster operator; pumpcrete assemblers; core drill operator; cement, lime or silica clay handlers; handling of toxic materials damaging to clothing; pneumatic spikers; deck engine & winch operator; water main & cable ducking; screed man or screw operator on asphalt paver; chain saw & demolition saw operator; concrete conveyor assembler; asbestos removal; hazardous waste removal

GROUP 3: Plaster tenders; mortar mixers; welders (acetylene or electric); cutting torch or burner; cement nozzle laborers; cement gun operators; scaffold builders for plasterers; scaffold builders; water blast machine operator

LABO1112-004 06/01/2023

FAYETTE, HENRY, RUSH, WAYNE, and UNION COUNTIES

Rates Fringes

Laborers:

GROUP 1.....	\$ 25.66	16.00
GROUP 2.....	\$ 26.41	16.00
GROUP 3.....	\$ 27.16	16.00

LABORER CLASSIFICATIONS

GROUP 1: Building and Construction Laborers; Scaffold Builders (other than for Masons or Plasterers); Mechanic Tenders; Civil Engineer Tenders and Surveyor tenders; Rodmen & Chainmen; Signalmen & Flagmen; Window Washers & Cleaners; Waterboys & Toolhousemen; Railroad Workers; Masonry Wall Washers (interior & exterior); Cement Finisher Helpers; All Portable Water Pumps with discharge up to three (3) inches, Waterproofing; Handling of Creosote Lumber or like treated material (excluding railroad material); Asphalt Rakers & Lutemen; Kettlemen; Air Tool Operators and all pneumatic tool operators, air and electric vibrators and chipping hammer operators); Earth Compactors; Jackmen & Sheetmen working

ditches deeper than six (6) feet in depth; Laborers working ditches six (6) feet in depth or deeper; Assembly of Unicrete Pump; Tile Layers (sewer or field) & sewer pipe layers (metallic or non-metallic); Motor driven wheelbarrows and concrete buggies; Hyster Operators; Pump Crete Assemblers; Core Drill Operators; Cement, Lime or Silica Clay Handlers (bulk or bag); Handling of Toxic Materials Damaging to Clothing; Pneumatic Spikers; Deck Engine & Winch Operators; Water Main & Cable Ducking (metallic and non-metallic); Screed man or screw operator on asphalt paver; Chain saw and demolition saw operators; Concrete conveyor assemblers; Asbestos removal; Hazardous waste removal.

GROUP 2: Plaster tenders; Mortar mixers; Welders (acetylene or electric); Cutting torch or burner; Cement nozzle laborers; Cement gun operators; Scaffold builders when working for plasterers; Scaffold builders when working for masons; Water blast machine operators.

GROUP 3: Dynamite men; Mason Tenders; Drillers-air track or wagon drilling for explosives.

PAIN0012-006 05/01/2023

COMMERCIAL AND INDUSTRIAL

DEARBORN, OHIO, RIPLEY AND SWITZERLAND COUNTIES:

Rates Fringes

PAINTER

Bridges, Lead Abatement.....	\$ 26.30	11.35
Brush & Roller,		
Paperhanger, Drywall Taping.	\$ 29.57	12.42
Sandblasting, Waterblasting.	\$ 30.93	13.21
Spray.....	\$ 28.57	13.21

PAIN0047-001 06/01/2023

BROWN, DECATUR AND JENNINGS COUNTIES

Rates Fringes

PAINTER

Brush, Roller.....	\$ 29.52	15.89
Spray and Sand-Blasting.....	\$ 30.52	15.89

PAIN0118-007 06/01/2023

CLARK, FLOYD AND HARRISON COUNTIES

Rates Fringes

PAINTER

Brush, Roller,		
Paperhanger, Spray,		
Sandblast & Waterblast.....	\$ 21.91	15.05

PAIN0387-004 11/01/2023

DEARBORN, FRANKLIN, OHIO, RIPLEY, and SWITZERLAND COUNTIES

Rates Fringes

GLAZIER.....\$ 31.95 17.75

PAIN0669-002 05/01/2023

FAYETTE, FRANKLIN, HENRY, RANDOLPH, RUSH, UNION AND WAYNE

Rates Fringes

Painters:

Brush; Roller;		
Paperhanging; Drywall		
Finishers.....	\$ 23.70	15.79
Spray/Waterblasting;		
Sandblasting.....	\$ 23.70	15.79

PAIN1165-008 07/01/2023

CLARK, FLOYD, HARRISON COUNTIES

Rates Fringes

GLAZIER.....\$ 30.87 18.83

PAIN1165-015 01/01/2023

BROWN, DECATUR, FAYETTE, HENRY, JENNINGS, RANDOLPH, RUSH, UNION, and WAYNE COUNTIES

Rates Fringes

GLAZIER.....\$ 31.92 19.43

PLAS0132-007 06/22/2018

DEARBORN, FRANKLIN (Southern half, south of a line running East and West established South of Brookville), OHIO, RIPLEY and SWITZERLAND COUNTIES

Rates Fringes

PLASTERER.....\$ 24.25 14.65

PLAS0692-003 06/01/2023

AREA #46

BROWN and CLARK COUNTIES

Rates Fringes

PLASTERER.....\$ 29.89 16.63

PLAS0692-011 06/01/2023

AREA #83

DECATUR, FAYETTE, FRANKLIN, HENRY, RANDOLPH, RUSH, UNION and WAYNE COUNTIES

	Rates	Fringes
CEMENT MASON/CONCRETE FINISHER...	\$ 29.25	19.34
PLASTERER.....	\$ 28.14	15.90

PLAS0692-027 04/01/2023		
AREA #566		
CRAWFORD, DAVIESS, DUBOIS, GIBSON, HARRISON, KNOX, MARTIN, PERRY, PIKE, POSEY, SPENCER, VANDERBURGH and WARRICK COUNTIES		

	Rates	Fringes
CEMENT MASON/CONCRETE FINISHER...	\$ 29.00	19.71

PLAS0692-033 05/01/2023		
BROWN, CLARKE, DEARBORN, FLOYD, FRANKLIN (SOUTHERN 1/2), JENNINGS, OHIO, RIPLEY AND SWITZERLAND COUNTIES		

	Rates	Fringes
CEMENT MASON/CONCRETE FINISHER AREA #821.....	\$ 28.12	16.90

PLUM0136-002 04/01/2023		

REMAINING COUNTIES

	Rates	Fringes
Plumbers and Pipefitters.....	\$ 40.82	20.92

PLUM0392-006 06/01/2023		

DEARBORN, OHIO, RIPLEY, AND SWITZERLAND COUNTIES

	Rates	Fringes
Plumbers and Pipefitters.....	\$ 38.62	28.39

PLUM0440-004 06/01/2018		

FAYETTE, FRANKLIN, HENRY, RANDOLPH, RUSH, UNION and WAYNE COUNTIES

	Rates	Fringes
Plumber and Steamfitter.....	\$ 37.67	16.79

PLUM0502-001 08/01/2016		

CLARK, FLOYD AND HARRISON COUNTIES

	Rates	Fringes
PLUMBER/PIPEFITTER.....	\$ 32.00	20.13

ROOF0042-005 08/01/2023		

DEARBORN, OHIO and RIPLEY COUNTIES

	Rates	Fringes
Roofers:		
Roofer.....	\$ 32.00	19.69

ROOF0075-001 05/01/2023		

FAYETTE, RANDOLPH, UNION, and WAYNE Counties

	Rates	Fringes
ROOFER		
Composition.....	\$ 25.63	20.81
Slate & Tile.....	\$ 27.25	20.81

ROOF0119-005 09/01/2023		

	Rates	Fringes
ROOFER.....	\$ 30.00	12.84

ROOF0147-003 04/01/2018		

CLARK, FLOYD, HARRISON and SWITZWELAND COUNTIES

	Rates	Fringes
ROOFER.....	\$ 24.43	10.20

SHEE0020-012 07/01/2023		

BROWN, DECATUR, FAYETTE, FRANKLIN, HENRY, JENNINGS, RIPLEY, RUSH AND UNION

	Rates	Fringes
Sheet metal worker.....	\$ 40.91	25.22

SHEE0024-006 06/01/2023		

RANDOLPH and WAYNE COUNTIES

	Rates	Fringes
Sheet metal worker.....	\$ 31.23	25.79

SHEE0024-012 06/01/2023		

DEARBORN AND OHIO COUNTIES

	Rates	Fringes
Sheet metal worker.....	\$ 34.32	22.82

SHEE0110-007 12/01/2013		

CLARK, FLOYD, HARRISON and SWITZERLAND COUNTIES

	Rates	Fringes
Sheet Metal Worker.....	\$ 28.66	18.03

TEAM0135-002 04/01/2021

BROWN, CLARK, DEARBORN, DECATUR, FAYETTE, FLOYD, FRANKLIN,
HENRY, JENNINGS, OHIO, RANDOLPH, RIPLEY, RUSH, SWITZERLAND,
UNION, AND WAYNE COUNTIES

	Rates	Fringes
Truck drivers:		
GROUP 1.....	\$ 30.40	.37+A
GROUP 2.....	\$ 30.90	.37+A
GROUP 3.....	\$ 31.10	.37+A
GROUP 4.....	\$ 31.25	.37+A
GROUP 5.....	\$ 31.75	.37+A

A: \$36.40 PER DAY & 450.00 PER WEEK.

TRUCK DRIVER CLASSIFICATIONS

GROUP 1: Single Axle Trucks seven(7) cu.yds. or less than ten and one-half (10 1/2) tons, dumpsters, scoop-mobiles five (5) cu. yds. and under or less than seven and one-half (7 1/2) tons, mixer trucks three (3) cu.yds. and under, air compressors and welding machines, including those pulled by separate units, batch trucks - wet or dry - 2'''34-E batches or less, truck driver helpers, warehousemen, mechanic's helpers, greasers and tiremen, all pick-up trucks and other vehicles. Drivers on dumpsters or similar dumpsters, mounted on a four (4) wheel truck rate two (2) cu.yds. or less and small pallet type fork-lift operator and drivers on pallet jacks or similar type equipment.

GROUP 2: Drivers on tandem axle eighteen (18) cu.yds. or twenty-four (24) tons gross, six (6) wheel trucks, Koehring or similar dumpsters, tract trucks, Euclids, hug bottom dumps, tournapulls, tournatrailers, tournarockers, or similar equipment when used for transportation purposes under nine (9) cu.yds. or less than thirteen and one-half (13 1/2) tons, tandems and semi-trailer service trucks, mixer trucks over three (3) cu.yds. and including six and one-half (6 1/2) cu.yds., fork lift, four (4) wheel A frame trucks when used for transportation purposes, four (4) wheel winch trucks, pavement breakers, batch trucks-wet or dry-over 2 up to and including 4-'''34-E''' batches, two (2) men oil distributors, fork-lift under four (4) ton and vacuum trucks.

GROUP 3: Koehring or similar dumpsters, tract trucks, sem-trailer water trucks, Euclids, hug bottom dumps, tournapulls, tournatrailers, tournarockers, tractor trailers, tandems Q frame winch trucks, hydrolift trucks or similar equipment when used for transportation purposes, mixer trucks over six and one-half (6 1/2) cu.yds. batch trucks wet or dry over 4-'''34-E'''batches single axle low boy trailers, and contractor's mechanics when working on equipment operated by employees within the bargaining unit; six (6) wheel pole trailers and one (1) man oil distributors, fork-lift over four (4) ton and mobile mixers

GROUP 4: Drivers on heavy equipment over sixteen (16) cu.yds. or twenty-four ton, such as Koehring or similar dumpsters, tract trucks, Euclids, hug bottom dumps,

trounapulls, trounarockers or similar equipment when used for transportation purposes, pole trailers over six (6) wheels, water pulls, low-boy trailers tandem axles, quad axle or more no-weight limitation, diesel and /or heavy equipment mechanics when working on equipment operated by employees within the bargaining unit.

GROUP 5: Mechanic, with his own tools.

TEAM0215-006 04/01/2023

HARRISON COUNTY

	Rates	Fringes
Truck drivers:		
GROUP 1.....	\$ 25.08	20.95
GROUP 2.....	\$ 25.54	20.95
GROUP 3.....	\$ 25.76	20.95

GROUP 1 Pickup Trucks, Winch Trucks, Warehouseman, Mechanic, Street Sweepers, Single axle Trucks

GROUP 2 Tandem Trucks or Dump Trucks; Farm Tractor-Pulling Trailer; Bituminous Distributors, Pavement Breakers

GROUP 3 Mixer Trucks, all types; Lowboys, all types; Semi-trucks, all types; All Tri-axle Dump Trucks; Articulated End Dumps; End Dumps; Heavy Equipment Type Water Wagons; Hazardous Waste Warehouseman; Hazardous Waste Driver; and Drivers on equipment when not self-loaded or pusher loaded, such as Koehring or similar dumpsters, track trucks, Euclid bottom dump and hug bottom dump, Tournatrailers, Tournarockers or similar equipment

WELDERS - Receive rate prescribed for craft performing operation to which welding is incidental.

=====
=

** Workers in this classification may be entitled to a higher minimum wage under Executive Order 14026 (\$17.20) or 13658 (\$12.90). Please see the Note at the top of the wage determination for more information. Please also note that the minimum wage requirements of Executive Order 14026 are not currently being enforced as to any contract or subcontract to which the states of Texas, Louisiana, or Mississippi, including their agencies, are a party.

Note: Executive Order (EO) 13706, Establishing Paid Sick Leave for Federal Contractors applies to all contracts subject to the Davis-Bacon Act for which the contract is awarded (and any solicitation was issued) on or after January 1, 2017. If this contract is covered by the EO, the contractor must provide employees with 1 hour of paid sick leave for every 30 hours they work, up to 56 hours of paid sick leave each year. Employees must be permitted to use paid sick leave for their own illness, injury or other health-related needs, including preventive care; to assist a family member (or person who is like family to the employee) who is ill, injured, or has other

health-related needs, including preventive care; or for reasons resulting from, or to assist a family member (or person who is like family to the employee) who is a victim of, domestic violence, sexual assault, or stalking. Additional information on contractor requirements and worker protections under the EO is available at <https://www.dol.gov/agencies/whd/government-contracts>.

Unlisted classifications needed for work not included within the scope of the classifications listed may be added after award only as provided in the labor standards contract clauses (29CFR 5.5 (a) (1) (iii)).

The body of each wage determination lists the classification and wage rates that have been found to be prevailing for the cited type(s) of construction in the area covered by the wage determination. The classifications are listed in alphabetical order of ""identifiers"" that indicate whether the particular rate is a union rate (current union negotiated rate for local), a survey rate (weighted average rate) or a union average rate (weighted union average rate).

Union Rate Identifiers

A four letter classification abbreviation identifier enclosed in dotted lines beginning with characters other than ""SU"" or ""UAVG"" denotes that the union classification and rate were prevailing for that classification in the survey. Example: PLUM0198-005 07/01/2014. PLUM is an abbreviation identifier of the union which prevailed in the survey for this classification, which in this example would be Plumbers. 0198 indicates the local union number or district council number where applicable, i.e., Plumbers Local 0198. The next number, 005 in the example, is an internal number used in processing the wage determination. 07/01/2014 is the effective date of the most current negotiated rate, which in this example is July 1, 2014.

Union prevailing wage rates are updated to reflect all rate changes in the collective bargaining agreement (CBA) governing this classification and rate.

Survey Rate Identifiers

Classifications listed under the ""SU"" identifier indicate that no one rate prevailed for this classification in the survey and the published rate is derived by computing a weighted average rate based on all the rates reported in the survey for that classification. As this weighted average rate includes all rates reported in the survey, it may include both union and non-union rates. Example: SULA2012-007 5/13/2014. SU indicates the rates are survey rates based on a weighted average calculation of rates and are not majority rates. LA indicates the State of Louisiana. 2012 is the year of survey on which these classifications and rates are based. The next number, 007 in the example, is an internal number used in producing the wage determination. 5/13/2014 indicates the survey completion date for the classifications and rates under that identifier.

Survey wage rates are not updated and remain in effect until a

new survey is conducted.

Union Average Rate Identifiers

Classification(s) listed under the UAVG identifier indicate that no single majority rate prevailed for those classifications; however, 100% of the data reported for the classifications was union data. EXAMPLE: UAVG-OH-0010 08/29/2014. UAVG indicates that the rate is a weighted union average rate. OH indicates the state. The next number, 0010 in the example, is an internal number used in producing the wage determination. 08/29/2014 indicates the survey completion date for the classifications and rates under that identifier.

A UAVG rate will be updated once a year, usually in January of each year, to reflect a weighted average of the current negotiated/CBA rate of the union locals from which the rate is based.

WAGE DETERMINATION APPEALS PROCESS

1.) Has there been an initial decision in the matter? This can be:

- * an existing published wage determination
- * a survey underlying a wage determination
- * a Wage and Hour Division letter setting forth a position on a wage determination matter
- * a conformance (additional classification and rate) ruling

On survey related matters, initial contact, including requests for summaries of surveys, should be with the Wage and Hour National Office because National Office has responsibility for the Davis-Bacon survey program. If the response from this initial contact is not satisfactory, then the process described in 2.) and 3.) should be followed.

With regard to any other matter not yet ripe for the formal process described here, initial contact should be with the Branch of Construction Wage Determinations. Write to:

Branch of Construction Wage Determinations
Wage and Hour Division
U.S. Department of Labor
200 Constitution Avenue, N.W.
Washington, DC 20210

2.) If the answer to the question in 1.) is yes, then an interested party (those affected by the action) can request review and reconsideration from the Wage and Hour Administrator (See 29 CFR Part 1.8 and 29 CFR Part 7). Write to:

Wage and Hour Administrator
U.S. Department of Labor
200 Constitution Avenue, N.W.
Washington, DC 20210

The request should be accompanied by a full statement of the interested party's position and by any information (wage payment data, project description, area practice material,

etc.) that the requestor considers relevant to the issue.

3.) If the decision of the Administrator is not favorable, an interested party may appeal directly to the Administrative Review Board (formerly the Wage Appeals Board). Write to:

Administrative Review Board
U.S. Department of Labor
200 Constitution Avenue, N.W.
Washington, DC 20210

4.) All decisions by the Administrative Review Board are final.

=====
=

END OF GENERAL DECISION"

PART 1 - GENERAL PROVISIONS

Part 1 – General Contract Provisions

Section 10 Definition of Terms

When the following terms are used in these specifications, in the contract, or in any documents or other instruments pertaining to construction where these specifications govern, the intent and meaning shall be defined as follows:

Paragraph Number	Term	Definition
10-01	AASHTO	The American Association of State Highway and Transportation Officials.
10-02	Access Road	The right-of-way, the roadway and all improvements constructed thereon connecting the airport to a public roadway.
10-03	Advertisement	A public announcement, as required by local law, inviting bids for work to be performed and materials to be furnished.
10-04	Airport	Airport means an area of land or water which is used or intended to be used for the landing and takeoff of aircraft; an appurtenant area used or intended to be used for airport buildings or other airport facilities or rights of way; airport buildings and facilities located in any of these areas, and a heliport.
10-05	Airport Improvement Program (AIP)	A grant-in-aid program, administered by the Federal Aviation Administration (FAA).
10-06	Air Operations Area (AOA)	The term air operations area (AOA) shall mean any area of the airport used or intended to be used for the landing, takeoff, or surface maneuvering of aircraft. An air operation area shall include such paved or unpaved areas that are used or intended to be used for the unobstructed movement of aircraft in addition to its associated runway, taxiway, or apron.
10-07	Apron	Area where aircraft are parked, unloaded or loaded, fueled and/or serviced.
10-08	ASTM International (ASTM)	Formerly known as the American Society for Testing and Materials (ASTM).
10-09	Award	The Owner's notice to the successful bidder of the acceptance of the submitted bid.
10-10	Bidder	Any individual, partnership, firm, or corporation, acting directly or through a duly authorized representative, who submits a proposal for the work contemplated.

Paragraph Number	Term	Definition
10-11	Building Area	An area on the airport to be used, considered, or intended to be used for airport buildings or other airport facilities or rights-of-way together with all airport buildings and facilities located thereon.
10-12	Calendar Day	Every day shown on the calendar.
10-13	Certificate of Analysis (COA)	The COA is the manufacturer's Certificate of Compliance (COC) including all applicable test results required by the specifications.
10-14	Certificate of Compliance (COC)	The manufacturer's certification stating that materials or assemblies furnished fully comply with the requirements of the contract. The certificate shall be signed by the manufacturer's authorized representative.
10-15	Change Order	A written order to the Contractor covering changes in the plans, specifications, or proposal quantities and establishing the basis of payment and contract time adjustment, if any, for work within the scope of the contract and necessary to complete the project.
10-16	Contract	A written agreement between the Owner and the Contractor that establishes the obligations of the parties including but not limited to performance of work, furnishing of labor, equipment and materials and the basis of payment. The awarded contract includes but may not be limited to: Advertisement, Contract form, Proposal, Performance bond, payment bond, General provisions, certifications and representations, Technical Specifications, Plans, Supplemental Provisions, standards incorporated by reference and issued addenda.
10-17	Contract Item (Pay Item)	A specific unit of work for which a price is provided in the contract.
10-18	Contract Time	The number of calendar days or working days, stated in the proposal, allowed for completion of the contract, including authorized time extensions. If a calendar date of completion is stated in the proposal, in lieu of a number of calendar or working days, the contract shall be completed by that date.
10-19	Contractor	The individual, partnership, firm, or corporation primarily liable for the acceptable performance of the work contracted and for the payment of all legal debts pertaining to the work who acts directly or through lawful agents or employees to complete the contract work.
10-20	Contractors Quality Control (QC) Facilities	The Contractor's QC facilities in accordance with the Contractor Quality Control Program (CQCP).
10-21	Contractor Quality Control Program (CQCP)	Details the methods and procedures that will be taken to assure that all materials and completed construction required by the

Paragraph Number	Term	Definition
		contract conform to contract plans, technical specifications and other requirements, whether manufactured by the Contractor, or procured from subcontractors or vendors.
10-22	Control Strip	A demonstration by the Contractor that the materials, equipment, and construction processes results in a product meeting the requirements of the specification.
10-23	Construction Safety and Phasing Plan (CSPP)	The overall plan for safety and phasing of a construction project developed by the airport operator, or developed by the airport operator's consultant and approved by the airport operator. It is included in the invitation for bids and becomes part of the project specifications.
10-24	Drainage System	The system of pipes, ditches, and structures by which surface or subsurface waters are collected and conducted from the airport area.
10-25	Engineer	The individual, partnership, firm, or corporation duly authorized by the Owner to be responsible for engineering, inspection, and/or observation of the contract work and acting directly or through an authorized representative.
10-26	Equipment	All machinery, together with the necessary supplies for upkeep and maintenance; and all tools and apparatus necessary for the proper construction and acceptable completion of the work.
10-27	Extra Work	An item of work not provided for in the awarded contract as previously modified by change order or supplemental agreement, but which is found by the Owner's Engineer or Resident Project Representative (RPR) to be necessary to complete the work within the intended scope of the contract as previously modified.
10-28	FAA	The Federal Aviation Administration. When used to designate a person, FAA shall mean the Administrator or their duly authorized representative.
10-29	Federal Specifications	The federal specifications and standards, commercial item descriptions, and supplements, amendments, and indices prepared and issued by the General Services Administration.
10-30	Force Account	<p>a. Contract Force Account - A method of payment that addresses extra work performed by the Contractor on a time and material basis.</p> <p>b. Owner Force Account - Work performed for the project by the Owner's employees.</p>
10-31	Intention of Terms	Whenever, in these specifications or on the plans, the words "directed," "required," "permitted," "ordered," "designated," "prescribed," or words of like import are used, it shall be understood that the direction, requirement, permission, order, designation, or prescription of the Engineer and/or Resident

Paragraph Number	Term	Definition
		<p>Project Representative (RPR) is intended; and similarly, the words “approved,” “acceptable,” “satisfactory,” or words of like import, shall mean approved by, or acceptable to, or satisfactory to the Engineer and/or RPR, subject in each case to the final determination of the Owner.</p> <p>Any reference to a specific requirement of a numbered paragraph of the contract specifications or a cited standard shall be interpreted to include all general requirements of the entire section, specification item, or cited standard that may be pertinent to such specific reference.</p>
10-32	Lighting	A system of fixtures providing or controlling the light sources used on or near the airport or within the airport buildings. The field lighting includes all luminous signals, markers, floodlights, and illuminating devices used on or near the airport or to aid in the operation of aircraft landing at, taking off from, or taxiing on the airport surface.
10-33	Major and Minor Contract Items	A major contract item shall be any item that is listed in the proposal, the total cost of which is equal to or greater than 20% of the total amount of the award contract. All other items shall be considered minor contract items.
10-34	Materials	Any substance specified for use in the construction of the contract work.
10-35	Modification of Standards (MOS)	Any deviation from standard specifications applicable to material and construction methods in accordance with FAA Order 5300.1.
10-36	Notice to Proceed (NTP)	A written notice to the Contractor to begin the actual contract work on a previously agreed to date. If applicable, the Notice to Proceed shall state the date on which the contract time begins.
10-37	Owner	The term “Owner” shall mean the party of the first part or the contracting agency signatory to the contract. Where the term “Owner” is capitalized in this document, it shall mean airport Sponsor only.
10-38	Passenger Facility Charge (PFC)	Per 14 Code of Federal Regulations (CFR) Part 158 and 49 United States Code (USC) § 40117, a PFC is a charge imposed by a public agency on passengers enplaned at a commercial service airport it controls.
10-39	Pavement Structure	The combined surface course, base course(s), and subbase course(s), if any, considered as a single unit.
10-40	Payment bond	The approved form of security furnished by the Contractor and their own surety as a guaranty that the Contractor will pay in full all bills and accounts for materials and labor used in the construction of the work.

Paragraph Number	Term	Definition
10-41	Performance bond	The approved form of security furnished by the Contractor and their own surety as a guaranty that the Contractor will complete the work in accordance with the terms of the contract.
10-42	Plans	The official drawings or exact reproductions which show the location, character, dimensions and details of the airport and the work to be done and which are to be considered as a part of the contract, supplementary to the specifications. Plans may also be referred to as 'contract drawings.'
10-43	Project	The agreed scope of work for accomplishing specific airport development with respect to a particular airport.
10-44	Proposal	The written offer of the bidder (when submitted on the approved proposal form) to perform the contemplated work and furnish the necessary materials in accordance with the provisions of the plans and specifications.
10-45	Proposal guaranty	The security furnished with a proposal to guarantee that the bidder will enter into a contract if their own proposal is accepted by the Owner.
10-46	Quality Assurance (QA)	Owner's responsibility to assure that construction work completed complies with specifications for payment.
10-47	Quality Control (QC)	Contractor's responsibility to control material(s) and construction processes to complete construction in accordance with project specifications.
10-48	Quality Assurance (QA) Inspector	An authorized representative of the Engineer and/or Resident Project Representative (RPR) assigned to make all necessary inspections, observations, tests, and/or observation of tests of the work performed or being performed, or of the materials furnished or being furnished by the Contractor.
10-49	Quality Assurance (QA) Laboratory	The official quality assurance testing laboratories of the Owner or such other laboratories as may be designated by the Engineer or RPR. May also be referred to as Engineer's, Owner's, or QA Laboratory.
10-50	Resident Project Representative (RPR)	The individual, partnership, firm, or corporation duly authorized by the Owner to be responsible for all necessary inspections, observations, tests, and/or observations of tests of the contract work performed or being performed, or of the materials furnished or being furnished by the Contractor, and acting directly or through an authorized representative.
10-51	Runway	The area on the airport prepared for the landing and takeoff of aircraft.

Paragraph Number	Term	Definition
10-52	Runway Safety Area (RSA)	A defined surface surrounding the runway prepared or suitable for reducing the risk of damage to aircraft. See the construction safety and phasing plan (CSPP) for limits of the RSA.
10-53	Safety Plan Compliance Document (SPCD)	Details how the Contractor will comply with the CSPP.
10-54	Specifications	A part of the contract containing the written directions and requirements for completing the contract work. Standards for specifying materials or testing which are cited in the contract specifications by reference shall have the same force and effect as if included in the contract physically.
10-55	Sponsor	A Sponsor is defined in 49 USC § 47102(24) as a public agency that submits to the FAA for an AIP grant; or a private Owner of a public-use airport that submits to the FAA an application for an AIP grant for the airport.
10-56	Structures	Airport facilities such as bridges; culverts; catch basins, inlets, retaining walls, cribbing; storm and sanitary sewer lines; water lines; underdrains; electrical ducts, manholes, handholes, lighting fixtures and bases; transformers; navigational aids; buildings; vaults; and, other manmade features of the airport that may be encountered in the work and not otherwise classified herein.
10-57	Subgrade	The soil that forms the pavement foundation.
10-58	Superintendent	The Contractor's executive representative who is present on the work during progress, authorized to receive and fulfill instructions from the RPR, and who shall supervise and direct the construction.
10-59	Supplemental Agreement	A written agreement between the Contractor and the Owner that establishes the basis of payment and contract time adjustment, if any, for the work affected by the supplemental agreement. A supplemental agreement is required if: (1) in scope work would increase or decrease the total amount of the awarded contract by more than 25%; (2) in scope work would increase or decrease the total of any major contract item by more than 25%; (3) work that is not within the scope of the originally awarded contract; or (4) adding or deleting of a major contract item.
10-60	Surety	The corporation, partnership, or individual, other than the Contractor, executing payment or performance bonds that are furnished to the Owner by the Contractor.
10-61	Taxilane	A taxiway designed for low speed movement of aircraft between aircraft parking areas and terminal areas.
10-62	Taxiway	The portion of the air operations area of an airport that has been designated by competent airport authority for movement of

Paragraph Number	Term	Definition
		aircraft to and from the airport's runways, aircraft parking areas, and terminal areas.
10-63	Taxiway/Taxilane Safety Area (TSA)	A defined surface alongside the taxiway prepared or suitable for reducing the risk of damage to an aircraft. See the construction safety and phasing plan (CSPP) for limits of the TSA.
10-64	Work	The furnishing of all labor, materials, tools, equipment, and incidentals necessary or convenient to the Contractor's performance of all duties and obligations imposed by the contract, plans, and specifications.
10-65	Working day	A working day shall be any day other than a legal holiday, Saturday, or Sunday on which the normal working forces of the Contractor may proceed with regular work for at least six (6) hours toward completion of the contract. When work is suspended for causes beyond the Contractor's control, it will not be counted as a working day. Saturdays, Sundays and holidays on which the Contractor's forces engage in regular work will be considered as working days.
10-66	Owner Defined terms	<p>[None]</p> <p>*****</p> <p>The Engineer may add and define additional terms, if necessary.</p> <p>On projects that utilize a Construction Manager (CM), a Construction Manager at Risk (CMAR), or a Construction Manager/General Contractor (CMGC), add a definition of their roles on the project. The CM generally acts as an agent of the owner and is not legally or financially responsible for completion of the work; a CMAR and CMGC are legally and financially obligated to complete the work.</p> <p>*****</p>

END OF SECTION 10

Section 20 Proposal Requirements and Conditions

20-01 Advertisement (Notice to Bidders). See advertisement included in specifications book.

20-02 Qualification of bidders. Each bidder shall submit evidence of competency and evidence of financial responsibility to perform the work to the Owner at the time of bid opening.

Evidence of competency, unless otherwise specified, shall consist of statements covering the bidder's past experience on similar work, and a list of equipment and a list of key personnel that would be available for the work.

Each bidder shall furnish the Owner satisfactory evidence of their financial responsibility. Evidence of financial responsibility, unless otherwise specified, shall consist of a confidential statement or report of the bidder's financial resources and liabilities as of the last calendar year or the bidder's last fiscal year. Such statements or reports shall be certified by a public accountant. At the time of submitting such financial statements or reports, the bidder shall further certify whether their financial responsibility is approximately the same as stated or reported by the public accountant. If the bidder's financial responsibility has changed, the bidder shall qualify the public accountant's statement or report to reflect the bidder's true financial condition at the time such qualified statement or report is submitted to the Owner.

Unless otherwise specified, a bidder may submit evidence that they are prequalified with the State Highway Division and are on the current "bidder's list" of the state in which the proposed work is located. Evidence of State Highway Division prequalification may be submitted as evidence of financial responsibility in lieu of the certified statements or reports specified above.

20-03 Contents of proposal forms. The Owner's proposal forms state the location and description of the proposed construction; the place, date, and time of opening of the proposals; and the estimated quantities of the various items of work to be performed and materials to be furnished for which unit bid prices are asked. The proposal form states the time in which the work must be completed, and the amount of the proposal guaranty that must accompany the proposal. The Owner will accept only those Proposals properly executed on physical forms or electronic forms provided by the Owner. Bidder actions that may cause the Owner to deem a proposal irregular are given in paragraph 20-09 *Irregular proposals*.

Mobilization is limited to 10 percent of the total project cost.

20-04 Issuance of proposal forms. The Owner reserves the right to refuse to issue a proposal form to a prospective bidder if the bidder is in default for any of the following reasons:

- a. Failure to comply with any prequalification regulations of the Owner, if such regulations are cited, or otherwise included, in the proposal as a requirement for bidding.
- b. Failure to pay, or satisfactorily settle, all bills due for labor and materials on former contracts in force with the Owner at the time the Owner issues the proposal to a prospective bidder.
- c. Documented record of Contractor default under previous contracts with the Owner.
- d. Documented record of unsatisfactory work on previous contracts with the Owner.

20-05 Interpretation of estimated proposal quantities. An estimate of quantities of work to be done and materials to be furnished under these specifications is given in the proposal. It is the result of careful calculations and is believed to be correct. It is given only as a basis for comparison of proposals and the award of the contract. The Owner does not expressly, or by implication, agree that the actual quantities

involved will correspond exactly therewith; nor shall the bidder plead misunderstanding or deception because of such estimates of quantities, or of the character, location, or other conditions pertaining to the work. Payment to the Contractor will be made only for the actual quantities of work performed or materials furnished in accordance with the plans and specifications. It is understood that the quantities may be increased or decreased as provided in the Section 40, paragraph 40-02, Alteration of Work and Quantities, without in any way invalidating the unit bid prices.

20-06 Examination of plans, specifications, and site. The bidder is expected to carefully examine the site of the proposed work, the proposal, plans, specifications, and contract forms. Bidders shall satisfy themselves to the character, quality, and quantities of work to be performed, materials to be furnished, and to the requirements of the proposed contract. The submission of a proposal shall be prima facie evidence that the bidder has made such examination and is satisfied to the conditions to be encountered in performing the work and the requirements of the proposed contract, plans, and specifications.

Boring logs and other records of subsurface investigations and tests may be available for inspection of bidders. It is understood and agreed that such subsurface information, whether included in the plans, specifications, or otherwise made available to the bidder, was obtained and is intended for the Owner's design and estimating purposes only. Such information has been made available for the convenience of all bidders. It is further understood and agreed that each bidder is solely responsible for all assumptions, deductions, or conclusions which the bidder may make or obtain from their own examination of the boring logs and other records of subsurface investigations and tests that are furnished by the Owner.

20-07 Preparation of proposal. The bidder shall submit their proposal on the forms furnished by the Owner. All blank spaces in the proposal forms, unless explicitly stated otherwise, must be correctly filled in where indicated for each and every item for which a quantity is given. The bidder shall state the price (written in ink or typed) both in words and numerals which they propose for each pay item furnished in the proposal. In case of conflict between words and numerals, the words, unless obviously incorrect, shall govern.

The bidder shall correctly sign the proposal in ink. If the proposal is made by an individual, their name and post office address must be shown. If made by a partnership, the name and post office address of each member of the partnership must be shown. If made by a corporation, the person signing the proposal shall give the name of the state where the corporation was chartered and the name, titles, and business address of the president, secretary, and the treasurer. Anyone signing a proposal as an agent shall file evidence of their authority to do so and that the signature is binding upon the firm or corporation.

20-08 Responsive and responsible bidder. A responsive bid conforms to all significant terms and conditions contained in the Owner's invitation for bid. It is the Owner's responsibility to decide if the exceptions taken by a bidder to the solicitation are material or not and the extent of deviation it is willing to accept.

A responsible bidder has the ability to perform successfully under the terms and conditions of a proposed procurement, as defined in 2 CFR § 200.318(h). This includes such matters as Contractor integrity, compliance with public policy, record of past performance, and financial and technical resources.

20-09 Irregular proposals. Proposals shall be considered irregular for the following reasons:

- a. If the proposal is on a form other than that furnished by the Owner, or if the Owner's form is altered, or if any part of the proposal form is detached.
- b. If there are unauthorized additions, conditional or alternate pay items, or irregularities of any kind that make the proposal incomplete, indefinite, or otherwise ambiguous.
- c. If the proposal does not contain a unit price for each pay item listed in the proposal, except in the case of authorized alternate pay items, for which the bidder is not required to furnish a unit price.
- d. If the proposal contains unit prices that are obviously unbalanced.

- e. If the proposal is not accompanied by the proposal guaranty specified by the Owner.
- f. If the applicable Disadvantaged Business Enterprise information is incomplete.

The Owner reserves the right to reject any irregular proposal and the right to waive technicalities if such waiver is in the best interest of the Owner and conforms to local laws and ordinances pertaining to the letting of construction contracts.

20-10 Bid guarantee. Each separate proposal shall be accompanied by a bid bond, certified check, or other specified acceptable collateral, in the amount specified in the proposal form. Such bond, check, or collateral, shall be made payable to the Owner.

20-11 Delivery of proposal. Each proposal submitted shall be placed in a sealed envelope plainly marked with the project number, location of airport, and name and business address of the bidder on the outside. When sent by mail, preferably registered, the sealed proposal, marked as indicated above, should be enclosed in an additional envelope. No proposal will be considered unless received at the place specified in the advertisement or as modified by Addendum before the time specified for opening all bids. Proposals received after the bid opening time shall be returned to the bidder unopened.

20-12 Withdrawal or revision of proposals. A bidder may withdraw or revise (by withdrawal of one proposal and submission of another) a proposal provided that the bidder's request for withdrawal is received by the Owner in writing, by fax or by email before the time specified for opening bids. Revised proposals must be received at the place specified in the advertisement before the time specified for opening all bids.

20-13 Public opening of proposals. Proposals shall be opened, and read, publicly at the time and place specified in the advertisement. Bidders, their authorized agents, and other interested persons are invited to attend. Proposals that have been withdrawn (by written or telegraphic request) or received after the time specified for opening bids shall be returned to the bidder unopened.

20-14 Disqualification of bidders. A bidder shall be considered disqualified for any of the following reasons:

- a. Submitting more than one proposal from the same partnership, firm, or corporation under the same or different name.

- b. Evidence of collusion among bidders. Bidders participating in such collusion shall be disqualified as bidders for any future work of the Owner until any such participating bidder has been reinstated by the Owner as a qualified bidder.

- c. If the bidder is considered to be in "default" for any reason specified in paragraph 20-04, *Issuance of Proposal Forms*, of this section.

20-15 Discrepancies and Omissions. A Bidder who discovers discrepancies or omissions with the project bid documents shall immediately notify the Owner's Engineer of the matter. A bidder that has doubt as to the true meaning of a project requirement may submit to the Owner's Engineer a written request for interpretation no later than 2 days prior to bid opening.

Any interpretation of the project bid documents by the Owner's Engineer will be by written addendum issued by the Owner. The Owner will not consider any instructions, clarifications or interpretations of the bidding documents in any manner other than written addendum.

END OF SECTION 20

Page Intentionally Blank

Section 30 Award and Execution of Contract

30-01 Consideration of proposals. After the proposals are publicly opened and read, they will be compared on the basis of the summation of the products obtained by multiplying the estimated quantities shown in the proposal by the unit bid prices. If a bidder's proposal contains a discrepancy between unit bid prices written in words and unit bid prices written in numbers, the unit bid price written in words shall govern.

Until the award of a contract is made, the Owner reserves the right to reject a bidder's proposal for any of the following reasons:

a. If the proposal is irregular as specified in Section 20, paragraph 20-09, *Irregular Proposals*.

b. If the bidder is disqualified for any of the reasons specified Section 20, paragraph 20-14, *Disqualification of Bidders*.

In addition, until the award of a contract is made, the Owner reserves the right to reject any or all proposals, waive technicalities, if such waiver is in the best interest of the Owner and is in conformance with applicable state and local laws or regulations pertaining to the letting of construction contracts; advertise for new proposals; or proceed with the work otherwise. All such actions shall promote the Owner's best interests.

30-02 Award of contract. The award of a contract, if it is to be awarded, shall be made within 60-120 calendar days of the date specified for publicly opening proposals, unless otherwise specified herein.

If the Owner elects to proceed with an award of contract, the Owner will make award to the responsible bidder whose bid, conforming with all the material terms and conditions of the bid documents, is the lowest in price.

30-03 Cancellation of award. The Owner reserves the right to cancel the award without liability to the bidder, except return of proposal guaranty, at any time before a contract has been fully executed by all parties and is approved by the Owner in accordance with paragraph 30-07 *Approval of Contract*.

30-04 Return of proposal guaranty. All proposal guaranties, except those of the two lowest bidders, will be returned immediately after the Owner has made a comparison of bids as specified in the paragraph 30-01, *Consideration of Proposals*. Proposal guaranties of the two lowest bidders will be retained by the Owner until such time as an award is made, at which time, the unsuccessful bidder's proposal guaranty will be returned. The successful bidder's proposal guaranty will be returned as soon as the Owner receives the contract bonds as specified in paragraph 30-05, *Requirements of Contract Bonds*.

30-05 Requirements of contract bonds. At the time of the execution of the contract, the successful bidder shall furnish the Owner a surety bond or bonds that have been fully executed by the bidder and the surety guaranteeing the performance of the work and the payment of all legal debts that may be incurred by reason of the Contractor's performance of the work. The surety and the form of the bond or bonds shall be acceptable to the Owner. Unless otherwise specified in this subsection, the surety bond or bonds shall be in a sum equal to the full amount of the contract.

30-06 Execution of contract. The successful bidder shall sign (execute) the necessary agreements for entering into the contract and return the signed contract to the Owner, along with the fully executed surety bond or bonds specified in paragraph 30-05, *Requirements of Contract Bonds*, of this section, within 10 calendar days from the date mailed or otherwise delivered to the successful bidder.

30-07 Approval of contract. Upon receipt of the contract and contract bond or bonds that have been executed by the successful bidder, the Owner shall complete the execution of the contract in accordance with local laws or ordinances, and return the fully executed contract to the Contractor. Delivery of the fully executed contract to the Contractor shall constitute the Owner's approval to be bound by the successful bidder's proposal and the terms of the contract.

30-08 Failure to execute contract. Failure of the successful bidder to execute the contract and furnish an acceptable surety bond or bonds within the period specified in paragraph 30-06, *Execution of Contract*, of this section shall be just cause for cancellation of the award and forfeiture of the proposal guaranty, not as a penalty, but as liquidated damages to the Owner.

END OF SECTION 30

Page Intentionally Blank

Section 40 Scope of Work

40-01 Intent of contract. The intent of the contract is to provide for construction and completion, in every detail, of the work described. It is further intended that the Contractor shall furnish all labor, materials, equipment, tools, transportation, and supplies required to complete the work in accordance with the plans, specifications, and terms of the contract.

40-02 Alteration of work and quantities. The Owner reserves the right to make such changes in quantities and work as may be necessary or desirable to complete, in a satisfactory manner, the original intended work. Unless otherwise specified in the Contract, the Owner's Engineer or RPR shall be and is hereby authorized to make, in writing, such in-scope alterations in the work and variation of quantities as may be necessary to complete the work, provided such action does not represent a significant change in the character of the work.

For purpose of this section, a significant change in character of work means: any change that is outside the current contract scope of work; any change (increase or decrease) in the total contract cost by more than 25%; or any change in the total cost of a major contract item by more than 25%.

Work alterations and quantity variances that do not meet the definition of significant change in character of work shall not invalidate the contract nor release the surety. Contractor agrees to accept payment for such work alterations and quantity variances in accordance with Section 90, paragraph 90-03, *Compensation for Altered Quantities*.

Should the value of altered work or quantity variance meet the criteria for significant change in character of work, such altered work and quantity variance shall be covered by a supplemental agreement. Supplemental agreements shall also require consent of the Contractor's surety and separate performance and payment bonds. If the Owner and the Contractor are unable to agree on a unit adjustment for any contract item that requires a supplemental agreement, the Owner reserves the right to terminate the contract with respect to the item and make other arrangements for its completion.

40-03 Omitted items. The Owner, the Owner's Engineer or the RPR may provide written notice to the Contractor to omit from the work any contract item that does not meet the definition of major contract item. Major contract items may be omitted by a supplemental agreement. Such omission of contract items shall not invalidate any other contract provision or requirement.

Should a contract item be omitted or otherwise ordered to be non-performed, the Contractor shall be paid for all work performed toward completion of such item prior to the date of the order to omit such item. Payment for work performed shall be in accordance with Section 90, paragraph 90-04, *Payment for Omitted Items*.

40-04 Extra work. Should acceptable completion of the contract require the Contractor to perform an item of work not provided for in the awarded contract as previously modified by change order or supplemental agreement, Owner may issue a Change Order to cover the necessary extra work. Change orders for extra work shall contain agreed unit prices for performing the change order work in accordance with the requirements specified in the order, and shall contain any adjustment to the contract time that, in the RPR's opinion, is necessary for completion of the extra work.

When determined by the RPR to be in the Owner's best interest, the RPR may order the Contractor to proceed with extra work as provided in Section 90, paragraph 90-05, *Payment for Extra Work*. Extra work that is necessary for acceptable completion of the project, but is not within the general scope of the work

covered by the original contract shall be covered by a supplemental agreement as defined in Section 10, paragraph 10-59, *Supplemental Agreement*.

If extra work is essential to maintaining the project critical path, RPR may order the Contractor to commence the extra work under a Time and Material contract method. Once sufficient detail is available to establish the level of effort necessary for the extra work, the Owner shall initiate a change order or supplemental agreement to cover the extra work.

Any claim for payment of extra work that is not covered by written agreement (change order or supplemental agreement) shall be rejected by the Owner.

40-05 Maintenance of traffic. It is the explicit intention of the contract that the safety of aircraft, as well as the Contractor's equipment and personnel, is the most important consideration. The Contractor shall maintain traffic in the manner detailed in the Construction Safety and Phasing Plan (CSPP).

a. It is understood and agreed that the Contractor shall provide for the free and unobstructed movement of aircraft in the air operations areas (AOAs) of the airport with respect to their own operations and the operations of all subcontractors as specified in Section 80, paragraph 80-04, *Limitation of Operations*. It is further understood and agreed that the Contractor shall provide for the uninterrupted operation of visual and electronic signals (including power supplies thereto) used in the guidance of aircraft while operating to, from, and upon the airport as specified in Section 70, paragraph 70-15, *Contractor's Responsibility for Utility Service and Facilities of Others*.

b. With respect to their own operations and the operations of all subcontractors, the Contractor shall provide marking, lighting, and other acceptable means of identifying personnel, equipment, vehicles, storage areas, and any work area or condition that may be hazardous to the operation of aircraft, fire-rescue equipment, or maintenance vehicles at the airport in accordance with the construction safety and phasing plan (CSPP) and the safety plan compliance document (SPCD).

c. When the contract requires the maintenance of an existing road, street, or highway during the Contractor's performance of work that is otherwise provided for in the contract, plans, and specifications, the Contractor shall keep the road, street, or highway open to all traffic and shall provide maintenance as may be required to accommodate traffic. The Contractor, at their expense, shall be responsible for the repair to equal or better than preconstruction conditions of any damage caused by the Contractor's equipment and personnel. The Contractor shall furnish, erect, and maintain barricades, warning signs, flag person, and other traffic control devices in reasonable conformity with the Manual on Uniform Traffic Control Devices (MUTCD) (<http://mutcd.fhwa.dot.gov/>), unless otherwise specified. The Contractor shall also construct and maintain in a safe condition any temporary connections necessary for ingress to and egress from abutting property or intersecting roads, streets or highways. Unless otherwise specified herein, the Contractor will not be required to furnish snow removal for such existing road, street, or highway.

40-06 Removal of existing structures. All existing structures encountered within the established lines, grades, or grading sections shall be removed by the Contractor, unless such existing structures are otherwise specified to be relocated, adjusted up or down, salvaged, abandoned in place, reused in the work or to remain in place. The cost of removing such existing structures shall not be measured or paid for directly but shall be included in the various contract items.

Should the Contractor encounter an existing structure (above or below ground) in the work for which the disposition is not indicated on the plans, the Resident Project Representative (RPR) shall be notified prior to disturbing such structure. The disposition of existing structures so encountered shall be immediately determined by the RPR in accordance with the provisions of the contract.

Except as provided in Section 40, paragraph 40-07, *Rights in and Use of Materials Found in the Work*, it is intended that all existing materials or structures that may be encountered (within the lines, grades, or

grading sections established for completion of the work) shall be used in the work as otherwise provided for in the contract and shall remain the property of the Owner when so used in the work.

40-07 Rights in and use of materials found in the work. Should the Contractor encounter any material such as (but not restricted to) sand, stone, gravel, slag, or concrete slabs within the established lines, grades, or grading sections, the use of which is intended by the terms of the contract to be embankment, the Contractor may at their own option either:

a. Use such material in another contract item, providing such use is approved by the RPR and is in conformance with the contract specifications applicable to such use; or,

b. Remove such material from the site, upon written approval of the RPR; or

c. Use such material for the Contractor's own temporary construction on site; or,

d. Use such material as intended by the terms of the contract.

Should the Contractor wish to exercise option a., b., or c., the Contractor shall request the RPR's approval in advance of such use.

Should the RPR approve the Contractor's request to exercise option a., b., or c., the Contractor shall be paid for the excavation or removal of such material at the applicable contract price. The Contractor shall replace, at their expense, such removed or excavated material with an agreed equal volume of material that is acceptable for use in constructing embankment, backfills, or otherwise to the extent that such replacement material is needed to complete the contract work. The Contractor shall not be charged for use of such material used in the work or removed from the site.

Should the RPR approve the Contractor's exercise of option a., the Contractor shall be paid, at the applicable contract price, for furnishing and installing such material in accordance with requirements of the contract item in which the material is used.

It is understood and agreed that the Contractor shall make no claim for delays by reason of their own exercise of option a., b., or c.

The Contractor shall not excavate, remove, or otherwise disturb any material, structure, or part of a structure which is located outside the lines, grades, or grading sections established for the work, except where such excavation or removal is provided for in the contract, plans, or specifications.

40-08 Final cleanup. Upon completion of the work and before acceptance and final payment will be made, the Contractor shall remove from the site all machinery, equipment, surplus and discarded materials, rubbish, temporary structures, and stumps or portions of trees. The Contractor shall cut all brush and woods within the limits indicated and shall leave the site in a neat and presentable condition. Material cleared from the site and deposited on adjacent property will not be considered as having been disposed of satisfactorily, unless the Contractor has obtained the written permission of the property Owner.

END OF SECTION 40

Section 50 Control of Work

50-01 Authority of the Resident Project Representative (RPR). The RPR has final authority regarding the interpretation of project specification requirements. The RPR shall determine acceptability of the quality of materials furnished, method of performance of work performed, and the manner and rate of performance of the work. The RPR does not have the authority to accept work that does not conform to specification requirements.

50-02 Conformity with plans and specifications. All work and all materials furnished shall be in reasonably close conformity with the lines, grades, grading sections, cross-sections, dimensions, material requirements, and testing requirements that are specified (including specified tolerances) in the contract, plans, or specifications.

If the RPR finds the materials furnished, work performed, or the finished product not within reasonably close conformity with the plans and specifications, but that the portion of the work affected will, in their opinion, result in a finished product having a level of safety, economy, durability, and workmanship acceptable to the Owner, the RPR will advise the Owner of their determination that the affected work be accepted and remain in place. The RPR will document the determination and recommend to the Owner a basis of acceptance that will provide for an adjustment in the contract price for the affected portion of the work. Changes in the contract price must be covered by contract change order or supplemental agreement as applicable.

If the RPR finds the materials furnished, work performed, or the finished product are not in reasonably close conformity with the plans and specifications and have resulted in an unacceptable finished product, the affected work or materials shall be removed and replaced or otherwise corrected by and at the expense of the Contractor in accordance with the RPR's written orders.

The term "reasonably close conformity" shall not be construed as waiving the Contractor's responsibility to complete the work in accordance with the contract, plans, and specifications. The term shall not be construed as waiving the RPR's responsibility to insist on strict compliance with the requirements of the contract, plans, and specifications during the Contractor's execution of the work, when, in the RPR's opinion, such compliance is essential to provide an acceptable finished portion of the work.

The term "reasonably close conformity" is also intended to provide the RPR with the authority, after consultation with the Sponsor and FAA, to use sound engineering judgment in their determinations to accept work that is not in strict conformity, but will provide a finished product equal to or better than that required by the requirements of the contract, plans and specifications.

The RPR will not be responsible for the Contractor's means, methods, techniques, sequences, or procedures of construction or the safety precautions incident thereto.

50-03 Coordination of contract, plans, and specifications. The contract, plans, specifications, and all referenced standards cited are essential parts of the contract requirements. If electronic files are provided and used on the project and there is a conflict between the electronic files and hard copy plans, the hard copy plans shall govern. A requirement occurring in one is as binding as though occurring in all. They are intended to be complementary and to describe and provide for a complete work. In case of discrepancy, calculated dimensions will govern over scaled dimensions; contract technical specifications shall govern over contract general provisions, plans, cited standards for materials or testing, and cited advisory circulars (ACs); contract general provisions shall govern over plans, cited standards for materials or testing, and cited ACs; plans shall govern over cited standards for materials or testing and cited ACs. If

any paragraphs contained in the Special Provisions conflict with General Provisions or Technical Specifications, the Special Provisions shall govern.

From time to time, discrepancies within cited testing standards occur due to the timing of the change, edits, and/or replacement of the standards. If the Contractor discovers any apparent discrepancy within standard test methods, the Contractor shall immediately ask the RPR for an interpretation and decision, and such decision shall be final.

The Contractor shall not take advantage of any apparent error or omission on the plans or specifications. In the event the Contractor discovers any apparent error or discrepancy, Contractor shall immediately notify the Owner or the designated representative in writing requesting their written interpretation and decision.

50-04 List of Special Provisions. See Special Provisions Table of Contents.

50-05 Cooperation of Contractor. The Contractor shall be supplied with [five] hard copies or an electronic PDF of the plans and specifications. The Contractor shall have available on the construction site at all times one hardcopy each of the plans and specifications. Additional hard copies of plans and specifications may be obtained by the Contractor for the cost of reproduction.

The Contractor shall give constant attention to the work to facilitate the progress thereof, and shall cooperate with the RPR and their inspectors and with other Contractors in every way possible. The Contractor shall have a competent superintendent on the work at all times who is fully authorized as their agent on the work. The superintendent shall be capable of reading and thoroughly understanding the plans and specifications and shall receive and fulfill instructions from the RPR or their authorized representative.

50-06 Cooperation between Contractors. The Owner reserves the right to contract for and perform other or additional work on or near the work covered by this contract.

When separate contracts are let within the limits of any one project, each Contractor shall conduct the work not to interfere with or hinder the progress of completion of the work being performed by other Contractors. Contractors working on the same project shall cooperate with each other as directed.

Each Contractor involved shall assume all liability, financial or otherwise, in connection with their own contract and shall protect and hold harmless the Owner from any and all damages or claims that may arise because of inconvenience, delays, or loss experienced because of the presence and operations of other Contractors working within the limits of the same project.

The Contractor shall arrange their work and shall place and dispose of the materials being used to not interfere with the operations of the other Contractors within the limits of the same project. The Contractor shall join their work with that of the others in an acceptable manner and shall perform it in proper sequence to that of the others.

50-07 Construction layout and stakes. The Engineer/RPR shall establish necessary horizontal and vertical control. The establishment of Survey Control and/or reestablishment of survey control shall be by a State Licensed Land Surveyor. Contractor is responsible for preserving integrity of horizontal and vertical controls established by Engineer/RPR. In case of negligence on the part of the Contractor or their employees, resulting in the destruction of any horizontal and vertical control, the resulting costs will be deducted as a liquidated damage against the Contractor.

Prior to the start of construction, the Contractor will check all control points for horizontal and vertical accuracy and certify in writing to the RPR that the Contractor concurs with survey control established for the project. All lines, grades and measurements from control points necessary for the proper execution and control of the work on this project will be provided to the RPR. The Contractor is responsible to establish all layout required for the construction of the project.

Copies of survey notes will be provided to the RPR for each area of construction and for each placement of material as specified to allow the RPR to make periodic checks for conformance with plan grades, alignments and grade tolerances required by the applicable material specifications. Surveys will be provided to the RPR prior to commencing work items that cover or disturb the survey staking. Survey(s) and notes shall be provided in the following format(s): CAD files and hardcopy.

Laser, GPS, String line, or other automatic control shall be checked with temporary control as necessary. In the case of error, on the part of the Contractor, their surveyor, employees or subcontractors, resulting in established grades, alignment or grade tolerances that do not concur with those specified or shown on the plans, the Contractor is solely responsible for correction, removal, replacement and all associated costs at no additional cost to the Owner.

No direct payment will be made, unless otherwise specified in contract documents, for this labor, materials, or other expenses. The cost shall be included in the price of the bid for the various items of the Contract.

50-08 Authority and duties of Quality Assurance (QA) inspectors. QA inspectors shall be authorized to inspect all work done and all material furnished. Such QA inspection may extend to all or any part of the work and to the preparation, fabrication, or manufacture of the materials to be used. QA inspectors are not authorized to revoke, alter, or waive any provision of the contract. QA inspectors are not authorized to issue instructions contrary to the plans and specifications or to act as foreman for the Contractor.

QA Inspectors are authorized to notify the Contractor or their representatives of any failure of the work or materials to conform to the requirements of the contract, plans, or specifications and to reject such nonconforming materials in question until such issues can be referred to the RPR for a decision.

50-09 Inspection of the work. All materials and each part or detail of the work shall be subject to inspection. The RPR shall be allowed access to all parts of the work and shall be furnished with such information and assistance by the Contractor as is required to make a complete and detailed inspection.

If the RPR requests it, the Contractor, at any time before acceptance of the work, shall remove or uncover such portions of the finished work as may be directed. After examination, the Contractor shall restore said portions of the work to the standard required by the specifications. Should the work thus exposed or examined prove acceptable, the uncovering, or removing, and the replacing of the covering or making good of the parts removed will be paid for as extra work; but should the work so exposed or examined prove unacceptable, the uncovering, or removing, and the replacing of the covering or making good of the parts removed will be at the Contractor's expense.

Provide advance written notice to the RPR of work the Contractor plans to perform each week and each day. Any work done or materials used without written notice and allowing opportunity for inspection by the RPR may be ordered removed and replaced at the Contractor's expense.

Should the contract work include relocation, adjustment, or any other modification to existing facilities, not the property of the (contract) Owner, authorized representatives of the Owners of such facilities shall have the right to inspect such work. Such inspection shall in no sense make any facility owner a party to the contract, and shall in no way interfere with the rights of the parties to this contract.

50-10 Removal of unacceptable and unauthorized work. All work that does not conform to the requirements of the contract, plans, and specifications will be considered unacceptable, unless otherwise determined acceptable by the RPR as provided in paragraph 50-02, *Conformity with Plans and Specifications*.

Unacceptable work, whether the result of poor workmanship, use of defective materials, damage through carelessness, or any other cause found to exist prior to the final acceptance of the work, shall be removed immediately and replaced in an acceptable manner in accordance with the provisions of Section 70, paragraph 70-14, *Contractor's Responsibility for Work*.

No removal work made under provision of this paragraph shall be done without lines and grades having been established by the RPR. Work done contrary to the instructions of the RPR, work done beyond the lines shown on the plans or as established by the RPR, except as herein specified, or any extra work done without authority, will be considered as unauthorized and will not be paid for under the provisions of the contract. Work so done may be ordered removed or replaced at the Contractor's expense.

Upon failure on the part of the Contractor to comply with any order of the RPR made under the provisions of this subsection, the RPR will have authority to cause unacceptable work to be remedied or removed and replaced; and unauthorized work to be removed and recover the resulting costs as a liquidated damage against the Contractor.

50-11 Load restrictions. The Contractor shall comply with all legal load restrictions in the hauling of materials on public roads beyond the limits of the work. A special permit will not relieve the Contractor of liability for damage that may result from the moving of material or equipment.

The operation of equipment of such weight or so loaded as to cause damage to structures or to any other type of construction will not be permitted. Hauling of materials over the base course or surface course under construction shall be limited as directed. No loads will be permitted on a concrete pavement, base, or structure before the expiration of the curing period. The Contractor, at their own expense, shall be responsible for the repair to equal or better than preconstruction conditions of any damage caused by the Contractor's equipment and personnel.

50-12 Maintenance during construction. The Contractor shall maintain the work during construction and until the work is accepted. Maintenance shall constitute continuous and effective work prosecuted day by day, with adequate equipment and forces so that the work is maintained in satisfactory condition at all times.

In the case of a contract for the placing of a course upon a course or subgrade previously constructed, the Contractor shall maintain the previous course or subgrade during all construction operations.

All costs of maintenance work during construction and before the project is accepted shall be included in the unit prices bid on the various contract items, and the Contractor will not be paid an additional amount for such work.

50-13 Failure to maintain the work. Should the Contractor at any time fail to maintain the work as provided in paragraph 50-12, *Maintenance during Construction*, the RPR shall immediately notify the Contractor of such noncompliance. Such notification shall specify a reasonable time within which the Contractor shall be required to remedy such unsatisfactory maintenance condition. The time specified will give due consideration to the exigency that exists.

Should the Contractor fail to respond to the RPR's notification, the Owner may suspend any work necessary for the Owner to correct such unsatisfactory maintenance condition, depending on the exigency that exists. Any maintenance cost incurred by the Owner, shall be recovered as a liquidated damage against the Contractor.

50-14 Partial acceptance. If at any time during the execution of the project the Contractor substantially completes a usable unit or portion of the work, the occupancy of which will benefit the Owner, the Contractor may request the RPR to make final inspection of that unit. If the RPR finds upon inspection that the unit has been satisfactorily completed in compliance with the contract, the RPR may accept it as being complete, and the Contractor may be relieved of further responsibility for that unit. Such partial acceptance and beneficial occupancy by the Owner shall not void or alter any provision of the contract.

50-15 Final acceptance. Upon due notice from the Contractor of presumptive completion of the entire project, the RPR and Owner will make an inspection. If all construction provided for and contemplated by the contract is found to be complete in accordance with the contract, plans, and specifications, such

inspection shall constitute the final inspection. The RPR shall notify the Contractor in writing of final acceptance as of the date of the final inspection.

If, however, the inspection discloses any work, in whole or in part, as being unsatisfactory, the RPR will notify the Contractor and the Contractor shall correct the unsatisfactory work. Upon correction of the work, another inspection will be made which shall constitute the final inspection, provided the work has been satisfactorily completed. In such event, the RPR will make the final acceptance and notify the Contractor in writing of this acceptance as of the date of final inspection.

50-16 Claims for adjustment and disputes. If for any reason the Contractor deems that additional compensation is due for work or materials not clearly provided for in the contract, plans, or specifications or previously authorized as extra work, the Contractor shall notify the RPR in writing of their intention to claim such additional compensation before the Contractor begins the work on which the Contractor bases the claim. If such notification is not given or the RPR is not afforded proper opportunity by the Contractor for keeping strict account of actual cost as required, then the Contractor hereby agrees to waive any claim for such additional compensation. Such notice by the Contractor and the fact that the RPR has kept account of the cost of the work shall not in any way be construed as proving or substantiating the validity of the claim. When the work on which the claim for additional compensation is based has been completed, the Contractor shall, within 10 calendar days, submit a written claim to the RPR who will present it to the Owner for consideration in accordance with local laws or ordinances.

Nothing in this subsection shall be construed as a waiver of the Contractor's right to dispute final payment based on differences in measurements or computations.

50-17 Value Engineering Cost Proposal.

The provisions of this paragraph will apply only to contracts awarded to the lowest bidder pursuant to competitive bidding.

On projects with original contract amounts in excess of \$100,000, the Contractor may submit to the RPR, in writing, proposals for modifying the plans, specifications or other requirements of the contract for the sole purpose of reducing the cost of construction. The value engineering cost proposal shall not impair, in any manner, the essential functions or characteristics of the project, including but not limited to service life, economy of operation, ease of maintenance, desired appearance, design and safety standards. This provision shall not apply unless the proposal submitted is specifically identified by the Contractor as being presented for consideration as a value engineering proposal.

Not eligible for value engineering cost proposals are changes in the basic design of a pavement type, runway and taxiway lighting, visual aids, hydraulic capacity of drainage facilities, or changes in grade or alignment that reduce the geometric standards of the project.

As a minimum, the following information shall be submitted by the Contractor with each proposal:

- a. A description of both existing contract requirements for performing the work and the proposed changes, with a discussion of the comparative advantages and disadvantages of each.
- b. An itemization of the contract requirements that must be changed if the proposal is adopted.
- c. A detailed estimate of the cost of performing the work under the existing contract and under the proposed changes.
- d. A statement of the time by which a change order adopting the proposal must be issued.
- e. A statement of the effect adoption of the proposal will have on the time for completion of the contract.
- f. The contract items of work affected by the proposed changes, including any quantity variation attributable to them.

The Contractor may withdraw, in whole or in part, any value engineering cost proposal not accepted by the RPR, within the period specified in the proposal. The provisions of this subsection shall not be construed to require the RPR to consider any value engineering cost proposal that may be submitted.

The Contractor shall continue to perform the work in accordance with the requirements of the contract until a change order incorporating the value engineering cost proposal has been issued. If a change order has not been issued by the date upon which the Contractor's value engineering cost proposal specifies that a decision should be made, or such other date as the Contractor may subsequently have requested in writing, such value engineering cost proposal shall be deemed rejected.

The RPR shall be the sole judge of the acceptability of a value engineering cost proposal and of the estimated net savings from the adoption of all or any part of such proposal. In determining the estimated net savings, the RPR may disregard the contract bid prices if, in the RPR's judgment such prices do not represent a fair measure of the value of the work to be performed or deleted.

The Owner may require the Contractor to share in the Owner's costs of investigating a value engineering cost proposal submitted by the Contractor as a condition of considering such proposal. Where such a condition is imposed, the Contractor shall acknowledge acceptance of it in writing. Such acceptance shall constitute full authority for the Owner to deduct the cost of investigating a value engineering cost proposal from amounts payable to the Contractor under the contract.

If the Contractor's value engineering cost proposal is accepted in whole or in part, such acceptance will be by a contract change order that shall specifically state that it is executed pursuant to this paragraph. Such change order shall incorporate the changes in the plans and specifications which are necessary to permit the value engineering cost proposal or such part of it as has been accepted and shall include any conditions upon which the RPR's approval is based. The change order shall also set forth the estimated net savings attributable to the value engineering cost proposal. The net savings shall be determined as the difference in costs between the original contract costs for the involved work items and the costs occurring as a result of the proposed change. The change order shall also establish the net savings agreed upon and shall provide for adjustment in the contract price that will divide the net savings equally between the Contractor and the Owner.

The Contractor's 50% share of the net savings shall constitute full compensation to the Contractor for the value engineering cost proposal and the performance of the work.

Acceptance of the value engineering cost proposal and performance of the work shall not extend the time of completion of the contract unless specifically provided for in the contract change order.

END OF SECTION 50

Section 60 Control of Materials

60-01 Source of supply and quality requirements. The materials used in the work shall conform to the requirements of the contract, plans, and specifications. Unless otherwise specified, such materials that are manufactured or processed shall be new (as compared to used or reprocessed).

In order to expedite the inspection and testing of materials, the Contractor shall furnish documentation to the RPR as to the origin, composition, and manufacture of all materials to be used in the work. Documentation shall be furnished promptly after execution of the contract but, in all cases, prior to delivery of such materials.

At the RPR's option, materials may be approved at the source of supply before delivery. If it is found after trial that sources of supply for previously approved materials do not produce specified products, the Contractor shall furnish materials from other sources.

The Contractor shall furnish airport lighting equipment that meets the requirements of the specifications; and is listed in AC 150/5345-53, *Airport Lighting Equipment Certification Program and Addendum*, that is in effect on the date of advertisement.

60-02 Samples, tests, and cited specifications. All materials used in the work shall be inspected, tested, and approved by the RPR before incorporation in the work unless otherwise designated. Any work in which untested materials are used without approval or written permission of the RPR shall be performed at the Contractor's risk. Materials found to be unacceptable and unauthorized will not be paid for and, if directed by the RPR, shall be removed at the Contractor's expense.

Unless otherwise designated, quality assurance tests will be made by and at the expense of the Owner in accordance with the cited standard methods of ASTM, American Association of State Highway and Transportation Officials (AASHTO), federal specifications, Commercial Item Descriptions, and all other cited methods, which are current on the date of advertisement for bids.

The testing organizations performing on-site quality assurance field tests shall have copies of all referenced standards on the construction site for use by all technicians and other personnel. Unless otherwise designated, samples for quality assurance will be taken by a qualified representative of the RPR. All materials being used are subject to inspection, test, or rejection at any time prior to or during incorporation into the work. Copies of all tests will be furnished to the Contractor's representative at their request after review and approval of the RPR.

A copy of all Contractor QC test data shall be provided to the RPR daily, along with printed reports, in an approved format, on a weekly basis. After completion of the project, and prior to final payment, the Contractor shall submit a final report to the RPR showing all test data reports, plus an analysis of all results showing ranges, averages, and corrective action taken on all failing tests.

The Contractor shall employ a Quality Control (QC) testing organization to perform all Contractor required QC tests in accordance with Item C-100 Contractor Quality Control Program (CQCP).

60-03 Certification of compliance/analysis (COC/COA). The RPR may permit the use, prior to sampling and testing, of certain materials or assemblies when accompanied by manufacturer's COC stating that such materials or assemblies fully comply with the requirements of the contract. The certificate shall be signed by the manufacturer. Each lot of such materials or assemblies delivered to the work must be accompanied by a certificate of compliance in which the lot is clearly identified. The COA is the manufacturer's COC and includes all applicable test results.

Materials or assemblies used on the basis of certificates of compliance may be sampled and tested at any time and if found not to be in conformity with contract requirements will be subject to rejection whether in place or not.

The form and distribution of certificates of compliance shall be as approved by the RPR.

When a material or assembly is specified by “brand name or equal” and the Contractor elects to furnish the specified “or equal,” the Contractor shall be required to furnish the manufacturer’s certificate of compliance for each lot of such material or assembly delivered to the work. Such certificate of compliance shall clearly identify each lot delivered and shall certify as to:

- a. Conformance to the specified performance, testing, quality or dimensional requirements; and,
- b. Suitability of the material or assembly for the use intended in the contract work.

The RPR shall be the sole judge as to whether the proposed “or equal” is suitable for use in the work.

The RPR reserves the right to refuse permission for use of materials or assemblies on the basis of certificates of compliance.

60-04 Plant inspection. The RPR or their authorized representative may inspect, at its source, any specified material or assembly to be used in the work. Manufacturing plants may be inspected from time to time for the purpose of determining compliance with specified manufacturing methods or materials to be used in the work and to obtain samples required for acceptance of the material or assembly.

Should the RPR conduct plant inspections, the following conditions shall exist:

- a. The RPR shall have the cooperation and assistance of the Contractor and the producer with whom the Contractor has contracted for materials.
- b. The RPR shall have full entry at all reasonable times to such parts of the plant that concern the manufacture or production of the materials being furnished.
- c. If required by the RPR, the Contractor shall arrange for adequate office or working space that may be reasonably needed for conducting plant inspections. Place office or working space in a convenient location with respect to the plant.

It is understood and agreed that the Owner shall have the right to retest any material that has been tested and approved at the source of supply after it has been delivered to the site. The RPR shall have the right to reject only material which, when retested, does not meet the requirements of the contract, plans, or specifications.

60-05 Engineer/ Resident Project Representative (RPR) field office. An Engineer/RPR field office is not required.

60-06 Storage of materials. Materials shall be stored to assure the preservation of their quality and fitness for the work. Stored materials, even though approved before storage, may again be inspected prior to their use in the work. Stored materials shall be located to facilitate their prompt inspection. The Contractor shall coordinate the storage of all materials with the RPR. Materials to be stored on airport property shall not create an obstruction to air navigation nor shall they interfere with the free and unobstructed movement of aircraft. Unless otherwise shown on the plans and/or CSPP, the storage of materials and the location of the Contractor’s plant and parked equipment or vehicles shall be as directed by the RPR. Private property shall not be used for storage purposes without written permission of the Owner or lessee of such property. The Contractor shall make all arrangements and bear all expenses for the storage of materials on private property. Upon request, the Contractor shall furnish the RPR a copy of the property Owner’s permission.

All storage sites on private or airport property shall be restored to their original condition by the Contractor at their expense, except as otherwise agreed to (in writing) by the Owner or lessee of the property.

60-07 Unacceptable materials. Any material or assembly that does not conform to the requirements of the contract, plans, or specifications shall be considered unacceptable and shall be rejected. The Contractor shall remove any rejected material or assembly from the site of the work, unless otherwise instructed by the RPR.

Rejected material or assembly, the defects of which have been corrected by the Contractor, shall not be returned to the site of the work until such time as the RPR has approved its use in the work.

60-08 Owner furnished materials. The Contractor shall furnish all materials required to complete the work, except those specified, if any, to be furnished by the Owner. Owner-furnished materials shall be made available to the Contractor at the location specified.

All costs of handling, transportation from the specified location to the site of work, storage, and installing Owner-furnished materials shall be included in the unit price bid for the contract item in which such Owner-furnished material is used.

After any Owner-furnished material has been delivered to the location specified, the Contractor shall be responsible for any demurrage, damage, loss, or other deficiencies that may occur during the Contractor's handling, storage, or use of such Owner-furnished material. The Owner will deduct from any monies due or to become due the Contractor any cost incurred by the Owner in making good such loss due to the Contractor's handling, storage, or use of Owner-furnished materials.

END OF SECTION 60

Section 70 Legal Regulations and Responsibility to Public

70-01 Laws to be observed. The Contractor shall keep fully informed of all federal and state laws, all local laws, ordinances, and regulations and all orders and decrees of bodies or tribunals having any jurisdiction or authority, which in any manner affect those engaged or employed on the work, or which in any way affect the conduct of the work. The Contractor shall at all times observe and comply with all such laws, ordinances, regulations, orders, and decrees; and shall protect and indemnify the Owner and all their officers, agents, or servants against any claim or liability arising from or based on the violation of any such law, ordinance, regulation, order, or decree, whether by the Contractor or the Contractor's employees.

70-02 Permits, licenses, and taxes. The Contractor shall procure all permits and licenses, pay all charges, fees, and taxes, and give all notices necessary and incidental to the due and lawful execution of the work.

70-03 Patented devices, materials, and processes. If the Contractor is required or desires to use any design, device, material, or process covered by letters of patent or copyright, the Contractor shall provide for such use by suitable legal agreement with the Patentee or Owner. The Contractor and the surety shall indemnify and hold harmless the Owner, any third party, or political subdivision from any and all claims for infringement by reason of the use of any such patented design, device, material or process, or any trademark or copyright, and shall indemnify the Owner for any costs, expenses, and damages which it may be obliged to pay by reason of an infringement, at any time during the execution or after the completion of the work.

70-04 Restoration of surfaces disturbed by others. The Owner reserves the right to authorize the construction, reconstruction, or maintenance of any public or private utility service, FAA or National Oceanic and Atmospheric Administration (NOAA) facility, or a utility service of another government agency at any time during the progress of the work. To the extent that such construction, reconstruction, or maintenance has been coordinated with the Owner, such authorized work (by others) must be shown on the plans and is indicated as follows:

Except as listed above, the Contractor shall not permit any individual, firm, or corporation to excavate or otherwise disturb such utility services or facilities located within the limits of the work without the written permission of the RPR.

Should the Owner of public or private utility service, FAA, or NOAA facility, or a utility service of another government agency be authorized to construct, reconstruct, or maintain such utility service or facility during the progress of the work, the Contractor shall cooperate with such Owners by arranging and performing the work in this contract to facilitate such construction, reconstruction or maintenance by others whether or not such work by others is listed above. When ordered as extra work by the RPR, the Contractor shall make all necessary repairs to the work which are due to such authorized work by others, unless otherwise provided for in the contract, plans, or specifications. It is understood and agreed that the Contractor shall not be entitled to make any claim for damages due to such authorized work by others or for any delay to the work resulting from such authorized work.

70-05 Federal Participation. The United States Government has agreed to reimburse the Owner for some portion of the contract costs. The contract work is subject to the inspection and approval of duly authorized representatives of the FAA Administrator. No requirement of this contract shall be construed as making the United States a party to the contract nor will any such requirement interfere, in any way, with the rights of either party to the contract.

70-06 Sanitary, health, and safety provisions. The Contractor's worksite and facilities shall comply with applicable federal, state, and local requirements for health, safety and sanitary provisions.

70-07 Public convenience and safety. The Contractor shall control their operations and those of their subcontractors and all suppliers, to assure the least inconvenience to the traveling public. Under all circumstances, safety shall be the most important consideration.

The Contractor shall maintain the free and unobstructed movement of aircraft and vehicular traffic with respect to their own operations and those of their own subcontractors and all suppliers in accordance with Section 40, paragraph 40-05, *Maintenance of Traffic*, and shall limit such operations for the convenience and safety of the traveling public as specified in Section 80, paragraph 80-04, *Limitation of Operations*.

The Contractor shall remove or control debris and rubbish resulting from its work operations at frequent intervals, and upon the order of the RPR. If the RPR determines the existence of Contractor debris in the work site represents a hazard to airport operations and the Contractor is unable to respond in a prompt and reasonable manner, the RPR reserves the right to assign the task of debris removal to a third party and recover the resulting costs as a liquidated damage against the Contractor.

70-08 Construction Safety and Phasing Plan (CSPP). The Contractor shall complete the work in accordance with the approved Construction Safety and Phasing Plan (CSPP) developed in accordance with AC 150/5370-2, Operational Safety on Airports During Construction. The CSPP is included in the project plans.

70-09 Use of explosives. The use of explosives is not permitted on this project.

70-10 Protection and restoration of property and landscape. The Contractor shall be responsible for the preservation of all public and private property, and shall protect carefully from disturbance or damage all land monuments and property markers until the Engineer/RPR has witnessed or otherwise referenced their location and shall not move them until directed.

The Contractor shall be responsible for all damage or injury to property of any character, during the execution of the work, resulting from any act, omission, neglect, or misconduct in manner or method of executing the work, or at any time due to defective work or materials, and said responsibility shall not be released until the project has been completed and accepted.

When or where any direct or indirect damage or injury is done to public or private property by or on account of any act, omission, neglect, or misconduct in the execution of the work, or in consequence of the non-execution thereof by the Contractor, the Contractor shall restore, at their expense, such property to a condition similar or equal to that existing before such damage or injury was done, by repairing, or otherwise restoring as may be directed, or the Contractor shall make good such damage or injury in an acceptable manner.

70-11 Responsibility for damage claims. The Contractor shall indemnify and hold harmless the Engineer/RPR and the Owner and their officers, agents, and employees from all suits, actions, or claims, of any character, brought because of any injuries or damage received or sustained by any person, persons, or property on account of the operations of the Contractor; or on account of or in consequence of any neglect in safeguarding the work; or through use of unacceptable materials in constructing the work; or because of any act or omission, neglect, or misconduct of said Contractor; or because of any claims or amounts recovered from any infringements of patent, trademark, or copyright; or from any claims or amounts arising or recovered under the "Workmen's Compensation Act," or any other law, ordinance, order, or decree. Money due the Contractor under and by virtue of their own contract considered necessary by the Owner for such purpose may be retained for the use of the Owner or, in case no money is due, their own surety may be held until such suits, actions, or claims for injuries or damages shall have been settled and suitable evidence to that effect furnished to the Owner, except that money due the

Contractor will not be withheld when the Contractor produces satisfactory evidence that he or she is adequately protected by public liability and property damage insurance.

70-12 Third party beneficiary clause. It is specifically agreed between the parties executing the contract that it is not intended by any of the provisions of any part of the contract to create for the public or any member thereof, a third-party beneficiary or to authorize anyone not a party to the contract to maintain a suit for personal injuries or property damage pursuant to the terms or provisions of the contract.

70-13 Opening sections of the work to traffic. If it is necessary for the Contractor to complete portions of the contract work for the beneficial occupancy of the Owner prior to completion of the entire contract, such “phasing” of the work must be specified below and indicated on the approved Construction Safety and Phasing Plan (CSPP) and the project plans. When so specified, the Contractor shall complete such portions of the work on or before the date specified or as otherwise specified.

Upon completion of any portion of work listed above, such portion shall be accepted by the Owner in accordance with Section 50, paragraph 50-14, *Partial Acceptance*.

No portion of the work may be opened by the Contractor until directed by the Owner in writing. Should it become necessary to open a portion of the work to traffic on a temporary or intermittent basis, such openings shall be made when, in the opinion of the RPR, such portion of the work is in an acceptable condition to support the intended traffic. Temporary or intermittent openings are considered to be inherent in the work and shall not constitute either acceptance of the portion of the work so opened or a waiver of any provision of the contract. Any damage to the portion of the work so opened that is not attributable to traffic which is permitted by the Owner shall be repaired by the Contractor at their expense.

The Contractor shall make their own estimate of the inherent difficulties involved in completing the work under the conditions herein described and shall not claim any added compensation by reason of delay or increased cost due to opening a portion of the contract work.

The Contractor must conform to safety standards contained AC 150/5370-2 and the approved CSPP.

Contractor shall refer to the plans, specifications, and the approved CSPP to identify barricade requirements, temporary and/or permanent markings, airfield lighting, guidance signs and other safety requirements prior to opening up sections of work to traffic.

70-14 Contractor’s responsibility for work. Until the RPR’s final written acceptance of the entire completed work, excepting only those portions of the work accepted in accordance with Section 50, paragraph 50-14, *Partial Acceptance*, the Contractor shall have the charge and care thereof and shall take every precaution against injury or damage to any part due to the action of the elements or from any other cause, whether arising from the execution or from the non-execution of the work. The Contractor shall rebuild, repair, restore, and make good all injuries or damages to any portion of the work occasioned by any of the above causes before final acceptance and shall bear the expense thereof except damage to the work due to unforeseeable causes beyond the control of and without the fault or negligence of the Contractor, including but not restricted to acts of God such as earthquake, tidal wave, tornado, hurricane or other cataclysmic phenomenon of nature, or acts of the public enemy or of government authorities.

If the work is suspended for any cause whatever, the Contractor shall be responsible for the work and shall take such precautions necessary to prevent damage to the work. The Contractor shall provide for normal drainage and shall erect necessary temporary structures, signs, or other facilities at their own expense. During such period of suspension of work, the Contractor shall properly and continuously maintain in an acceptable growing condition all living material in newly established planting, seeding, and sodding furnished under the contract, and shall take adequate precautions to protect new tree growth and other important vegetative growth against injury.

70-15 Contractor’s responsibility for utility service and facilities of others. As provided in paragraph 70-04, *Restoration of Surfaces Disturbed by Others*, the Contractor shall cooperate with the owner of any

public or private utility service, FAA or NOAA, or a utility service of another government agency that may be authorized by the Owner to construct, reconstruct or maintain such utility services or facilities during the progress of the work. In addition, the Contractor shall control their operations to prevent the unscheduled interruption of such utility services and facilities.

To the extent that such public or private utility services, FAA, or NOAA facilities, or utility services of another governmental agency are known to exist within the limits of the contract work, the approximate locations have been indicated on the plans and/or in the contract documents.

It is understood and agreed that the Owner does not guarantee the accuracy or the completeness of the location information relating to existing utility services, facilities, or structures that may be shown on the plans or encountered in the work. Any inaccuracy or omission in such information shall not relieve the Contractor of the responsibility to protect such existing features from damage or unscheduled interruption of service.

It is further understood and agreed that the Contractor shall, upon execution of the contract, notify the Owners of all utility services or other facilities of their plan of operations. Such notification shall be in writing addressed to "The Person to Contact" as provided in this paragraph and paragraph 70-04, *Restoration of Surfaces Disturbed By Others*. A copy of each notification shall be given to the RPR.

In addition to the general written notification provided, it shall be the responsibility of the Contractor to keep such individual Owners advised of changes in their plan of operations that would affect such Owners.

Prior to beginning the work in the general vicinity of an existing utility service or facility, the Contractor shall again notify each such Owner of their plan of operation. If, in the Contractor's opinion, the Owner's assistance is needed to locate the utility service or facility or the presence of a representative of the Owner is desirable to observe the work, such advice should be included in the notification. Such notification shall be given by the most expeditious means to reach the utility owner's "Person to Contact" no later than two normal business days prior to the Contractor's commencement of operations in such general vicinity. The Contractor shall furnish a written summary of the notification to the RPR.

The Contractor's failure to give the two days' notice shall be cause for the Owner to suspend the Contractor's operations in the general vicinity of a utility service or facility.

Where the outside limits of an underground utility service have been located and staked on the ground, the Contractor shall be required to use hand excavation methods within 3 feet (1 m) of such outside limits at such points as may be required to ensure protection from damage due to the Contractor's operations.

Should the Contractor damage or interrupt the operation of a utility service or facility by accident or otherwise, the Contractor shall immediately notify the proper authority and the RPR and shall take all reasonable measures to prevent further damage or interruption of service. The Contractor, in such events, shall cooperate with the utility service or facility owner and the RPR continuously until such damage has been repaired and service restored to the satisfaction of the utility or facility owner.

The Contractor shall bear all costs of damage and restoration of service to any utility service or facility due to their operations whether due to negligence or accident. The Owner reserves the right to deduct such costs from any monies due or which may become due the Contractor, or their own surety.

70-15.1 FAA facilities and cable runs. The Contractor is hereby advised that the construction limits of the project include existing facilities and buried cable runs that are owned, operated and maintained by the FAA. The Contractor, during the execution of the project work, shall comply with the following:

a. The Contractor shall permit FAA maintenance personnel the right of access to the project work site for purposes of inspecting and maintaining all existing FAA owned facilities.

b. The Contractor shall provide notice to the FAA Air Traffic Organization (ATO)/Technical Operations/System Support Center (SSC) Point-of-Contact through the airport Owner a minimum of seven (7) calendar days prior to commencement of construction activities in order to permit sufficient time to locate and mark existing buried cables and to schedule any required facility outages.

c. If execution of the project work requires a facility outage, the Contractor shall contact the FAA Point-of-Contact a minimum of 72 hours prior to the time of the required outage.

d. Any damage to FAA cables, access roads, or FAA facilities during construction caused by the Contractor's equipment or personnel whether by negligence or accident will require the Contractor to repair or replace the damaged cables, access road, or FAA facilities to FAA requirements. The Contractor shall not bear the cost to repair damage to underground facilities or utilities improperly located by the FAA.

e. If the project work requires the cutting or splicing of FAA owned cables, the FAA Point-of-Contact shall be contacted a minimum of 72 hours prior to the time the cable work commences. The FAA reserves the right to have a FAA representative on site to observe the splicing of the cables as a condition of acceptance. All cable splices are to be accomplished in accordance with FAA specifications and require approval by the FAA Point-of-Contact as a condition of acceptance by the Owner. The Contractor is hereby advised that FAA restricts the location of where splices may be installed. If a cable splice is required in a location that is not permitted by FAA, the Contractor shall furnish and install a sufficient length of new cable that eliminates the need for any splice.

70-16 Furnishing rights-of-way. The Owner will be responsible for furnishing all rights-of-way upon which the work is to be constructed in advance of the Contractor's operations.

70-17 Personal liability of public officials. In carrying out any of the contract provisions or in exercising any power or authority granted by this contract, there shall be no liability upon the Engineer, RPR, their authorized representatives, or any officials of the Owner either personally or as an official of the Owner. It is understood that in such matters they act solely as agents and representatives of the Owner.

70-18 No waiver of legal rights. Upon completion of the work, the Owner will expeditiously make final inspection and notify the Contractor of final acceptance. Such final acceptance, however, shall not preclude or stop the Owner from correcting any measurement, estimate, or certificate made before or after completion of the work, nor shall the Owner be precluded or stopped from recovering from the Contractor or their surety, or both, such overpayment as may be sustained, or by failure on the part of the Contractor to fulfill their obligations under the contract. A waiver on the part of the Owner of any breach of any part of the contract shall not be held to be a waiver of any other or subsequent breach.

The Contractor, without prejudice to the terms of the contract, shall be liable to the Owner for latent defects, fraud, or such gross mistakes as may amount to fraud, or as regards the Owner's rights under any warranty or guaranty.

70-19 Environmental protection. The Contractor shall comply with all federal, state, and local laws and regulations controlling pollution of the environment. The Contractor shall take necessary precautions to prevent pollution of streams, lakes, ponds, and reservoirs with fuels, oils, asphalts, chemicals, or other harmful materials and to prevent pollution of the atmosphere from particulate and gaseous matter.

70-20 Archaeological and historical findings. Unless otherwise specified in this subsection, the Contractor is advised that the site of the work is not within any property, district, or site, and does not contain any building, structure, or object listed in the current National Register of Historic Places published by the United States Department of Interior.

Should the Contractor encounter, during their operations, any building, part of a building, structure, or object that is incongruous with its surroundings, the Contractor shall immediately cease operations in that

location and notify the RPR. The RPR will immediately investigate the Contractor's finding and the Owner will direct the Contractor to either resume operations or to suspend operations as directed.

Should the Owner order suspension of the Contractor's operations in order to protect an archaeological or historical finding, or order the Contractor to perform extra work, such shall be covered by an appropriate contract change order or supplemental agreement as provided in Section 40, paragraph 40-04, *Extra Work*, and Section 90, paragraph 90-05, *Payment for Extra Work*. If appropriate, the contract change order or supplemental agreement shall include an extension of contract time in accordance with Section 80, paragraph 80-07, *Determination and Extension of Contract Time*.

70-21 Insurance Requirements.

The Contractor shall indemnify, save harmless, and waive their right to subrogate against the Engineer and the Owner, and their respective officers and employees, (individually and collectively, the "Indemnified Parties"), from and against any and all suits, judgments, actions, claims and liabilities, of any character, brought because of or arising out of any personal or bodily injury or damage received or sustained by any person(s) or property on account of the operations of the Contractor; or on account of, or in consequence of, any neglect in safeguarding the work; or through use of unacceptable materials in constructing the work; or because of any act or omission, neglect or misconduct of said Contractor; or because of any claims or amounts recovered from any infringement(s) of patent, trademark or copyright; or from any claims or amounts arising or recovered under the "Workmen's Compensation Act", or any other law, ordinance, order or decree. Money due to the Contractor under and by virtue of its contract as may be considered necessary by the Owner for such purpose may be retained for the use of the Owner, or, in case no money is due, his or her surety may be held until such suits, judgments, actions, claims or liabilities for injuries or damages as aforesaid, shall have been settled and suitable evidence to that effect furnished to the Owner, except that money due to the Contractor will not be withheld when the Contractor produces satisfactory evidence that it is adequately protected by public liability and/or property damage insurance, as applicable, in accordance with the coverages outlined in the insurance section below. Contractor's insurance coverage shall be primary and the insurance of the Engineer and the Owner, and their respective officers and employees, (individually and collectively, the "Indemnified Parties") shall not contribute in any way for incidents brought because of or arising out of any personal or bodily injury or damage received or sustained by any person(s) or property on account of the operations of the Contractor; or on account of, or in consequence of, any neglect in safeguarding the work; or through use of unacceptable materials in constructing the work; or because of any act or omission, neglect or misconduct of said Contractor; or because of any claims or amounts recovered from any infringement(s) of patent, trademark or copyright; or from any claims or amounts arising or recovered under the "Workmen's Compensation Act", or any other law, ordinance, order or decree.

INSURANCE (LIABILITY). Before commencing the work hereunder, Contractor shall pay for (as part of the cost of the work), and shall keep in full force and effect during the entire term hereof, insurance issued by a company satisfactory to Owner, and qualified to do business in the state the project is located, as follows:

1. Worker's Compensation Insurance. CONTRACTOR shall file with Owner a certification that CONTRACTOR carries Worker's Compensation Insurance in the sum as required by the law of the state the project is in.
2. Bodily Injury and Property Damage. CONTRACTOR shall file with Owner copies of completed Certificates of Insurance, as evidence that CONTRACTOR carries adequate insurance, satisfactory to Owner, to provide protection against all claims for damages to public or private property, and for bodily injury and/or death to persons, arising out of and during the performance of the Contract, and to protect Owner's premises on or near the location on which construction operations are to be performed.
 - a. Bodily Injury and Property Damage Other Than Automobile.
Unless otherwise specifically required by provisions in the proposal, the minimum limits of property damage and bodily injury liability covering each contract shall be:

\$3,000,000 per occurrence
 - b. Comprehensive Automobile Liability Insurance.

Includes coverage for any vehicle owned by the entity or used for the benefit of the operation on airport (including, but not limited to, all owned, non-owned, hired, licensed or unlicensed, vehicles or leased vehicles, and providing automatic coverage for newly acquired vehicle, covering Bodily Injury (including death) and Property Damage Liability with a combined single limit of not less than the limits set forth below:

\$3,000,000 per occurrence

c. Umbrella or Excess Liability.

In lieu of the total limits of liability being provided under the primary Commercial General Liability and Automobile Liability insurance, the entities or outside parties may provide the liability limit specified by means of a combination of primary and Umbrella/Excess Liability insurance. The Umbrella/Excess Liability coverage must be as broad as or broader than the primary insurance policies.

If Umbrella policies are utilized to meet any limits as prescribed above, all applicable Umbrella policies are required to be endorsed to meet the requirements of coverage as outlined for Worker's Compensation, Automobile Liability, and Commercial General Liability.

d. Owner's Protective Liability.

Where required as an incident to compliance with Federal laws and regulations, bodily injury and property damage protection shall be extended to Owner and Engineer and its agents.

e. Builder's Risk Insurance.

If the project involves a building or structure, the Contractor shall maintain Builder's Risk Insurance at a financial level to cover the cost of the completed project. If the amount of the original contract is increased by change order, the amount of Builder's Risk Insurance coverage must include the increase in the project cost

3. Reports. At the request of Owner or its agent, CONTRACTOR or its insurance carrier shall report claims received, inspections made, and disposition of claims.

The Owner, the Engineer, and the Construction Managers, and their respective officers, directors, employees, representatives and agents shall be named as an "additional insured", using Contractors Endorsement (CG2010 Ed. 11-85 or its equivalent) or a comparable Blanket Additional Insured Endorsement "which includes both premises liability coverage as well as products and completed operations coverage". Contractor shall also provide the proper endorsement(s) and policy corresponding to Contractor naming the Owner, the Engineer, and the Construction Managers, and their respective officers, directors, employee, representatives and agents as an "additional insured."

Coverage provided to the Owner, the Engineer, and the Construction Managers, as additional insureds under the contractors' liability policy, shall apply on a primary and non-contributory basis.

Before commencing any work on the project, Contractor shall furnish to the Owner, the Engineers, and the Construction Managers, and any other persons designated by the Owner, certificates issued by the company or companies issuing such insurance, evidencing that such insurance is in full force and effect and expressly providing that no such insurance may be cancelled or changed without at least thirty (30) days' prior written notice thereof.

In addition, if requested by the Owner, the Engineer, or the Construction Managers, duplicate policies and applicable policy endorsements shall be furnished. At the request of the Owner, the Engineer, or the Construction Managers, the Contractor also shall promptly cause any and all government agencies and political subdivisions having an interest in the project, or any part thereof, to be named as additional insured parties under all of the aforesaid liability and casualty insurance policies, and shall furnish insurance certificates to them. The Contractor shall not commence or permit any subcontractor to commence any work until each has fully complied with the insurance requirements set forth herein.

END OF SECTION 70

Page Intentionally Blank

Section 80 Execution and Progress

80-01 Subletting of contract. The Owner will not recognize any subcontractor on the work. The Contractor shall at all times when work is in progress be represented either in person, by a qualified superintendent, or by other designated, qualified representative who is duly authorized to receive and execute orders of the Resident Project Representative (RPR).

The Contractor shall perform, with his organization, an amount of work equal to at least [___] percent of the total contract cost.

Should the Contractor elect to assign their contract, said assignment shall be concurred in by the surety, shall be presented for the consideration and approval of the Owner, and shall be consummated only on the written approval of the Owner.

The Contractor shall provide copies of all subcontracts to the RPR 14 days prior to being utilized on the project. As a minimum, the information shall include the following:

- Subcontractor's legal company name.
- Subcontractor's legal company address, including County name.
- Principal contact person's name, telephone and fax number.
- Complete narrative description, and dollar value of the work to be performed by the subcontractor.
- Copies of required insurance certificates in accordance with the specifications.
- Minority/ non-minority status.

80-02 Notice to proceed (NTP). The Owners notice to proceed will state the date on which contract time commences. The Contractor is expected to commence project operations within 3 days of the NTP date. The Contractor shall notify the RPR at least 24 hours in advance of the time contract operations begins. The Contractor shall not commence any actual operations prior to the date on which the notice to proceed is issued by the Owner.

80-03 Execution and progress. Unless otherwise specified, the Contractor shall submit their coordinated construction schedule showing all work activities for the RPR's review and acceptance at least 10 days prior to the start of work. The Contractor's progress schedule, once accepted by the RPR, will represent the Contractor's baseline plan to accomplish the project in accordance with the terms and conditions of the Contract. The RPR will compare actual Contractor progress against the baseline schedule to determine that status of the Contractor's performance. The Contractor shall provide sufficient materials, equipment, and labor to guarantee the completion of the project in accordance with the plans and specifications within the time set forth in the proposal.

If the Contractor falls significantly behind the submitted schedule, the Contractor shall, upon the RPR's request, submit a revised schedule for completion of the work within the contract time and modify their operations to provide such additional materials, equipment, and labor necessary to meet the revised schedule. Should the execution of the work be discontinued for any reason, the Contractor shall notify the RPR at least 24 hours in advance of resuming operations.

The Contractor shall not commence any actual construction prior to the date on which the NTP is issued by the Owner.

The project schedule shall be prepared as a network diagram in Critical Path Method (CPM), Program Evaluation and Review Technique (PERT), or other format, or as otherwise specified. It shall include information on the sequence of work activities, milestone dates, and activity duration. The schedule shall show all work items identified in the project proposal for each work area and shall include the project start date and end date.

The Contractor shall maintain the work schedule and provide an update and analysis of the progress schedule on a [twice] monthly basis, or as otherwise specified in the contract. Submission of the work schedule shall not relieve the Contractor of overall responsibility for scheduling, sequencing, and coordinating all work to comply with the requirements of the contract.

80-04 Limitation of operations. The Contractor shall control their operations and the operations of their subcontractors and all suppliers to provide for the free and unobstructed movement of aircraft in the air operations areas (AOA) of the airport.

When the work requires the Contractor to conduct their operations within an AOA of the airport, the work shall be coordinated with airport operations (through the RPR) at least [48 hours] prior to commencement of such work. The Contractor shall not close an AOA until so authorized by the RPR and until the necessary temporary marking, signage and associated lighting is in place as provided in Section 70, paragraph 70-08, *Construction Safety and Phasing Plan (CSPP)*.

When the contract work requires the Contractor to work within an AOA of the airport on an intermittent basis (intermittent opening and closing of the AOA), the Contractor shall maintain constant communications as specified; immediately obey all instructions to vacate the AOA; and immediately obey all instructions to resume work in such AOA. Failure to maintain the specified communications or to obey instructions shall be cause for suspension of the Contractor's operations in the AOA until satisfactory conditions are provided. The areas of the AOA identified in the Construction Safety Phasing Plan (CSPP), cannot be closed to operating aircraft to permit the Contractor's operations on a continuous basis and will therefore be closed to aircraft operations intermittently.

The Contractor shall be required to conform to safety standards contained in AC 150/5370-2, Operational Safety on Airports During Construction and the approved CSPP.

80-04.1 Operational safety on airport during construction. All Contractors' operations shall be conducted in accordance with the approved project Construction Safety and Phasing Plan (CSPP) and the Safety Plan Compliance Document (SPCD) and the provisions set forth within the current version of AC 150/5370-2, Operational Safety on Airports During Construction. The CSPP included within the contract documents conveys minimum requirements for operational safety on the airport during construction activities. The Contractor shall prepare and submit a SPCD that details how it proposes to comply with the requirements presented within the CSPP.

The Contractor shall implement all necessary safety plan measures prior to commencement of any work activity. The Contractor shall conduct routine checks to assure compliance with the safety plan measures.

The Contractor is responsible to the Owner for the conduct of all subcontractors it employs on the project. The Contractor shall assure that all subcontractors are made aware of the requirements of the CSPP and SPCD and that they implement and maintain all necessary measures.

No deviation or modifications may be made to the approved CSPP and SPCD unless approved in writing by the Owner. The necessary coordination actions to review Contractor proposed modifications to an approved CSPP or approved SPCD can require a significant amount of time.

80-05 Character of workers, methods, and equipment. The Contractor shall, at all times, employ sufficient labor and equipment for prosecuting the work to full completion in the manner and time required by the contract, plans, and specifications.

All workers shall have sufficient skill and experience to perform properly the work assigned to them. Workers engaged in special work or skilled work shall have sufficient experience in such work and in the operation of the equipment required to perform the work satisfactorily.

Any person employed by the Contractor or by any subcontractor who violates any operational regulations or operational safety requirements and, in the opinion of the RPR, does not perform his work in a proper and skillful manner or is intemperate or disorderly shall, at the written request of the RPR, be removed immediately by the Contractor or subcontractor employing such person, and shall not be employed again in any portion of the work without approval of the RPR.

Should the Contractor fail to remove such person or persons, or fail to furnish suitable and sufficient personnel for the proper execution of the work, the RPR may suspend the work by written notice until compliance with such orders.

All equipment that is proposed to be used on the work shall be of sufficient size and in such mechanical condition as to meet requirements of the work and to produce a satisfactory quality of work. Equipment used on any portion of the work shall not cause injury to previously completed work, adjacent property, or existing airport facilities due to its use.

When the methods and equipment to be used by the Contractor in accomplishing the work are not prescribed in the contract, the Contractor is free to use any methods or equipment that will accomplish the work in conformity with the requirements of the contract, plans, and specifications.

When the contract specifies the use of certain methods and equipment, such methods and equipment shall be used unless otherwise authorized by the RPR. If the Contractor desires to use a method or type of equipment other than specified in the contract, the Contractor may request authority from the RPR to do so. The request shall be in writing and shall include a full description of the methods and equipment proposed and of the reasons for desiring to make the change. If approval is given, it will be on the condition that the Contractor will be fully responsible for producing work in conformity with contract requirements. If, after trial use of the substituted methods or equipment, the RPR determines that the work produced does not meet contract requirements, the Contractor shall discontinue the use of the substitute method or equipment and shall complete the remaining work with the specified methods and equipment. The Contractor shall remove any deficient work and replace it with work of specified quality, or take such other corrective action as the RPR may direct. No change will be made in basis of payment for the contract items involved nor in contract time as a result of authorizing a change in methods or equipment under this paragraph.

80-06 Temporary suspension of the work. The Owner shall have the authority to suspend the work wholly, or in part, for such period or periods the Owner may deem necessary, due to unsuitable weather, or other conditions considered unfavorable for the execution of the work, or for such time necessary due to the failure on the part of the Contractor to carry out orders given or perform any or all provisions of the contract.

In the event that the Contractor is ordered by the Owner, in writing, to suspend work for some unforeseen cause not otherwise provided for in the contract and over which the Contractor has no control, the Contractor may be reimbursed for actual money expended on the work during the period of shutdown. No allowance will be made for anticipated profits. The period of shutdown shall be computed from the effective date of the written order to suspend work to the effective date of the written order to resume the work. Claims for such compensation shall be filed with the RPR within the time period stated in the RPR's order to resume work. The Contractor shall submit with their own claim information substantiating the amount shown on the claim. The RPR will forward the Contractor's claim to the Owner for

consideration in accordance with local laws or ordinances. No provision of this article shall be construed as entitling the Contractor to compensation for delays due to inclement weather or for any other delay provided for in the contract, plans, or specifications.

If it becomes necessary to suspend work for an indefinite period, the Contractor shall store all materials in such manner that they will not become an obstruction nor become damaged in any way. The Contractor shall take every precaution to prevent damage or deterioration of the work performed and provide for normal drainage of the work. The Contractor shall erect temporary structures where necessary to provide for traffic on, to, or from the airport.

80-07 Determination and extension of contract time. The number of calendar days, the number of working days, or the completion date shall be stated in the proposal and contract and shall be known as the Contract Time.

If the contract time requires extension for reasons beyond the Contractor's control, it shall be adjusted as follows:

80-07.1 Contract time based on working days. Contract time based on working days shall be calculated weekly by the Resident Project Representative (RPR). The RPR will furnish the Contractor a copy of their weekly statement of the number of working days charged against the contract time during the week and the number of working days currently specified for completion of the contract (the original contract time plus the number of working days, if any, that have been included in approved Change Orders or Supplemental Agreements covering Extra Work).

The weekly statement of contract time charged is based on the following considerations:

(1) Time will be charged for days on which the Contractor could proceed with scheduled work under construction at the time for at least six (6) hours with the normal work force employed on such items. When normal work force is a double-shift, use 12 hours; and when the normal work force is on a triple-shift, use 18 hours. Conditions beyond the Contractor's control such as strikes, lockouts, unusual delays in transportation, temporary suspension of the scheduled work items under construction or temporary suspension of the entire work which have been ordered by the Owner for reasons not the fault of the Contractor, shall not be charged against the contract time.

(2) The RPR will not make charges against the contract time prior to the effective date of the notice to proceed.

(3) The RPR will begin charges against the contract time on the first working day after the effective date of the notice to proceed.

(4) The RPR will not make charges against the contract time after the date of final acceptance as defined in Section 50, paragraph 50-14, *Final Acceptance*.

(5) The Contractor will be allowed one (1) week in which to file a written protest setting forth their own objections to the RPR's weekly statement. If no objection is filed within such specified time, the weekly statement shall be considered as acceptable to the Contractor.

The contract time (stated in the proposal) is based on the originally estimated quantities as described in the Section 20, paragraph 20-05, *Interpretation of Estimated Proposal Quantities*. Should the satisfactory completion of the contract require performance of work in greater quantities than those estimated in the proposal, the contract time shall be increased in the same proportion as the cost of the actually completed quantities bears to the cost of the originally estimated quantities in the proposal. Such increase in contract time shall not consider either the cost of work or the extension of contract time that has been covered by change order or supplemental agreement and shall be made at the time of final payment.

Contract time based on calendar days. Contract Time based on calendar days shall consist of the number of calendar days stated in the contract counting from the effective date of the Notice to Proceed

and including all Saturdays, Sundays, holidays, and non-work days. All calendar days elapsing between the effective dates of the Owner's orders to suspend and resume all work, due to causes not the fault of the Contractor, shall be excluded.

At the time of final payment, the contract time shall be increased in the same proportion as the cost of the actually completed quantities bears to the cost of the originally estimated quantities in the proposal. Such increase in the contract time shall not consider either cost of work or the extension of contract time that has been covered by a change order or supplemental agreement. Charges against the contract time will cease as of the date of final acceptance.

Contract time based on specific completion date. When the contract time is a specified completion date, it shall be the date on which all contract work shall be substantially complete.

If the Contractor finds it impossible for reasons beyond their own control to complete the work within the contract time as specified, or as extended in accordance with the provisions of this paragraph, the Contractor may, at any time prior to the expiration of the contract time as extended, make a written request to the Owner for an extension of time setting forth the reasons which the Contractor believes will justify the granting of their own request. Requests for extension of time, caused by inclement weather, shall be supported with National Weather Bureau data showing the actual amount of inclement weather exceeded what could normally be expected during the contract period. The Contractor's plea that insufficient time was specified is not a valid reason for extension of time. If the supporting documentation justify the work was delayed because of conditions beyond the control and without the fault of the Contractor, the Owner may extend the time for completion by a change order that adjusts the contract time or completion date. The extended time for completion shall then be in full force and effect, the same as though it were the original time for completion.

80-08 Failure to complete on time. For each calendar day or working day, as specified in the contract, that any work remains uncompleted after the contract time (including all extensions and adjustments as provided in paragraph 80-07, *Determination and Extension of Contract Time*) the sum specified in the contract and proposal as liquidated damages (LD) will be deducted from any money due or to become due the Contractor or their own surety. Such deducted sums shall not be deducted as a penalty but shall be considered as liquidation of a reasonable portion of damages including but not limited to additional engineering services that will be incurred by the Owner should the Contractor fail to complete the work in the time provided in their contract.

The maximum construction time allowed for Schedules **SEE SPECIAL PROVISIONS** will be the sum of the time allowed for individual schedules but not more than **SEE SPECIAL PROVISIONS** days. Permitting the Contractor to continue and finish the work or any part of it after the time fixed for its completion, or after the date to which the time for completion may have been extended, will in no way operate as a waiver on the part of the Owner of any of its rights under the contract.

80-09 Default and termination of contract. The Contractor shall be considered in default of their contract and such default will be considered as cause for the Owner to terminate the contract for any of the following reasons, if the Contractor:

- a. Fails to begin the work under the contract within the time specified in the Notice to Proceed, or
- b. Fails to perform the work or fails to provide sufficient workers, equipment and/or materials to assure completion of work in accordance with the terms of the contract, or
- c. Performs the work unsuitably or neglects or refuses to remove materials or to perform anew such work as may be rejected as unacceptable and unsuitable, or
- d. Discontinues the execution of the work, or
- e. Fails to resume work which has been discontinued within a reasonable time after notice to do so, or

- f. Becomes insolvent or is declared bankrupt, or commits any act of bankruptcy or insolvency, or
- g. Allows any final judgment to stand against the Contractor unsatisfied for a period of 10 days, or
- h. Makes an assignment for the benefit of creditors, or
- i. For any other cause whatsoever, fails to carry on the work in an acceptable manner.

Should the Owner consider the Contractor in default of the contract for any reason above, the Owner shall immediately give written notice to the Contractor and the Contractor's surety as to the reasons for considering the Contractor in default and the Owner's intentions to terminate the contract.

If the Contractor or surety, within a period of 10 days after such notice, does not proceed in accordance therewith, then the Owner will, upon written notification from the RPR of the facts of such delay, neglect, or default and the Contractor's failure to comply with such notice, have full power and authority without violating the contract, to take the execution of the work out of the hands of the Contractor. The Owner may appropriate or use any or all materials and equipment that have been mobilized for use in the work and are acceptable and may enter into an agreement for the completion of said contract according to the terms and provisions thereof, or use such other methods as in the opinion of the RPR will be required for the completion of said contract in an acceptable manner.

All costs and charges incurred by the Owner, together with the cost of completing the work under contract, will be deducted from any monies due or which may become due the Contractor. If such expense exceeds the sum which would have been payable under the contract, then the Contractor and the surety shall be liable and shall pay to the Owner the amount of such excess.

80-10 Termination for national emergencies. The Owner shall terminate the contract or portion thereof by written notice when the Contractor is prevented from proceeding with the construction contract as a direct result of an Executive Order of the President with respect to the execution of war or in the interest of national defense.

When the contract, or any portion thereof, is terminated before completion of all items of work in the contract, payment will be made for the actual number of units or items of work completed at the contract price or as mutually agreed for items of work partially completed or not started. No claims or loss of anticipated profits shall be considered.

Reimbursement for organization of the work, and other overhead expenses, (when not otherwise included in the contract) and moving equipment and materials to and from the job will be considered, the intent being that an equitable settlement will be made with the Contractor.

Acceptable materials, obtained or ordered by the Contractor for the work and that are not incorporated in the work shall, at the option of the Contractor, be purchased from the Contractor at actual cost as shown by receipted bills and actual cost records at such points of delivery as may be designated by the RPR.

Termination of the contract or a portion thereof shall neither relieve the Contractor of their responsibilities for the completed work nor shall it relieve their surety of its obligation for and concerning any just claim arising out of the work performed.

80-11 Work area, storage area and sequence of operations. The Contractor shall obtain approval from the RPR prior to beginning any work in all areas of the airport. No operating runway, taxiway, or air operations area (AOA) shall be crossed, entered, or obstructed while it is operational. The Contractor shall plan and coordinate work in accordance with the approved CSPP and SPCD.

END OF SECTION 80

Section 90 Measurement and Payment

90-01 Measurement of quantities. All work completed under the contract will be measured by the RPR, or their authorized representatives, using United States Customary Units of Measurement.

The method of measurement and computations to be used in determination of quantities of material furnished and of work performed under the contract will be those methods generally recognized as conforming to good engineering practice.

Unless otherwise specified, longitudinal measurements for area computations will be made horizontally, and no deductions will be made for individual fixtures (or leave-outs) having an area of 9 square feet (0.8 square meters) or less. Unless otherwise specified, transverse measurements for area computations will be the neat dimensions shown on the plans or ordered in writing by the RPR.

Unless otherwise specified, all contract items which are measured by the linear foot such as electrical ducts, conduits, pipe culverts, underdrains, and similar items shall be measured parallel to the base or foundation upon which such items are placed.

The term “lump sum” when used as an item of payment will mean complete payment for the work described in the contract. When a complete structure or structural unit (in effect, “lump sum” work) is specified as the unit of measurement, the unit will be construed to include all necessary fittings and accessories.

When requested by the Contractor and approved by the RPR in writing, material specified to be measured by the cubic yard (cubic meter) may be weighed, and such weights will be converted to cubic yards (cubic meters) for payment purposes. Factors for conversion from weight measurement to volume measurement will be determined by the RPR and shall be agreed to by the Contractor before such method of measurement of pay quantities is used.

Measurement and Payment Terms

Term	Description
Excavation and Embankment Volume	In computing volumes of excavation, the average end area method will be used unless otherwise specified.
Measurement and Proportion by Weight	The term “ton” will mean the short ton consisting of 2,000 pounds (907 kg) avoirdupois. All materials that are measured or proportioned by weights shall be weighed on accurate, independently certified scales by competent, qualified personnel at locations designated by the RPR. If material is shipped by rail, the car weight may be accepted provided that only the actual weight of material is paid for. However, car weights will not be acceptable for material to be passed through mixing plants. Trucks used to haul material being paid for by weight shall be weighed empty daily at such times as the RPR directs, and each truck shall bear a plainly legible identification mark.
Measurement by Volume	Materials to be measured by volume in the hauling vehicle shall be hauled in approved vehicles and measured therein at the point of delivery. Vehicles for this purpose may be of any size or type acceptable for the materials hauled, provided that the body is of such shape that the actual contents may be readily and accurately determined. All vehicles

Term	Description
	shall be loaded to at least their water level capacity, and all loads shall be leveled when the vehicles arrive at the point of delivery.
Asphalt Material	Asphalt materials will be measured by the gallon (liter) or ton (kg). When measured by volume, such volumes will be measured at 60°F (16°C) or will be corrected to the volume at 60°F (16°C) using ASTM D1250 for asphalts. Net certified scale weights or weights based on certified volumes in the case of rail shipments will be used as a basis of measurement, subject to correction when asphalt material has been lost from the car or the distributor, wasted, or otherwise not incorporated in the work. When asphalt materials are shipped by truck or transport, net certified weights by volume, subject to correction for loss or foaming, will be used for computing quantities.
Cement	Cement will be measured by the ton (kg) or hundredweight (km).
Structure	Structures will be measured according to neat lines shown on the plans or as altered to fit field conditions.
Timber	Timber will be measured by the thousand feet board measure (MFBM) actually incorporated in the structure. Measurement will be based on nominal widths and thicknesses and the extreme length of each piece.
Plates and Sheets	The thickness of plates and galvanized sheet used in the manufacture of corrugated metal pipe, metal plate pipe culverts and arches, and metal cribbing will be specified and measured in decimal fraction of inch.
Miscellaneous Items	When standard manufactured items are specified such as fence, wire, plates, rolled shapes, pipe conduit, etc., and these items are identified by gauge, unit weight, section dimensions, etc., such identification will be considered to be nominal weights or dimensions. Unless more stringently controlled by tolerances in cited specifications, manufacturing tolerances established by the industries involved will be accepted.
Scales	<p>Scales must be tested for accuracy and serviced before use. Scales for weighing materials which are required to be proportioned or measured and paid for by weight shall be furnished, erected, and maintained by the Contractor, or be certified permanently installed commercial scales. Platform scales shall be installed and maintained with the platform level and rigid bulkheads at each end.</p> <p>Scales shall be accurate within 0.5% of the correct weight throughout the range of use. The Contractor shall have the scales checked under the observation of the RPR before beginning work and at such other times as requested. The intervals shall be uniform in spacing throughout the graduated or marked length of the beam or dial and shall not exceed 0.1% of the nominal rated capacity of the scale, but not less than one pound (454 grams). The use of spring balances will not be permitted.</p> <p>In the event inspection reveals the scales have been “overweighing” (indicating more than correct weight) they will be immediately adjusted. All materials received subsequent to the last previous correct weighing-accuracy test will be reduced by the percentage of error in excess of 0.5%.</p> <p>In the event inspection reveals the scales have been under-weighing (indicating less than correct weight), they shall be immediately adjusted. No additional payment to the Contractor will be allowed for materials previously weighed and recorded.</p> <p>Beams, dials, platforms, and other scale equipment shall be so arranged that the operator and the RPR can safely and conveniently view them.</p>

Term	Description
	<p>Scale installations shall have available ten standard 50-pound (2.3 km) weights for testing the weighing equipment or suitable weights and devices for other approved equipment.</p> <p>All costs in connection with furnishing, installing, certifying, testing, and maintaining scales; for furnishing check weights and scale house; and for all other items specified in this subsection, for the weighing of materials for proportioning or payment, shall be included in the unit contract prices for the various items of the project.</p>
Rental Equipment	<p>Rental of equipment will be measured by time in hours of actual working time and necessary traveling time of the equipment within the limits of the work. Special equipment ordered in connection with extra work will be measured as agreed in the change order or supplemental agreement authorizing such work as provided in paragraph 90-05 <i>Payment for Extra Work</i>.</p>
Pay Quantities	<p>When the estimated quantities for a specific portion of the work are designated as the pay quantities in the contract, they shall be the final quantities for which payment for such specific portion of the work will be made, unless the dimensions of said portions of the work shown on the plans are revised by the RPR. If revised dimensions result in an increase or decrease in the quantities of such work, the final quantities for payment will be revised in the amount represented by the authorized changes in the dimensions.</p>

90-02 Scope of payment. The Contractor shall receive and accept compensation provided for in the contract as full payment for furnishing all materials, for performing all work under the contract in a complete and acceptable manner, and for all risk, loss, damage, or expense of whatever character arising out of the nature of the work or the execution thereof, subject to the provisions of Section 70, paragraph 70-18, *No Waiver of Legal Rights*.

When the “basis of payment” subsection of a technical specification requires that the contract price (price bid) include compensation for certain work or material essential to the item, this same work or material will not also be measured for payment under any other contract item which may appear elsewhere in the contract, plans, or specifications.

90-03 Compensation for altered quantities. When the accepted quantities of work vary from the quantities in the proposal, the Contractor shall accept as payment in full, so far as contract items are concerned, payment at the original contract price for the accepted quantities of work actually completed and accepted. No allowance, except as provided for in Section 40, paragraph 40-02, *Alteration of Work and Quantities*, will be made for any increased expense, loss of expected reimbursement, or loss of anticipated profits suffered or claimed by the Contractor which results directly from such alterations or indirectly from their own unbalanced allocation of overhead and profit among the contract items, or from any other cause.

90-04 Payment for omitted items. As specified in Section 40, paragraph 40-03, *Omitted Items*, the RPR shall have the right to omit from the work (order nonperformance) any contract item, except major contract items, in the best interest of the Owner.

Should the RPR omit or order nonperformance of a contract item or portion of such item from the work, the Contractor shall accept payment in full at the contract prices for any work actually completed and acceptable prior to the RPR’s order to omit or non-perform such contract item.

Acceptable materials ordered by the Contractor or delivered on the work prior to the date of the RPR’s order will be paid for at the actual cost to the Contractor and shall thereupon become the property of the Owner.

In addition to the reimbursement hereinbefore provided, the Contractor shall be reimbursed for all actual costs incurred for the purpose of performing the omitted contract item prior to the date of the RPR's order. Such additional costs incurred by the Contractor must be directly related to the deleted contract item and shall be supported by certified statements by the Contractor as to the nature the amount of such costs.

90-05 Payment for extra work. Extra work, performed in accordance with Section 40, paragraph 40-04, *Extra Work*, will be paid for at the contract prices or agreed prices specified in the change order or supplemental agreement authorizing the extra work.

90-06 Partial payments. Partial payments will be made to the Contractor at least once each month as the work progresses. Said payments will be based upon estimates, prepared by the RPR, of the value of the work performed and materials complete and in place, in accordance with the contract, plans, and specifications. Such partial payments may also include the delivered actual cost of those materials stockpiled and stored in accordance with paragraph 90-07, *Payment for Materials on Hand*. No partial payment will be made when the amount due to the Contractor since the last estimate amounts to less than five hundred dollars.

a. From the total of the amount determined to be payable on a partial payment, 5 percent of such total amount will be deducted and retained by the Owner for protection of the Owner's interests. Unless otherwise instructed by the Owner, the amount retained by the Owner will be in effect until the final payment is made except as follows:

(1) Contractor may request release of retainage on work that has been partially accepted by the Owner in accordance with Section 50-14. Contractor must provide a certified invoice to the RPR that supports the value of retainage held by the Owner for partially accepted work.

(2) In lieu of retainage, the Contractor may exercise at its option the establishment of an escrow account per paragraph 90-08.

b. The Contractor is required to pay all subcontractors for satisfactory performance of their contracts no later than 30 days after the Contractor has received a partial payment. Contractor must provide the Owner evidence of prompt and full payment of retainage held by the prime Contractor to the subcontractor within 30 days after the subcontractor's work is satisfactorily completed. A subcontractor's work is satisfactorily completed when all the tasks called for in the subcontract have been accomplished and documented as required by the Owner. When the Owner has made an incremental acceptance of a portion of a prime contract, the work of a subcontractor covered by that acceptance is deemed to be satisfactorily completed.

c. When at least 95% of the work has been completed to the satisfaction of the RPR, the RPR shall, at the Owner's discretion and with the consent of the surety, prepare estimates of both the contract value and the cost of the remaining work to be done. The Owner may retain an amount not less than twice the contract value or estimated cost, whichever is greater, of the work remaining to be done. The remainder, less all previous payments and deductions, will then be certified for payment to the Contractor.

It is understood and agreed that the Contractor shall not be entitled to demand or receive partial payment based on quantities of work in excess of those provided in the proposal or covered by approved change orders or supplemental agreements, except when such excess quantities have been determined by the RPR to be a part of the final quantity for the item of work in question.

No partial payment shall bind the Owner to the acceptance of any materials or work in place as to quality or quantity. All partial payments are subject to correction at the time of final payment as provided in paragraph 90-09, *Acceptance and Final Payment*.

The Contractor shall deliver to the Owner a complete release of all claims for labor and material arising out of this contract before the final payment is made. If any subcontractor or supplier fails to furnish such a release in full, the Contractor may furnish a bond or other collateral satisfactory to the Owner to indemnify the Owner against any potential lien or other such claim. The bond or collateral shall include all costs, expenses, and attorney fees the Owner may be compelled to pay in discharging any such lien or claim.

90-07 Payment for materials on hand. Partial payments may be made to the extent of the delivered cost of materials to be incorporated in the work, provided that such materials meet the requirements of the contract, plans, and specifications and are delivered to acceptable sites on the airport property or at other sites in the vicinity that are acceptable to the Owner. Such delivered costs of stored or stockpiled materials may be included in the next partial payment after the following conditions are met:

a. The material has been stored or stockpiled in a manner acceptable to the RPR at or on an approved site.

b. The Contractor has furnished the RPR with acceptable evidence of the quantity and quality of such stored or stockpiled materials.

c. The Contractor has furnished the RPR with satisfactory evidence that the material and transportation costs have been paid.

d. The Contractor has furnished the Owner legal title (free of liens or encumbrances of any kind) to the material stored or stockpiled.

e. The Contractor has furnished the Owner evidence that the material stored or stockpiled is insured against loss by damage to or disappearance of such materials at any time prior to use in the work.

It is understood and agreed that the transfer of title and the Owner's payment for such stored or stockpiled materials shall in no way relieve the Contractor of their responsibility for furnishing and placing such materials in accordance with the requirements of the contract, plans, and specifications.

In no case will the amount of partial payments for materials on hand exceed the contract price for such materials or the contract price for the contract item in which the material is intended to be used.

No partial payment will be made for stored or stockpiled living or perishable plant materials.

The Contractor shall bear all costs associated with the partial payment of stored or stockpiled materials in accordance with the provisions of this paragraph.

90-08 Payment of withheld funds. At the Contractor's option, if an Owner withholds retainage in accordance with the methods described in paragraph 90-06 *Partial Payments*, the Contractor may request that the Owner deposit the retainage into an escrow account. The Owner's deposit of retainage into an escrow account is subject to the following conditions:

a. The Contractor shall bear all expenses of establishing and maintaining an escrow account and escrow agreement acceptable to the Owner.

b. The Contractor shall deposit to and maintain in such escrow only those securities or bank certificates of deposit as are acceptable to the Owner and having a value not less than the retainage that would otherwise be withheld from partial payment.

c. The Contractor shall enter into an escrow agreement satisfactory to the Owner.

d. The Contractor shall obtain the written consent of the surety to such agreement.

90-09 Acceptance and final payment. When the contract work has been accepted in accordance with the requirements of Section 50, paragraph 50-15, *Final Acceptance*, the RPR will prepare the final estimate of the items of work actually performed. The Contractor shall approve the RPR's final estimate or advise the RPR of the Contractor's objections to the final estimate which are based on disputes in measurements or computations of the final quantities to be paid under the contract as amended by change order or supplemental agreement. The Contractor and the RPR shall resolve all disputes (if any) in the measurement and computation of final quantities to be paid within 30 calendar days of the Contractor's receipt of the RPR's final estimate. If, after such 30-day period, a dispute still exists, the Contractor may approve the RPR's estimate under protest of the quantities in dispute, and such disputed quantities shall be considered by the Owner as a claim in accordance with Section 50, paragraph 50-16, *Claims for Adjustment and Disputes*.

After the Contractor has approved, or approved under protest, the RPR's final estimate, and after the RPR's receipt of the project closeout documentation required in paragraph 90-11, *Contractor Final Project Documentation*, final payment will be processed based on the entire sum, or the undisputed sum in case of approval under protest, determined to be due the Contractor less all previous payments and all amounts to be deducted under the provisions of the contract. All prior partial estimates and payments shall be subject to correction in the final estimate and payment.

If the Contractor has filed a claim for additional compensation under the provisions of Section 50, paragraph 50-16, *Claims for Adjustments and Disputes*, or under the provisions of this paragraph, such claims will be considered by the Owner in accordance with local laws or ordinances. Upon final adjudication of such claims, any additional payment determined to be due the Contractor will be paid pursuant to a supplemental final estimate.

90-10 Construction warranty.

a. In addition to any other warranties in this contract, the Contractor warrants that work performed under this contract conforms to the contract requirements and is free of any defect in equipment, material, workmanship, or design furnished, or performed by the Contractor or any subcontractor or supplier at any tier.

b. This warranty shall continue for a period of one year from the date of final acceptance of the work, except as noted. If the Owner takes possession of any part of the work before final acceptance, this warranty shall continue for a period of one year from the date the Owner takes possession. However, this will not relieve the Contractor from corrective items required by the final acceptance of the project work. Light Emitting Diode emitting diode (LED) light fixtures with the exception of obstruction lighting, must be warranted by the manufacturer for a minimum of four (4) years after date of installation inclusive of all electronics.

c. The Contractor shall remedy at the Contractor's expense any failure to conform, or any defect. In addition, the Contractor shall remedy at the Contractor's expense any damage to Owner real or personal property, when that damage is the result of the Contractor's failure to conform to contract requirements; or any defect of equipment, material, workmanship, or design furnished by the Contractor.

d. The Contractor shall restore any work damaged in fulfilling the terms and conditions of this clause. The Contractor's warranty with respect to work repaired or replaced will run for one year from the date of repair or replacement.

e. The Owner will notify the Contractor, in writing, within [seven (7)] days after the discovery of any failure, defect, or damage.

f. If the Contractor fails to remedy any failure, defect, or damage within [14] days after receipt of notice, the Owner shall have the right to replace, repair, or otherwise remedy the failure, defect, or damage at the Contractor's expense.

g. With respect to all warranties, express or implied, from subcontractors, manufacturers, or suppliers for work performed and materials furnished under this contract, the Contractor shall: (1) Obtain all warranties that would be given in normal commercial practice; (2) Require all warranties to be executed, in writing, for the benefit of the Owner, as directed by the Owner, and (3) Enforce all warranties for the benefit of the Owner.

h. This warranty shall not limit the Owner's rights with respect to latent defects, gross mistakes, or fraud.

90-11 Contractor Final Project Documentation. Approval of final payment to the Contractor is contingent upon completion and submittal of the items listed below. The final payment will not be approved until the RPR approves the Contractor's final submittal. The Contractor shall:

a. Provide two (2) copies of all manufacturers warranties specified for materials, equipment, and installations.

b. Provide weekly payroll records (not previously received) from the general Contractor and all subcontractors.

c. Complete final cleanup in accordance with Section 40, paragraph 40-08, *Final Cleanup*.

d. Complete all punch list items identified during the Final Inspection.

e. Provide complete release of all claims for labor and material arising out of the Contract.

f. Provide a certified statement signed by the subcontractors, indicating actual amounts paid to the Disadvantaged Business Enterprise (DBE) subcontractors and/or suppliers associated with the project.

g. When applicable per state requirements, return copies of sales tax completion forms.

h. Manufacturer's certifications for all items incorporated in the work.

i. All required record drawings, as-built drawings or as-constructed drawings.

j. Project Operation and Maintenance (O&M) Manual(s).

k. Security for Construction Warranty.

l. Equipment commissioning documentation submitted, if required.

END OF SECTION 90

TECHNICAL PROVISIONS

TECHNICAL PROVISIONS

SECTION 1 - GENERAL

1.1. WORK UNDER THIS CONTRACT

The Contract work shall provide for the design and construction of a 40'X50' Snow Removal Equipment (SRE) Building and new concrete apron. The building shall be a pre-engineered (timber pole frame) building with a one piece hydraulic door. The building shall be designed and constructed in accordance with the criteria, drawings, information and other data provided in these documents. The building will be used to maintain and store snow removal equipment. The occupancy classification for SRE Building shall be Group S-1 in accordance with International Building Code. **Material furnished and installed necessary for the completion of any of the work identified, which is not listed, noted or otherwise included, shall be considered incidental and required for the final approval of the work.**

1.2. ARCHITECTURAL AND PERMIT SERVICES

The Contractor must employ an Architect or Engineer to prepare all necessary contract design calculations, documents and working drawings and obtain all state and local building permits pertaining to the work. The Contractor is responsible for the preparation of documents, drawings and specifications for the design and construction of the pre-engineered timber post building. The site and apron design has been conceptually provided in these plans and specifications. Any information required for the final design of the pre-engineered timber post building is the responsibility of the contractor and its design engineer/architect. The Contractor's Architect/Engineer shall certify to the conformance with the data provided and all pertinent Local, State and Federal statutes, codes, regulations, ordinances, and all other generally accepted professional and industry standards, specifications and guidelines in the development of a pre-engineered timber post building. The entire facility shall be ADA compliant. The design shall include investigating the need for smoke and fire safety devices, such as but not limited to, smoke and carbon monoxide detectors, alarms, sprinkler system and fire extinguishers.

SECTION 2 - SITEWORK

2.1 CONSTRUCTION SURVEY

Contractor shall layout all areas of construction in conformance with the project drawings.

2.2 DEMOLITION – Not Applicable

2.3 UNCLASSIFIED EXCAVATION AND EMBANKMENT

Contractor is responsible for all grading and excavation necessary to construct the building and necessary incidentals. All areas that shall receive fill shall be accurately graded to the appropriate level, and shall be firmly compacted in accordance with quality standards. Excavation will be paid for as a lump sum item.

2.3.1 PAVEMENT SUBGRADES

The Itemized Proposal is separated into General Site Work, which includes the grading outside building limits and concrete apron construction, and Building, which includes all items inside the building limits. All excavation outside of the building will be paid for under the unit price for Unclassified Excavation. All excavation required inside the building limits will be included in the General Construction Work under the building section, which includes, but is not limited to, the floor slab, foundations, building erection, and excavation for the building.

All areas that shall receive floor fill or paving shall be accurately graded to the appropriate subgrade level, and shall be firmly compacted in accordance with quality standards.

2.3.2 FOOTINGS AND FOUNDATIONS

Contractor shall provide excavation to firm bearing soil for all footings and foundations. The contractor is required to design the foundation based on the building loads provided by the pre-engineered building that is to be supplied. The contractor is responsible for providing an engineered set of foundation drawings to be submitted to the owner for review. The contractor is responsible to receive their own Indiana State Design release for the foundation design.

The foundation is considered to be inside the building limits and will be included in the General Construction Work pay item under the Building section, which includes, but is not limited to, the floor slab, foundations, building erection, and excavation for the building.

2.3.3 UTILITIES

The building to be constructed shall be serviced with electricity and provide a ¾" stub out for future propane hookup. It is the Contractors responsibility to coordinate with the electric company, Richmond Power & Lighting, contact information provided in plans. Additional information has been provided by RP&L for service hookup, see SPECIAL PROVISIONS. The Contractor is responsible to provide the MEP units and connections inside the building and allow for service connections to be made. The floor drains will be considered a separate item and paid for under B6.

2.3.4 FINISH GRADING

The finish grade is expected to be at least three inches of top soil, smooth rolled, with no aggregate greater than one inch, and ready for hydro seeding.

2.3.5 SEEDING AND LANDSCAPING

Seeding shall be by Contractor. Landscaping shall be by Owner. The seeding is to be a hydro-seed mulch application of INDOT Type R.

SECTION 3 – Not Applicable

SECTION 4 – Not Applicable

SECTION 5 - CONCRETE WORK

5.1 QUALITY STANDARDS

All concrete used in this project shall be Portland Type I or 1L ready-mix concrete of certified mixed design. Reinforcing steel shall conform to A.S.T.M. A615, Grade 60. The design and placement of all concrete work shall be in accordance with the standards of the American Concrete Institute and the Concrete Reinforcing Steel Institute. Concrete used for footings, foundations, walks and pedestrian door stoops and aprons shall have a 28 day minimum compressive strength of 4000 psi. Concrete used for the floor slab and the hydraulic door foundation shall have a 28 day minimum compressive strength of 5000 psi. All exterior flatwork concrete shall have a minimum of 6% air entrainment. All interior concrete flatwork and reinforced panels on the apron shall be reinforced with welded wire fabric. All other concrete shall be reinforced in accordance with the requirements established during the design of the building.

5.2 FOOTINGS AND FOUNDATIONS

Foundations shall be designed in accordance with structural loads and the Indiana State Building Code, and shall be placed to a minimum depth of 36" below finish grade.

5.2.1 BUILDING FOUNDATION WALL

Foundation wall shall be a minimum of 10" wide with two No. 4 rebars continuous. The foundation must be designed to suit the actual building loads for the building supplied by the contractor. The foundation Design Release is the responsibility of the contractor prior to construction. The foundation is required to have a perimeter frost wall with a minimum of 2" foam board insulation on the interior of the frost wall.

5.2.2 ELECTRIC HYDRAULIC DOOR FOUNDATION

A separate independent foundation shall be provided for the electric hydraulic door in accordance with the door manufacturer's requirements and local building conditions. Foundations must be sized for the actual door that is to be used for the building.

5.2.3 COLUMN PIERS AND FOOTINGS

Column piers and footings shall be designed by the Contractor and certified by a Professional Engineer registered in the State of Indiana. The tops of column piers are to be at finished floor line.

5.3 FLATWORK

5.3.1 INTERIOR FLOOR

5.3.1.1 Building Floor

The SRE building floor shall be 6" thick over 6 inches of granular subbase over compacted subgrade, in accordance with the plans. The floor slab shall be placed and screeded to true lines and grades, and float and trowel to a uniform surface. Expansion joints, 1/2" minimum, shall be provided in accordance with American Concrete Institute Standards specifically at junction with overhead door foundation, exterior approach aprons and building foundation. All joints shall be prepared and sealed with a silicone based joint sealant.

All interior concrete flatwork shall be sealed with a curing and hardening compound. A 4-mil thick polyethylene vapor barrier beneath all interior floor slabs shall be installed. The floor slabs are required to have a minimum of 2" foam board insulation.

5.3.2 SNOW REMOVAL EQUIPMENT BUILDING APRON

The aircraft apron concrete shall be 6 inches thick (Federal Aviation Admission (FAA) P-501 or Indiana Department of Transportation (INDOT) 502) over 6 inches of granular subbase (FAA P-209 or INDOT #53) over compacted subgrade. The concrete shall be broom finished and cured with a high-quality curing compound. Concrete joints, shall be provided in

accordance with details found in the plans. All joints shall be prepared and sealed with silicone sealant installed in accordance with the sealant manufacturer.

5.3.3 OVERHEAD GARAGE DOOR

A 6 inch concrete approach apron of sufficient length with the ends turned down a sufficient depth to resist frost movement. Expansion joints, 1/2" minimum, shall be provided in accordance with American Concrete Institute Standards. All joints shall be prepared and sealed with silicone sealant installed in accordance with the sealant manufacturer.

5.3.4 PEDESTRIAN ENTRANCE DOORS

An exterior stoop at each pedestrian door shall be constructed according to the drawings. Concrete stoops shall be 6" thick, 4000 psi concrete. Expansion joints, 1/2" minimum, shall be provided in accordance with American Concrete Institute Standards. All joints shall be prepared and sealed with silicone sealant installed in accordance with the sealant manufacturer.

SECTION 6

(This section was left blank intentionally)

SECTION 7 – NOT USED

SECTION 8 - INSULATION

8.1 PERFORMANCE STANDARDS

The insulation and weather seal of the building envelope shall be designed and erected in accordance with the "Indiana Energy Conservation Rules and Regulations for New Building Construction" as approved by the Indiana Department of Fire and Building Services.

8.2 QUALITY STANDARDS

Where specified WMP10 (white, reinforced, vinyl) faced insulation shall be installed in continuous lengths across the building, and side edges shall be carefully lapped and stapled to insure a continuous vapor barrier. The facing on all insulation shall carry a UL-25 flame spread rating as certified by Underwriters Laboratories.

Fiberglass insulation facings shall be laminated on one side with the facing as shown in chart below:

FACING	WMP-10
Color	White
Flame Spread*	25
Perm Rating	1.3
Surface Temp. Min.	0 F

*NOTE: The numerical flame spread rating is not intended to reflect hazards presented by this or any other material under actual fire conditions.

Rigid Foam Thermal Blocks are cut from high density extruded polystyrene board stock, having an UL-25 flame spread rating.

8.3 ROOF INSULATION

Provide and install 6" thick WMP10 faced, 0.6# density glass fiber insulation beneath the entire metal roof R=19. Refer to plans for additional information.

8.4 WALL INSULATION

Provide and install 6" thick WMP10 faced, 0.6# density glass fiber insulation behind all exterior metals walls R=19.

8.5 PERIMETER INSULATION

Provide and install 2" thick x (Depth of frost wall) deep rigid polystyrene insulation along the foundation perimeter.

8.6 PARTITION INSULATION

Not Applicable

8.7 MASONRY INSULATION

Not Applicable

SECTION 9 – DOORS AND WINDOWS

9.1 QUALITY STANDARDS

Provide and install doors and frames as called for in the schedules. Doors shall be installed in accordance with the manufacturer's instructions and shall be plumb, anchored, and wedged to operate smoothly without binding.

9.2 STEEL DOORS AND FRAMES

Door leaves shall be 1-3/4" thick with minimum 18 gauge painted steel face sheets, reinforced for all hardware and insulated with a Kraft honeycomb core or approved equal. Frames shall be 16 gauge painted steel, with mitered corners and reinforced for all hardware. Hinges shall be 4-1/2 x 4-1/2" full mortise ball bearing action primed steel, 1-1/2 pair per door leaf. All exterior doors shall be fully weather stripped and shall be supplied with thresholds and closures. All doors and frames shall carry a U.L. approved label. Exterior doors shall be pre-cut for Best Lock Sets or approved equal. All doors shall utilize the same key.

9.3 OVERHEAD DOORS

Not Used

9.4 ONE PIECE HYDRAULIC DOOR

Provide an electrical horizontal one piece hydraulic door that conforms to the following criteria:

- A. The manufacture shall be Higher Power Hydraulic Doors, Inc., 1400 Territorial Rd Benton Harbor, MI 49022 269-927-8990 Fax 269-927-1400.
- B. Clear Width; Per Plans
- C. Clear height: Per Plans
- D. Drive system: Hydraulic Drive
- E. Lift Type: 2 hydraulic rams, one on each side
- F. Truss: external
- G. Power Requirements: per manufacturers recommendation
- H. Latches: Auto Locking/self latching
- I. Limit switches: Automatic stop and start sensors.

- J. Door shall be designed to the same loading requirements for live, dead and wind loads as the SRE building.
- K. Door shall be engineered to resist all anticipated loads without sagging, bowing or conflicting with its smooth and efficient operation.
- L. Design shall be furnished, approved and sealed by a professional engineer registered in the state where the project is located
- M. Building header shall be designed to accommodate horizontal and vertical building deflections to support the door in all positions (with the proper lateral bracing).
- N. Building's door columns shall be framed of the proper design and size to reinforce the opening (with lateral bracing) and to carry all loads and vibrations imposed thereon.
- O. Door should have solid footing with sill directly underneath the door frame and extending outward from the door to provide a base for the door's weather seal. This also prevents flow of water into, or under, the door installation.
- P. The finished floor of the building should be designed to prevent flow of water under the door installation. Sills shall have a slight slope outward of the overhead door to prevent water flow under the door installation
- Q. The door shall be insulated.

9.5 ALUMINUM FRAMED WINDOWS

(This section was left blank intentionally)

SECTION 10

(This section was left blank intentionally)

SECTION 11 - PLUMBING

11.1 PERFORMANCE STANDARDS

Design and install all plumbing items per the International Plumbing Code and all other applicable Federal, State and Local codes. The contractor is to complete the plumbing design based on the selected equipment or approved equals. Like substitutions are allowable. The floor slab will be required to be cut to install drains to the future sewer. Shop drawings, colors and materials are to be submitted to the owner for selection. At a minimum the contractor shall supply and install the following:

1. Floor drains to be capped for future use.
2. All necessary piping, grounding, venting, and incidentals for a functional system.

11.2 EXTERIOR

See section for 2.3.3 UTILITIES for utility connections

SECTION 12 – HEATING AND VENTILATION

12.1 PERFORMANCE STANDARDS

The design and assembly of the building heating and ventilating systems shall be in full accordance with the "Indiana Energy Conservation Rules and Regulations for New Building Construction" as approved by the Indiana Department of Fire and Building Services.

12.2 QUALITY STANDARDS

The installation of all equipment shall be in accordance with the ASHRAE Guide and Handbook of Fundamentals, as published by the American Society of Heating, Refrigeration and Air Conditioning Engineers.

12.3 HEATING

The contractor shall provide install gas (propane) forced air heaters suspended from the roof structure. This system shall be designed to meet or exceed all applicable energy codes that can maintain the building ambient air at 75 degrees Fahrenheit from October to April.

SECTION 13 - ELECTRICAL

13.1 PERFORMANCE STANDARDS

Design and install all electrical items per the National Electric Code and all other applicable Federal, State and Local codes. The contractor is to complete the electrical design based on the selected equipment or approved equals. Like substitutions are allowable. Shop drawings, colors and materials are to be submitted to the owner for selection. At a minimum the contractor shall supply and install the following:

1. 1 - 200 Amp. Sub-panel or larger pending final load designed by contractor.
2. 12 - overhead LED lights Stingray 6XL Clear 48" lights.
3. 12 - GFI duplex outlets
4. 4 – Exterior wall pack LED lights with photocell controls for low and motion control for the fixture to step up to 100% illumination.
5. 2 minimum - Interior LED Thermoplastic Exit Signs: Lithonia LQM Stencil White, with extra faceplate and color panel, red letter, with Nickel-cadmium battery, or approved equal.
6. Thermostatically controlled forced air heat system
7. Power for hydraulic door operator
8. All necessary wiring, grounding, conduit, and incidentals for a functional system.

13.2 SIGNAL

No telephone line shall be provided to the building.

13.3 POWER

Shall be in accordance with the plans.

SECTION 14

(This section was left blank intentionally)

SECTION 15 – PRE-ENGINEERED TIMBER POST FRAME BUILDING

15.1 MANUFACTURER

The timber post frame building shall be a Clear Span type building, as designed, fabricated and supplied by a manufacturer who:

15.1.1 EXPERIENCE

Has at least five years experience as a timber post frame building fabricator.

15.2 DRAWINGS

15.2.1 BUILDING DIMENSIONS

The building dimensions shall be as described in the plans and specifications.

15.2.2 DRAWINGS

The manufacturer shall furnish complete erection drawings for the proper identification and assembly of all building components.

15.2.3 CERTIFICATIONS

Standard drawings and design analysis shall bear the seal of a registered professional engineer upon request.

15.3 STRUCTURAL TIMBER DESIGN

15.3.1 STANDARDS

The Contractor shall be responsible for following all applicable Federal, State, and local building codes, ordinances, or regulations covering the work. The building manufacturer shall use standards, specifications, recommendations, findings and/or interpretations of professionally recognized groups such as AITC, AWC, APA, AAMA, AWI, and AWC National Design Specifications for Wood Construction as the basis for establishing design, drafting, fabrication, and quality criteria, practices, and tolerances. For convenience, one or more sources may be referenced in a particular portion of these specifications. In all instances, however, the manufacturer's design, drafting, fabrication and quality criteria, practices, and tolerances shall govern, unless specifically countermanded by the contract documents or these specifications.

At a minimum the timber post frame building shall include the following:

1. 50ft. x 40ft. timber post frame building consisting of 6x6 posts, 8ft. on center and 2x4 wall purlins and roof purlins 2ft. on center.
2. Roof pitch to be 3/12 consisting of trusses 4ft. on center.
3. The timber frame shall not extend below grade but placed on concrete columns.

15.4 DESIGN LOADS

Compliance will be met by adhering to the Indiana Building Code most recent edition, and the International Building Code (IBC) most recent addition.

State, county, local, or other jurisdictional building ordinances adopting and enforcing the model codes, listed above, in their entirety, without significant revisions or changes in the direction of less seismic safety, shall also meet the requirements. If the design loads allowed by these standards are less than the following, the following loads will apply. Live load 25 psf. Wind load 80 mph. Dead load will be actual load of the structure plus snow load.

15.5 BASIC MATERIAL SPECIFICATIONS

At a minimum the timber post frame building shall include the following:

1. 50ft. x 40ft. timber post frame building consisting of 6x6 posts, 8ft. on center and 2x4 wall purlins and roof purlins 2ft. on center.

15.5.1 ROOF AND WALL PANEL MATERIAL:

Wall panel material as specified shall be 26 gauge (.019 ordered minimum thickness) and the roof panel material as specified shall be 24 gauge (.023 ordered minimum thickness) galvalume® type, conforming to the requirements of ASTM A446 Grade E or Grade D. Minimum yield stress shall be 80 000 psi for Grade E and 50,000 psi for Grade D.

15.6 ROOFING AND WALL COVERING

15.6.1 STANDING SEAM ROOF

Standing seam roof shall be 24-gauge (.023 ordered minimum thickness) Grade "D" Galvalume steel. Roof may be factory coated white or galvalume gray.

15.6.2 PANEL COVERAGE

Panel coverage will be 24". Major ribs will be on 24" centers with ribs being a minimum depth of 3" below the Standing Seam interlock. Panel flat will have minor ribs to minimize waviness.

15.6.3 CONNECTION TO PURLINS

Connection to purlins will be with an articulating clip that allows for expansion and contraction as well as compensating for any non-parallelism on the part of the purlin flange. Clip base shall be 16-gauge minimum thickness.

15.6.4 EAVE FASTENERS

All eave fasteners shall be through a plate extending from the eave strut so that through fasteners are outside the building envelope. All sheet butt laps shall be made with back-up plates and lap straps, off the purlin. Peak connection will allow for expansion. Panels will be pre-punched.

15.6.5 SIDELAP OF THE STANDING SEAM

Side lap of the Standing Seam will be field roll formed in a double fold to form a Pittsburgh lockseam. Panel mastic will be shop applied. Simple interlocking sidelap or batten panels will not be accepted.

15.6.6 INTERIOR LINER PANELS

Interior liner panels shall be placed on all interior walls of the building. The panels shall be 26 gauge white painted metal and extend from finished floor to ceiling.

15.7 MISCELLANEOUS MATERIAL SPECIFICATIONS

15.7.1 FASTENERS FOR ROOF PANELS

All panels shall be attached to the secondary framing members by means of self-drilling structural screws for roofs shall be carbon steel No. 12-14 x 1" Hex washer head, cadmium or zinc plated, with or without painted head, assembled with EPDM washer. These fasteners are applicable for use with fiberglass blanket insulation from 0" to 6" thick. All self-drilling sidelap screws are #14 x 7/8 with washer, regardless of structural screw length or metal type. **Thermal blocks to keep the specified 6 inch fiberglass blanket insulation from being compressed will be used.**

15.7.2 FASTENERS FOR WALL PANELS

All "A" panels shall be attached to the secondary-framing members by means of self-drilling fasteners of stainless steel #12 x 1¼" with washers for fiberglass insulation 3" to 6" thick.

15.7.3 FASTENERS FOR WALL PANEL SIDELAPS

Self-drilling *12 x 7/8 stainless steel screws with washers.

15.7.4 BLIND FASTENERS

All blind fasteners shall be 1/8" diameter, high strength aluminum pull rivet Type ADH.

15.7.5 SEALANTS AND CLOSURES

15.7.5.1 CLOSURE STRIPS

The corrugations of the roof and wall panels shall be filled with solid or closed-cell, preformed rubber, neoprene or polyethylene closures along the eave, ridge and rake for weather tightness.

15.7.5.2 STANDING SEAM SEALANT

See Section 15.6.

15.7.5.3 CAULK

All gutter and downspout, rake flashing laps, ridge flashing laps, doors, windows, and louvers shall be sealed with white or burnished slate pigmented caulk or butyl rubber base.

15.7.6 GUTTER, FLASHING AND DOWNSPOUTS

15.7.6.1 GUTTERS AND FLASHING

All standard exterior gutters are 26 gauge galvalume steel, with painted finish in white or burnished slate. Standard rake flashing is 26 gauge galvalume steel, painted finish in white or burnished slate. In no case shall flashing be less than 26 gauge steel. Bottom of wall panels shall have sill flashing.

15.7.6.2 DOWNSPOUTS

All downspouts shall be 26 gauge galvalume steel with color coordinated finish, rectangular in shape.

15.8 PAINTING

15.8.1 PAINTED STEEL PANELS

15.8.1.1 BASE METAL

Base metal shall be 26 gauge galvalume steel (ordered thickness .019 minimum).

15.8.1.2 PRIME COAT

The base metal shall be pre-treated and then primed with an epoxy type primer for superior adhesion and superior resistance to corrosion.

15.8.1.3 EXTERIOR COAT

15.8.1.3.1 SALT SPRAY RESISTANCE

Immediately after removal from cabinet, the coating shall receive a rating of 8, few pinpoint or #8 sized blisters, as determined by ASTM D714 and a rating of 10 1/16 inch failure at scribe as determined by ASTM D1654, when tested for a minimum of 1000 hours in accordance with ASTM B117.

15.8.1.3.2 ABRASION RESISTANCE

When subjected to the falling sand test in accordance with ASTM D968, the coating system shall withstand a minimum of 30 liters of sand before the appearance of base metal. The Taber Wear Factor shall be 100.0 or less when tested for 250 cycles on the Taber CS-10 Calibrase Wheel, 500 gram load.

15.8.1.3.3 HARDNESS

The paint film shall have a minimum paint hardness of F-2H using "Eagle Turquoise" drawing pencils.

15.8.1.3.4 GLOSS

The gloss reading shall be 20-35 units on a 60* Gardner gloss - meter for pleasing appearance and reflectivity.

15.8.1.3.5 IMPACT RESISTANCE

Factory painted sheet shall withstand direct and reverse impact in accordance with ASTM D2794 equal to 1.5 times metal thickness in mils, expressed in inch-pounds, with no loss of adhesion.

15.8.1.3.6 PAINTED PANEL WARRANTY

Vertical panels shall be conditionally guaranteed for 10 years. Horizontal panels shall be conditionally guaranteed for 5 years

15.8.1.3.7 COLOR

Exterior paint color to be selected by Sponsor from manufacturer's standard color charts. It is expected to be tan with white trim.

15.8.1.4 INTERIOR FINISH

The interior liner panel is to be 26 gauge painted metal,, to full height of overhead door (14'). The finish shall be a white or parchment top coat over epoxy primer or an epoxy base coat, white or parchment, with a clear polyester top coat. All red iron in the building is to be painted white or gray.

15.9 ERECTION AND INSTALLATION

The erection of the timber post frame building and the installation of accessories shall be performed in accordance with erection drawings by a qualified erector using proper tools and equipment. There shall be no field modifications to primary structural members except as authorized and specified by the manufacturer.

15.10 BUILDING ANCHORAGE AND FOUNDATIONS

The timber frame shall not extend below grade but placed on concrete columns.

Foundations shall be adequately designed by a qualified foundation engineer to support the building reactions and other loads which may be imposed by the building use. The design shall be based on the specific soil conditions of the building site. The foundation engineer shall be retained by other than the manufacturer. The manufacturer assumes no responsibility for the integrity of the foundation.

END OF TECHNICAL PROVISIONS

SPECIAL PROVISIONS

INSTRUCTIONS TO BIDDERS.

Add the following in the Disadvantage Business Enterprise subsection:

The DBE goal percentage shall be 5.3%.

All DBE contractors, subcontractors or suppliers must be currently certified by INDOT to count toward the goal.

CONSTRUCTION CONTRACT.

Under Article VI Payment Procedures paragraph 6.1 Partial Payments, the day for the Engineer to receive the Contractor's application for payment is the first Thursday of each month.

FEDERAL PROVISIONS

DAVIS BACON REQUIREMENTS

Under section 3. Payrolls and basic records. The contractor will be required to submit certified payroll in both hard copy and in electronic PDF to the office of ENGINEER and PDF versions only to the OWNER and the ENGINEERS field representative per the regularly scheduled pay period of the successful contractor.

GENERAL PROVISIONS.

10-53 SUBSTANTIAL COMPLETION.

Add the following new definition:

10-66 SUBSTANTIAL COMPLETION. "Substantial Completion" refers to the date when the construction of a structure is sufficiently completed, in accordance with the plans and specifications, as modified by any complete change orders agreed to by the parties, so that it can be used for which it was intended.

20-02 PREQUALIFICATION OF BIDDERS.

Add the following:

Each bidder shall furnish to the owner with his bid executed Form 96 as prescribed by the Indiana State Board of Account accompanied by all other information specified in the "INSTRUCTIONS TO BIDDERS" Section in front of Document.

Any successful Bidder on Municipal, Township, County or State work in the State of Indiana, whose official address and/or place of business is outside the State of Indiana, must register with the Indiana State Department of Revenue and make arrangements for payment of State Gross or Adjusted Gross Income Tax. Satisfactory evidence of the registration must be submitted to the Owner prior to receipt of any progress payment.

20-05 INTERPRETATION OF ESTIMATED PROPOSAL QUANTITIES.

Add the following:

Work necessary for the completion of the project, which is not included as a contract item in the itemized proposal, shall be considered incidental and will not be paid for directly but shall be spread over other contract items.

20-07 PREPARATION OF PROPOSAL.

Replace with the following:

20-07 PREPARATION OF PROPOSAL. The bidder shall submit his/her proposal on the forms furnished by the owner. All blank spaces in the proposal forms must be correctly filled in where indicated for each and every item for which a quantity is given. The bidder shall state the price (written in ink or typed) for which he proposes to do each pay item furnished in the proposal.

The bidder shall sign his/her proposal correctly and in ink. If the proposal is made by an individual, his/her name and post office address must be shown. If made by a partnership, the name and post office address of each member of the partnership must be shown. If made by a corporation, the person signing the proposal shall give the name of the state under the laws of which the corporation was chartered and the name, titles, and business address of the president, secretary, and the treasurer. Anyone signing a proposal as an agent shall file evidence of his/her authority to do so and that the signature is binding upon the firm or corporation.

Attention of the Bidders is called to the fact that governmental units are exempt from the Indiana Gross Tax (i.e., sales and use tax). All materials incorporated as a material or integral part of construction work for the State, County, Township, Municipality, its agencies and instrumentalities are exempt from this tax. The authorized person will furnish upon request to the successful Bidder any needed information for purposes of filling out the Exemption Certificate form.

Owner is also exempt from Federal Excise Tax. The federal register number will be furnished to the successful Bidder upon request.

40-02 ALTERATION OF WORK AND QUANTITIES.

Replace with the following:

40-02 ALTERATION OF WORK AND QUANTITIES. The owner reserves and shall have the right to make such alterations in the work as may be necessary or desirable to complete the work originally intended in an acceptable manner. No change order shall be issued, which, in the aggregate, would exceed 20 percent of the original amount set forth in the Contract. Alterations which do not exceed the 20 percent limitation shall not invalidate the contract nor release the surety, and the Contractor agrees to accept payment for such alterations as if the altered work had been a part of the original contract. These alterations which are for work within the general scope of the contract shall be covered by "Change

Orders" issued by the engineer. Change orders for altered work shall include extensions of contract time where, in the Engineer's opinion, such extensions are commensurate with the amount and difficulty of added work.

50-03 COORDINATION OF CONTRACT, PLANS, AND SPECIFICATIONS.

Add the following:

Shop drawings shall govern all details of the work taking precedence over all other drawings.

50-04 COOPERATION OF CONTRACTOR.

Add the following:

The Contractor shall be responsible for keeping a legible and accurate field set of "Record" drawings. These drawings shall be submitted to the Engineer upon completion of the project.

50-12 MAINTENANCE DURING CONSTRUCTION.

Add the following:

The Contractor shall supply all temporary heat and light at his own expense for such periods of time and to maintain such temperature or light as is required for the proper protection and execution of the work.

60-01 SOURCE OF SUPPLY AND QUALITY REQUIREMENTS.

Add the following:

The Contractor shall furnish airport lighting equipment that conforms to the requirements of cited materials specifications. In addition, where an FAA specification for airport lighting equipment is cited in the plans or specifications, the Contractor shall furnish such equipment that is:

a. Listed in FAA Advisory Circular (AC) 150/5345-53, Airport Lighting Equipment Certification Program, that is in effect on the date of advertisement; and,

b. Produced by the manufacturer qualified (by FAA) to produce such specified and listed equipment. The airport lighting equipment required for this contract is to be furnished by the contractor in accordance with the requirements of this subsection, and as listed on the plans, specifications and/or in the special provisions. All lighting equipment shall be stamped or tagged with the appropriate FAA identification number.

The Contractor shall, at his own expense, prior to the manufacture or fabrication of any materials which he is to furnish and which are not built from detailed designs shown in the contract documents, submit for the approval of the Engineer, three (3) complete sets of

detailed drawings of such material. These drawings shall be accurate and distinct and shall give all working dimensions, kinds of material to be used, kinds of machine work, finish to be applied and all like information. One (1) set of drawings furnished by the Contractor will be returned after approval by the Engineer. If required by the Engineer, the drawings shall be revised and three (3) sets of revised drawings shall be furnished until the approval of the Engineer has been obtained. The approval of the submitted drawings shall not be interpreted in any way to classify any particular work for payment.

If shop drawings show variations from the work required by the contract, because of standard shop practice or other similar reasons, the Contractor shall make specific mention of such variation in his letter of transmittal in order that, if acceptable, suitable action may be taken by the engineer for proper price adjustment; otherwise, the Contractor will not be relieved of his responsibility for executing the work in accordance with the contract even though such shop drawings are approved by the Engineer.

The approval of such drawings by the Engineer relate only to the requirements for strength and detail and such approval will not relieve the contractor from responsibility for errors, or responsibility for the adequacy or safety or falsework, cofferdams, or other temporary work. Authorized alterations will be endorsed on approval plans or shown on supplementary sheets. Any work done or material ordered prior to the approval of such plans and drawings shall be at the Contractor's risk.

When detailed plans are required, they shall be submitted to the Engineer for approval. They shall be signed by and bear the seal of a Registered Professional Engineer.

Only shop drawings officially stamped as approved by the Engineer will be permitted for use during construction.

60-06 STORAGE OF MATERIALS.

Add the following:

No shanties, garages, buildings for storage of materials, or any other purpose shall be erected on land owned or leased by the Owner, unless a permit in writing is secured from the owner, allowing their construction. Should permission be asked and granted, the Contractor must comply with all local regulations regarding the construction and maintenance of such buildings.

Shipments of materials to be used by the Contractor or any subcontractor shall be delivered to the job site only during regular working hours. All shipments and shipping papers shall be addressed and consigned to the Contractor. Under no circumstances shall shipments be delivered to or in care of the owner or his representatives.

The Owner shall not be responsible for the loss of, or the security of, the materials, tools or equipment of the Contractor or subcontractors.

70-02 PERMITS, LICENSES, AND TAXES.

Add the following:

The Contractor will be required to furnish a certificate from the Indiana State Industrial Board as evidence that he has complied with the provisions of the "Indiana Workmen's Compensation Act", and also the "Indiana Workmen's Occupational Diseases Act", Chapter 69 of the Acts of the Indiana General Assembly, 1937.

If the Contractor is a foreign (out of State) corporation, he shall be required to furnish a certificate from the Secretary of the State of Indiana showing that the corporation is registered and authorized to transact business in the State of Indiana, as required by the Indiana General Corporation Act as stated therein and expressed in the Attorney General's Opinion #2, dated January 13, 1958.

70-06 SANITARY, HEALTH, AND SAFETY PROVISIONS.

Add the following:

The Contractor shall be responsible for all obligations prescribed as employer obligations under Chapter XVII of Title 29, Code of Federal Regulations, Part 1926, otherwise known as "Safety and Health Regulations for Construction."

The Contractor shall also be responsible for all obligations under 29 CFR Part 1926 Occupational Safety and Health Standards, as part of the Contract Documents.

The Contractor shall provide sanitary facilities for employees at the construction areas. No airport facilities will be used.

All employees of the Contractor shall be of a legal age as set out in the Federal, State or local Statutes (whichever is binding). Only those persons associated with the construction of said project will be permitted on the construction site. No under age persons will be allowed on site under any circumstances. The Engineer shall have the authority to ask these persons to leave the site.

70-10 PROTECTION AND RESTORATION OF PROPERTY AND LANDSCAPE.

Add the following:

All debris deposited on any active aircraft operation pavement due to construction activities shall be removed immediately. Methods for removal of large debris such as gravel, dirt clods, concrete pieces, material containers, etc., shall be subject to the approval of the Engineer. Dust control for debris shall be performed with hand tools and self-propelled truck-type vacuum cleaners as approved by the Engineer.

70-19 ENVIRONMENTAL PROTECTION.

Add the following:

To minimize the adverse environmental effects of construction operations, the following restrictions will be placed upon the Contractor's carrying out the work:

- a. All drilling apparatus which may be necessary to carry out the work will be equipped with dust controlling systems.
- b. Minimum areas of land will be exposed for minimum lengths of time reasonably necessary to carry out the construction processes.
- c. Temporary mulch, with or without seeding, will be used on disturbed earth areas.
- d. The use of water sprinkler trucks may be required during certain periods if reasonably necessary to control the amount of dust raised during the earthwork items.
- e. Application rates of herbicides will be restricted to recommended dosages.
- f. Construction materials will be covered when not in use to protect the materials from the natural elements, and to protect the surrounding areas from pollution by escape of the materials.
- g. Application equipment and empty containers will not be rinsed or discharged in a place or manner so as to pollute natural or underground water channels or flows.
- h. Bituminous mixing plants will be equipped with a dust collector, which will waste or uniformly return to the hot elevator, all or any part of the material so collected.
- i. Construction operations may be delayed until climate and wind conditions will reasonably dissipate or inhibit the potential pollutants in a manner satisfactory to the Engineer.
- j. Appropriate gradients will be selected for backslopes and channels and proper provision of berms, drainage features, soil stabilization, pavement, and turf will be made to control or prevent erosion due to wind or water.
- k. Construction of berms, dikes, dams, drains and sediment basins, or use of fiber mats, woven plastic filter cloths, gravel, mulches, quick growing grasses, sod, bituminous spray, and other erosion control devices will be required where necessary to reasonably insure that soil erosion that might cause water pollution is kept to a minimum.
- l. The Contractor will be required to submit to the Engineer for acceptance, schedules for accomplishment of temporary erosion and pollution control work. The Contractor will also be required to submit for acceptance by the Engineer, his proposed method of operation for control of erosion on construction or haul roads and borrow pits, and his plan for disposal of waste materials or erosion control details for other potential sources of pollution.
- m. The Contractor will be required to complete all permanent erosion control features at the earliest practicable time.

- n. Temporary pollution control features and measures will be used to correct unforeseen conditions that occur during construction or those that are needed prior to completion of the permanent measures.
- o. The surface area of erodible earth material to be exposed by clearing and grubbing, excavation, or borrow and fill shall be limited to reasonable areas.
- p. Temporary bridges over surface watercourses will be required wherever crossings would otherwise adversely affect sediment levels and an appreciable number of watercourse crossings are necessary.
- q. All waterways will be promptly cleared by the Contractor of falsework, piling, debris, or other obstructions placed during construction work and not a part of the finished work.
- r. Water from aggregate washing or other operations containing sediment will be treated by filtration, a settling basin or other means sufficient to reduce the sediment content to not more than that of the waterway into which the water will be discharged.
- s. Pollutants, such as fuels, lubricants, bitumens, raw sewage, and other harmful materials will not be discharged into or near surface waterways or into natural or manmade channels leading thereto. Wash water or waste from concrete mixing or curing operations will not be allowed to enter the waterways.
- t. Controls to minimize dust, erosion and sedimentation will be instituted as required by the guidelines set forth in the Federal Aviation Administration Circulars 150/5370-10, "Item P-156 Temporary Air and Water Pollution, Soil Erosion, and Siltation Control", and 150/5370-7 "Airport Construction Controls to Prevent Air and Water Pollution".
- u. Runway closure conditions will be kept to a minimum in an effort to minimize inconvenience to users of the Airport.

The erosion control features installed by the Contractor will be acceptably maintained by the Contractor during the time that construction work is being done. The Owner reserves the right to employ outside assistance to provide necessary corrective pollution control measures in case of repeated failures on the part of the Contractor to do so.

Guidelines as cited in Federal Aviation Administration Circular 150/5370-2, current edition, "Operational Safety on Airports During Construction", will be enforced where applicable. In the event of conflict between these requirements and pollution control laws, State or local agencies, the more restrictive laws, rules or regulations will apply.

80-03 PROSECUTION AND PROGRESS.

Add the following:

Any employee of a Contractor or Subcontractor considered by the Owner to be a risk to public safety and security will be prohibited from entering the security area.

The Contractor shall be responsible for maintaining existing security fencing in the construction area for the duration of the project. All unmanned gates shall be closed and locked.

The Contractor assures that no action by his operation will cause a safety and/or security violation. The Contractor shall be responsible for any penalty fees levied the airport by the FAA due to the construction area not being secured. Any safety and security work as described herein and on the Construction Plans shall be measured and paid for by the contract unit price per month or fraction thereof based on a 30 day month. If safety and security does not have a separate pay item, it shall be considered a necessary incidental to the work and not paid for directly, but included in the cost of other work.

80-05 CHARACTER OF WORKERS, METHODS, AND EQUIPMENT.

Add the following:

Any person employed by the Contractor or by a subcontract or who, in the opinion of the Engineer, does not perform his work in a proper and skillful manner or is intemperate or disorderly shall, at the written request of the Engineer, be removed forthwith by the Contractor or subcontractor employing such person, and shall not be employed again in any portion of the work without the approval of the Engineer. Should the Contractor fail to remove such person or persons or fail to furnish suitable and sufficient personnel for the proper prosecution of the work, the Engineer may suspend the work by written notice until compliance with such orders.

80-08 FAILURE TO COMPLETE ON TIME.

Add the following:

SCHEDULE	LIQUIDATED DAMAGES COST	*ALLOWED CONTRACT TIME
Phase 1	Five Hundred Dollars (\$500.00) per calendar day	Continuous 150 calendar days from date of Notice to Proceed to Substantial Completion
Final Acceptance	Five Hundred Dollars (\$500.00) per calendar day	Continuous 14 calendar days from date of issuance of Punch List

*A separate Notice to Proceed shall be issued for these work activities.

90-05 PAYMENT FOR EXTRA WORK.

Add the following:

When the change order or authorizing the extra work requires that it be done by force account, such force account shall be measured and paid for based on expended labor, equipment, and materials plus a negotiated and agreed upon allowance for overhead and profit.

SUPPLEMENTAL INFORMATION FROM RP&L

The meter base shall be installed by the Contractor and must be acceptable to Richmond Power & Light. See figure below for additional requirements at service points. The contractor shall install 2" conduit from the transformer service point. The Contractor is responsible for sizing and installing cables from the transformer to provide power to the building. All work shall be coordinated with RP&L.

Underground Service, Surface-Mount Meter

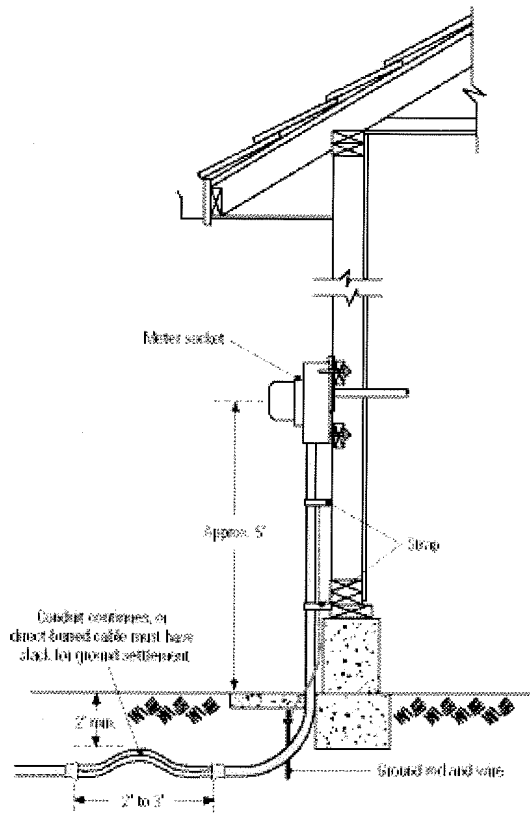

Figure 3-4. Underground service to a surface-mount meter.

Figure 3-4 shows a finished underground installation with the meter on the surface of a house.

The service is underground from the power company to a stubout, handhole, or padmount transformer (off to the left and not shown here). Conductors placed in the trench bring the power to the conduit at the base of the service entrance.

END OF SPECIAL PROVISIONS